

SCIENCE

MINIMUM LEVEL MATERIAL

for

CLASS – X

2018 – 19

Prepared by

M. S. KUMARSWAMY, TGT(MATHS)

M. Sc. Gold Medallist (Elect.), B. Ed.

Kendriya Vidyalaya gachibowli

DEDICATED

TO

MY FATHER

LATE SHRI. M. S. MALLAYYA

**MINIMUM LEVEL DAILY REVISION SYLLABUS
FOR REMEDIAL STUDENTS
SCIENCE : CLASS X**

S. NO.	CHAPTER/TOPIC	MARKS COVERED AS PER LATEST CBSE SAMPLE PAPERS
1	Metals and Non-metals – Full Chapter	5
2	Carbon and its compound – Full Chapter	7
3	Life Process – Full Chapter	6
4	Control and Coordination – Full Chapter	5
5	Our Environment – Full Chapter	5
6	Human Eye – Full Chapter	5
7	Magnetic Effect of Electric Current – Full Chapter	8
Total Marks		41

All Remedial Students have to complete the above chapters/topics thoroughly with 100% perfection and then they can also concentrate the below topics for Board Exam:

*Electricity – **imp questions**

*Light – **imp questions**

*Sources of Energy – **imp questions**

*Heredity and Evolution – **imp questions**

*How do organisms reproduce – **imp questions**

*Acid, Bases and Salts – **imp questions**

.....

INDEX OF MINIMUM LEVEL LEARNING STUDY MATERIAL

CLASS X : SCIENCE

S. NO.	CHAPTER/CONTENT	PAGE NO.
1	Metals and Non metals Important Question and Answers	1 – 16
2	Carbon and its Compounds Important Question and Answers	17 – 31
3	Life Processes Important Question and Answers	32 – 48
4	Control and Coordination Important Question and Answers	49 – 60
5	Our Environment Important Question and Answers	61 – 67
6	Human Eye and Colourful World Important Question and Answers	68 – 79
7	Magnetic Effects of Electric Current Important Question and Answers	80 – 100
8	Electricity Important Question and Answers	101 – 113
9	Light – Reflection and Refraction Important Question and Answers	114 – 130
10	Sources of Energy Important Question and Answers	131 – 136
11	Heredity and Evolution Important Question and Answers	137 – 142
12	How Do Organisms Reproduce Important Question and Answers	143 – 153
13	Acids, Bases and Salts Important Question and Answers	154 – 163

METALS AND NON-METALS

VERY SHORT ANSWER TYPE QUESTIONS [1 MARK]

- 1. A green layer is gradually formed on a copper plate left exposed to air for a week in a bathroom. What could this green substance be?**
Answer. It is due to the formation of basic copper carbonate $[\text{CuCO}_3 \cdot \text{Cu}(\text{OH})_2]$.
- 2. A non-metal X exists in two different forms Y and Z. Y is the hardest natural substance, whereas Z is a good conductor of electricity. Identify X, Y and Z.**
Answer. 'X' is carbon, 'Y' is diamond as it is the hardest natural substance and 'Z' is graphite as it is good conductor of electricity.
- 3. Metals generally occur in solid state. Name and write symbol of a metal that exists in liquid state at room temperature.**
Answer. Mercury(Hg) exists in liquid state at room temperature.
- 4. Which of the following two metals will melt at body temperature (37 °C) ? Gallium, Magnesium, Caesium, Aluminium**
Answer. Gallium and Caesium
- 5. From amongst the metals sodium, calcium, aluminium, copper and magnesium, name the metal (a) which reacts with water only on boiling, and (b) another which does not react even with steam.**
Answer. (a) Magnesium reacts with water only on boiling.
(b) Copper does not react even with steam.
- 6. Which one of the following metals does not react with oxygen even at high temperatures ? (a) Calcium (b) Gold (c) Sodium**
Answer. (b) Gold does not react with oxygen even at high temperatures.
- 7. Name any one metal which reacts neither with cold water nor with hot water, but reacts with heated steam to produce hydrogen gas.**
Answer. Iron; $3\text{Fe}(\text{s}) + 4\text{H}_2\text{O}(\text{g}) \rightarrow \text{Fe}_3\text{O}_4(\text{s}) + 4\text{H}_2(\text{g})$
- 8. Why does calcium float in water?**
Answer. It is because hydrogen gas is formed which sticks to surface of calcium, therefore it floats.
- 9. Name a non-metal which is lustrous and a metal which is non-lustrous.**
Answer. Iodine is a non-metal which is lustrous, lead is a non-lustrous metal.
- 10. Which gas is liberated when a metal reacts with an acid? How will you test the presence of this gas?**
Answer. Hydrogen gas is formed. Bring a burning matchstick near to it, H₂ will burn explosively with 'pop' sound.
- 11. Name the metal which reacts with a very dilute HNO₃ to evolve hydrogen gas.**
Answer. Magnesium
- 12. Name two metals which are found in nature in the free state.**
Answer.(i) Gold (ii) Silver
- 13. What is the valency of silicon with atomic number 14?**
Answer. Its valency is equal to 4.
- 14. What is the valency of phosphorus with atomic number 15?**
Answer. Phosphorus has valency 3.
- 15. What is the valency of an element with atomic number 35?**
Answer. Its valency is 1.
- 16. Arrange the following metals in the decreasing order of reactivity: Na, K, Cu, Ag.**
Answer. $\text{K} > \text{Na} > \text{Cu} > \text{Ag}$
- 17. An element forms an oxide, A₂O₃ which is acidic in nature. Identify A as a metal or non-metal.**
Answer. 'A' is non-metal as non-metallic oxides are acidic in nature.

18. A green layer is gradually formed on a copper plate left exposed to air for a week in a bathroom. What could this green substance be ?

Answer. It is due to the formation of basic copper carbonate $[\text{CuCO}_3 \cdot \text{Cu}(\text{OH})_2]$.

SHORT ANSWER TYPE QUESTIONS[I] [2 MARKS]

19. Write one example of each of

- (i) a metal which is so soft that, it can be cut with knife and a non-metal which is the hardest substance.
- (ii) a metal and a non-metal which exist as liquid at room temperature.

Answer.

- (i) Sodium, carbon (diamond).
- (ii) Mercury is liquid metal, bromine is liquid non-metal.

20. Mention the names of the metals for the following:

- (i) Two metals which are alloyed with iron to make stainless steel.
- (ii) Two metals which are used to make jewellery.

Answer.

- (i) Nickel and chromium.
- (ii) Gold and platinum.

21. Give reason for the following:

- (a) School bells are made up of metals.
- (b) Electric wires are made up of copper.

Answer.

- (a) It is because metals are sonorous, i.e. they produce sound when struck with a hard substance.
- (b) It is because copper is good conductor of electricity.

22. Name the following:

- (a) A metal, which is preserved in kerosene.
- (b) A lustrous coloured non-metal.
- (c) A metal, which can melt while kept on palm.
- (d) A metal, which is a poor conductor of heat.

Answer.

- (a) Sodium is preserved in kerosene.
- (b) Iodine is lustrous coloured non-metal.
- (c) Gallium.
- (d) Lead.

23. Explain why calcium metal after reacting with water starts floating on its * surface. Write the chemical equation for the reaction. Name one more metal that starts floating after some time when immersed in water.

Answer. Calcium starts floating because the bubbles of hydrogen gas formed stick to the surface of metal.

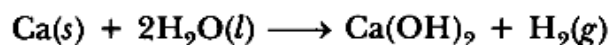

Magnesium reacts with hot water and starts floating due to the bubbles of hydrogen gas sticking to its surface.

24. Give reason for the following:

- (a) Aluminium oxide is considered as an amphoteric oxide.
- (b) Ionic compounds conduct electricity in molten state.

Answer.

- (a) It is because it reacts with acids as well as bases to produce salts and water. 'Al' is less electropositive metal. So, it forms amphoteric oxide which can react with acid as well as base.
- (b) Ionic compounds can conduct electricity in molten state because ions 'become free to move in molten state.

25. Write two differences between calcination and roasting.

Answer.

Calcination	Roasting
(i) It is carried out by heating ore in the absence of air.	(i) It is carried out by heating ore in the presence of air.
(ii) It converts carbonate ores into oxides.	(ii) It converts sulphide ores into oxides.

26. The way, metals like sodium, magnesium and iron react with air and water is an indication of their relative positions in the 'reactivity series'. Is this statement true? Justify your answer with examples.

Answer. Yes, sodium reacts explosively even with cold water, it is most reactive. Magnesium reacts with hot water, it is less reactive than Na. Iron reacts only with steam which shows it is least reactive among the three.

27. $X + YSO_4 \longrightarrow XSO_4 + Y$

$Y + XSO_4 \longrightarrow$ No reaction

Out of the two elements, 'X' and 'Y', which is more reactive and why?

Answer. 'X' is more reactive than 'Y' because it displaces 'Y' from its salt solution.

28. What is an alloy? State the constituents of solder. Which property of solder makes it suitable for welding electrical wires?

Answer. Alloy is a homogeneous mixture of two or more metals. One of them can be a non-metal also. Solder consists of lead and tin. It has low melting point which makes it suitable for welding electrical wires.

29. Using the electronic configurations, explain how magnesium atom combines with oxygen atom to form magnesium oxide by transfer of electrons.

Answer.

$Mg(12) = 2, 8, 2$

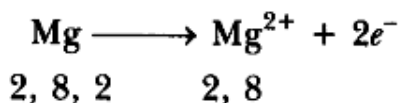

$O(8) = 2, 6$

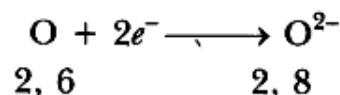

$(Mg)^{2+} (\ddot{O})^{2-}$

30. When a metal X is treated with cold water, it gives a base Y with molecular formula XOH (Molecular mass = 40) and liberates a gas Z which easily catches fire. Identify X, Y and Z.

Answer.

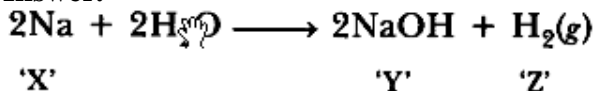

'X' is sodium, 'Y' is sodium hydroxide, 'Z' is $H_2(g)$.

31. (a) Give two methods to prevent the rusting of iron.

(b) Name the ores of the following metals:

(i) mercury, and

(ii) zinc

Answer.

(a)(i) Painting (ii) Galvanisation

(b)(i) Cinnabar (ii) Zinc Blende

32. Write chemical equations that shows aluminium oxide reacts with acid as well as base.

Answer.

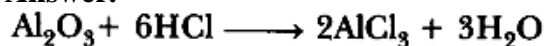

33. Elements magnesium and oxygen respectively belong to group 2 and group 16 of the Modern Periodic Table. If the atomic numbers of magnesium and oxygen are 12 and 8 respectively, draw their electronic configurations and show the process of formation of their compound by transfer of electrons.

Answer.

Mg(12)=2,8,2

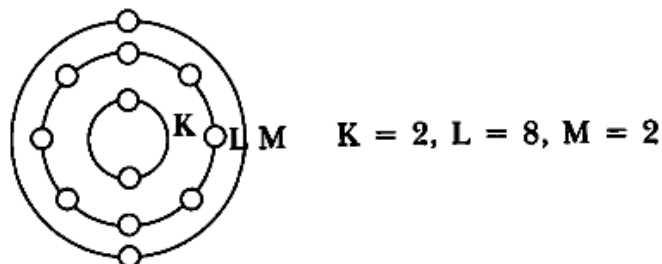

O(8) = 2, 6

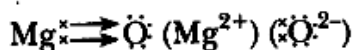
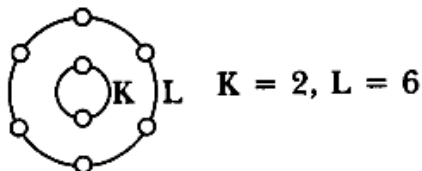

SHORT ANSWER TYPE QUESTIONS[II] [3 MARKS]

34. State three reasons for the following facts

(i) Sulphur is a non-metal

(ii) Magnesium is a metal

One of the reasons must be supported with a chemical equation.

Answer.

Sulphur is a non-metal	Magnesium is a metal
(i) Poor conductor of heat and electricity	(i) Good conductor of heat and electricity
(ii) Neither malleable nor ductile	(ii) Malleable nor ductile
(iii) $\text{S} + \text{O}_2 \rightarrow \text{SO}_2$ $\text{SO}_2 + \text{H}_2\text{O} \rightarrow \text{H}_2\text{SO}_3$ (Sulphurous acid) Sulphur dioxide is acidic oxide.	(iii) $2\text{Mg} + \text{O}_2 \rightarrow 2\text{MgO}$ $\text{MgO} + \text{H}_2\text{O} \rightarrow \text{Mg}(\text{OH})_2$ (Magnesium hydroxide) Magnesium oxide is basic in nature.

35. What is cinnabar? How is metal extracted from cinnabar? Explain briefly.

Answer. Cinnabar is HgS.

Mercury is obtained by roasting cinnabar. HgO formed is thermally unstable and gives mercury.

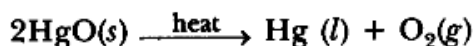

or

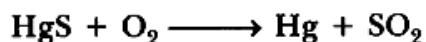

Mercury can be purified by distillation.

36. (a) Write the electron dot structures for potassium and chlorine.

(b) Show the formation of KCl by the transfer of electrons.

(c) Name the ions present in the compound, KCl.

Chemical Reaction:

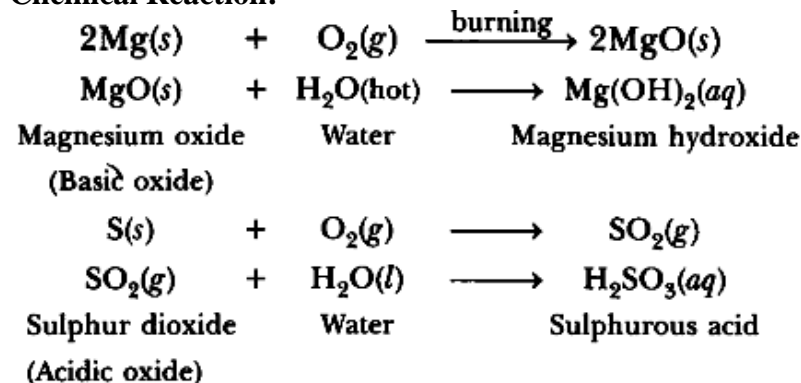

Conclusion: Most of the metallic oxides are basic in nature whereas most of the non-metallic oxides are acidic in nature.

40. Suggest a method of reduction for the following metals during their metallurgical processes:
- metal 'A' which is one of the last, second or third position in the reactivity.
 - metal 'B' which gives vigorous reaction even with water and air.
 - metal 'C' which is kept in the middle of activity series.

Answer.

- 'A' can be obtained by chemical reduction using carbon or carbon monoxide as reducing agent.
- 'B' can be obtained by electrolytic reduction.
- 'C' can be reduced by reducing agent like 'Al'.

41. (a) Explain the formation of ionic compound CaO with electron dot structure. Atomic number of calcium and oxygen are 20 and 8 respectively.
(b) Name the constituent metals of bronze.

Answer.

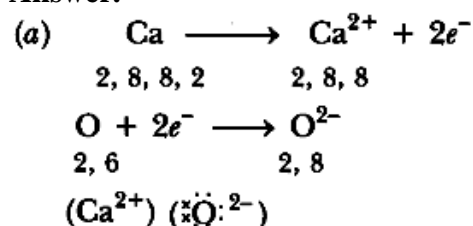

(b) Bronze is made up of copper and tin.

42. A metal 'X' acquires a green colour coating on its surface on exposure to air.
- Identify the metal 'X' and name the process responsible for this change.
 - Name and write chemical formula of the green coating formed on the metal.
 - List two important methods to prevent the process.

Answer.

- Metal is copper. The process is corrosion.
- Basic copper carbonate $[\text{CuCO}_3 \cdot \text{Cu}(\text{OH})_2]$.
- It should be coated with tin
 - It should be mixed with other metals to form alloys

43. Write balanced equations for the reaction of:

- aluminium when heated in air. Write the name of the product.
- iron with steam. Name the product obtained.
- calcium with water. Why does calcium start floating in water?

Answer.

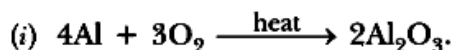

The product formed is aluminium oxide.

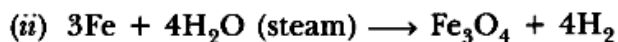

The product obtained is iron(II) iron (III) oxide.

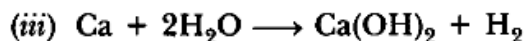

The bubbles of hydrogen stick to the surface of metal that is why it floats.

44. Write balanced chemical equations for the following reactions:

(a) Dilute sulphuric acid reacts with aluminium powder.

(b) Dilute hydrochloric acid reacts with sodium carbonate.

(c) Carbon dioxide is passed through lime water.

Answer.

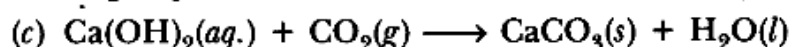
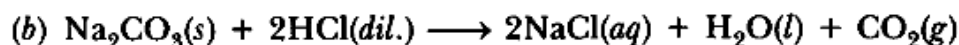
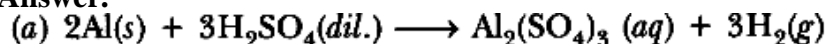

Lime water

(white ppt)

45. What is meant by 'rusting'? With labelled diagrams, describe an activity to find out the conditions under which iron rusts.

Answer. The process in which iron reacts with oxygen in the presence of moisture to form reddish brown coating of hydrated ferric oxide [Iron (III) oxide]. $Fe_2O_3 \cdot xH_2O$

Activity:

(i) Take three boiling tubes A, B and C.

(ii) Pour some water in test tube A Put iron nails in it and cork it.

(iii) Pour boiled distilled water in another test tube B and put iron nails in it. Add 1 ml of oil over it such that oil floats over it and prevents the air from entering.

(iv) Take some iron nails in test tube C and put some anhydrous calcium chloride in it and cork it.

(v) Leave all the three test tubes for one day and then observe.

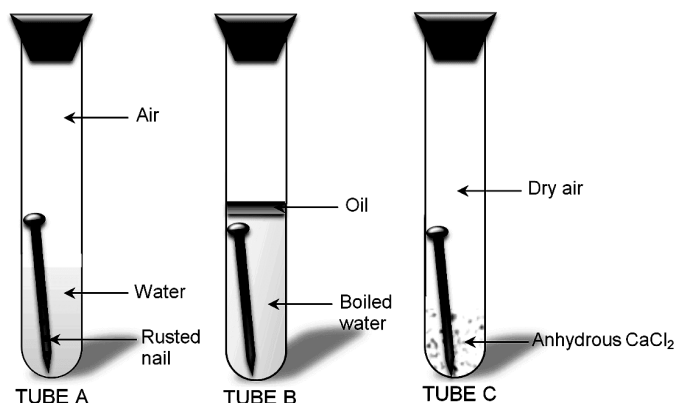

Observation: Iron nails get rusted in test tube A because both air and water are present in it. Iron nails do not get rusted in B because there is water but no air. In C, rusting will not take place because there is neither air nor water. Conclusion: Iron gets rusted in the presence of air and water.

46. (a) Show the formation of Na_2O by the transfer of electrons between the combining atoms.

(b) Why are ionic compounds usually hard?

(c) How is it that ionic compounds in the solid state do not conduct electricity but they do so when in molten state?

Answer.

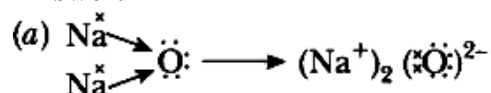

- (b) It is due to strong force of attraction between oppositely charged ions.
 (c) In solid state, ions are not free to move whereas in molten state ions are free to move, therefore, they conduct electricity in molten state.

47. (a) **Show on a diagram the transfer of electrons between the atoms in the formation of MgO. Write symbols of cation and anion present in MgO.**

(b) **Name the solvent in which ionic compounds are generally soluble.**

(c) **Why are aqueous solutions of ionic compounds able to conduct electricity?**

Answer.

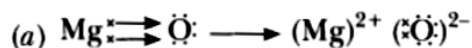

MgO contains Mg^{2+} as cation and O^{2-} as anion.

(b) Ionic compounds are soluble in water.

(c) It is because aqueous solutions consist of ions which can move freely in them and carry current.

48. **What are amphoteric oxides? Choose the amphoteric oxides from amongst the following oxides:**

Na_2O , ZnO , Al_2O_3 , CO_2 , H_2O

Answer. Those oxides which react with acids as well as bases to produce salts and water are called amphoteric oxides, e.g. Na_2O , ZnO , are amphoteric oxides among given oxides.

49. **Define the terms:**

(i) **mineral**

(ii) **ore, and**

(iii) **gangue.**

Answer.

(i) **Mineral:** It is a naturally occurring substance from which metal may or may not be extracted profitably or economically, e.g. Al cannot be extracted profitably from mica.

(ii) **Ore:** It is a rocky material which contains sufficient quantity of mineral so that metal can be extracted profitably, e.g. zinc blende is an ore of zinc from which zinc can be extracted profitably.

(iii) **Gangue:** It is a rocky material which is present along with the mineral in the ore, e.g. FeO is gangue in extraction of copper.

50. **An ore on heating in air produces sulphur dioxide. Which process would you suggest for its concentration? Describe briefly any two steps involved in the conversion of this concentrated ore into related metal.**

Answer. It is concentrated by froth-floatation process.

(i) **Roasting:** The concentrated sulphide ore is heated strongly in the presence of oxygen to convert it into its oxide.



(ii) **Reduction :** This oxide of metal is reduced with suitable reducing agent to get free metal.



51. **Give reasons for the following observations:**

(i) **Ionic compounds in general have high melting and boiling points.**

(ii) **Highly reactive metals cannot be obtained from their oxides by heating them with carbon.**

(iii) **Copper vessels get a green coat when left exposed to air in the rainy season.**

Answer. (i) Ionic compounds have high melting and boiling points due to strong force of attraction between oppositely charged ions.

(ii) It is because these metals themselves are strong reducing agents. Therefore, cannot be reduced by reducing agent like carbon.

(iii) Copper vessels react with CO_2 , O_2 and moisture to form green-coloured basic copper carbonate

$[\text{CuCO}_3 \cdot \text{Cu}(\text{OH})_2]$.

52. State reasons for the following observations:

- (i) The shining surface of some metals becomes dull when exposed to air for a long time.
- (ii) Zinc fails to evolve hydrogen gas on reacting with dilute nitric acid.
- (iii) Metal sulphides occur mainly in rocks but metal halides occur mostly in sea and lake waters.

Answer.

- (i) It is because metal reacts with substances present in atmosphere to form surface compounds which make it dull.
- (ii) It is because dil. HNO_3 is an oxidising agent therefore zinc gives NO and not H_2 with dil. HNO_3 .
- (iii) It is because sea water contains sodium chloride due to which metal halides are formed, whereas sulphur is found below rocks. Therefore, metal – sulphides are formed in rocks.

53. State reasons for the following:

- (i) Electric wires are covered with rubber like material.
- (ii) From dilute hydrochloric acid, zinc can liberate hydrogen gas but copper cannot.
- (iii) Sulphide ore of a metal is first converted to its oxide to extract the metal from it.

Answer.

- (i) It is because rubber is an insulator and does not allow current to flow through it.
- (ii) Zinc is more reactive than hydrogen. Therefore, it can displace hydrogen from dilute HCl whereas copper cannot, because it is less reactive than hydrogen. ,
- (iii) It is because it is easier to reduce oxide ore as compared to sulphide ore.

Long Answer Type Question [5 Marks]

54. (a) Write electron dot diagram for chlorine (At No. 17) and calcium (At No. 20).

Show the formation of calcium chloride by transfer of electrons.

(b) Identify the nature of above compound and explain three physical properties of such compound. Answer.

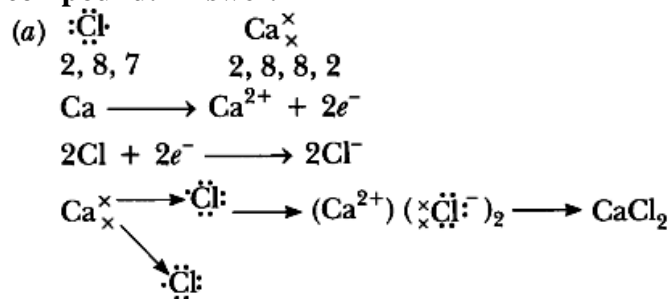

(b) It is ionic compound.

Physical properties

1. It is hard and solid.
2. It has high melting and boiling point.
3. It soluble in water.

55. (a) An ore on treatment with dilute hydrochloric acid produces brisk effervesces. What type of ore is this? What steps will be required to obtain metal from the enriched ore. ,

(b) Copper coin is kept immersed in silver nitrate solution for some time. What change will take place in coin and colour of the solution ? Write balanced chemical equation of the reaction involved.

Answer.

(a) Carbonate ore:

(i) **Calcination:** Carbonate ore is heated in limited supply of air and oxide is obtained, e.g.

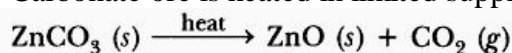

(ii) **Reduction with carbon:** Oxide ore is heated with carbon



(c) Common salt conducts electricity only in the molten state. Why?

(d) Why is melting point of NaCl high?

Answer.

(a) (i) Ionic bond

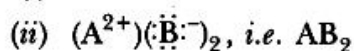

(b) $Mg \longrightarrow Mg^{2+} + 2e^{-}$

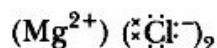
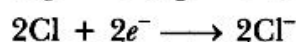

(c) Na^{+} and Cl^{-} are free to move in molten state but not in solid state.

(d) It is due to strong force of attraction between Na^{+} and Cl^{-} .

60. (a) Carbon cannot be used as reducing agent to obtain Mg from MgO. Why?

(b) How is sodium obtained from molten sodium chloride? Give equation of the reactions.

(c) How is copper obtained from its sulphide ore? Give equations of the reactions.

Answer.

(a) It is because 'Mg' is stronger reducing agent than carbon.

(b) Sodium is obtained from molten NaCl by electrolysis.

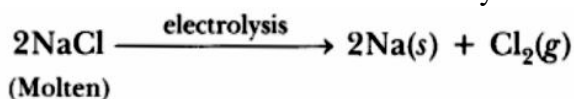

(c) Copper ore is concentrated by froth-floatation process.



Bessemerisation: Copper oxide reacts with Cu_2S on heating to form Blister copper and SO_2 .

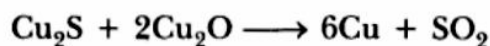

Blister Copper is purified by electrolytic refining.

61. How is the method of extraction of metals high up in the reactivity series different from that for metals in the middle? Why the same process cannot be applied for them? Explain giving equations, the extraction of sodium.

Answer. Metals high up in the series are obtained by electrolytic reduction because these metals are strong reducing agents and therefore, cannot be obtained by chemical reduction.

Metals in middle of series are less reactive and can be obtained by chemical reduction. The same process can not be used for both of them as highly reactive metals can not be obtained by chemical reduction.

Extraction of sodium is done by electrolysis of molten sodium chloride.

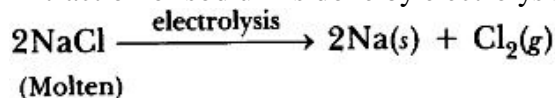

62. Write the names and symbols of two most reactive metals. Explain by drawing electronic structure how any one of the two metals react with a halogen. State any four physical properties of the compound formed.

Answer. K(Potassium) and Na(Sodium) are the two most reactive metals. K' and Na' are electronic structures as they have one valence electron.

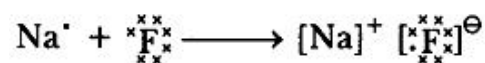
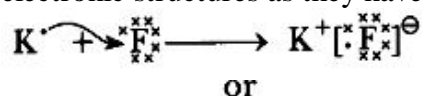

where 'F' is a halogen.

Four physical properties of the compounds formed by these elements and halogens are:

- (i) They have high melting point.
- (ii) They are soluble in water.
- (iii) They conduct electricity in molten state not in solid state.
- (iv) They are solid and somewhat hard.

63. A metal 'M' which is one of the best conductor of heat and electricity used in making electric wires is found in nature as sulphide ore M_2S ?

(i) Name the metal 'M'

(ii) Which process will be suitable for extraction of this metal M from its ore M_2S ? Write the balanced chemical reactions involved in the process of 'extraction.

(iii) With the help of a labelled diagram, explain the process of electrolytic refining of the metal.

Answer.

(i) Copper

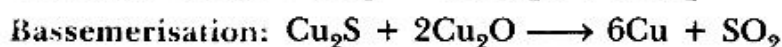
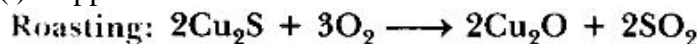

(ii) It is concentrated by froth-floatation process.

Impure copper is purified by electrolytic refining.

(iii)

1) The electrolytic tank containing acidified copper sulphate solution as electrolyte.

2) A thick block of impure copper metal is made anode.

3) A thin strip of pure copper metal is made cathode.

On passing electric current, impure copper from the anode dissolves and goes into copper sulphate solution and pure copper from copper sulphate deposits on cathode. Thus pure copper metal is produced on the cathode. The soluble impurities go into the solution whereas insoluble impurities collect below the anode as anode mud.

At cathode, $Cu^{2+} + 2e^- \longrightarrow Cu$

At anode, $Cu - 2e^- \longrightarrow Cu^{2+}$

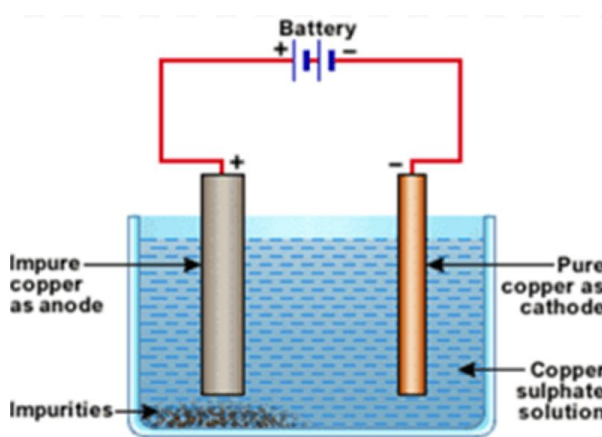

64. Give reasons for the following:

(i) Silver and copper lose their shine when they are exposed to air. Name the substance formed on their surface in each case.

(ii) Tarnished copper vessels are cleaned with tamarind juice.

(iii) Aluminium is more reactive than iron yet there is less corrosion of aluminium as compared to iron when both are exposed to air.

Answer.

(i) These metals get corroded. Silver forms black Ag_2S (silver sulphide) and copper form greenish layer of basic copper carbonate $\text{CuCO}_3 \cdot \text{Cu}(\text{OH})_2$.

(ii) Tamarind contains acid which reacts with basic copper carbonate and product gets dissolved and removed from copper vessel.

(in) Aluminium forms oxide layer on its surface which does not further react with air.

65. (a) Write the electron dot structures of sodium, oxygen and magnesium.

(b) Show the formation of Na_2O and MgO by transfer of electrons. Name the ions present in these compound.

(c) List three properties of ionic compounds.

Answer.

(a) Na^\cdot , $\cdot\ddot{\text{O}}\cdot$, Mg^\cdot

(b) $\text{Na}^\cdot \rightarrow \ddot{\text{O}} \rightarrow (\text{Na}^+)_2 (\ddot{\text{O}}^{2-})$

$\text{Mg}^\cdot \rightarrow \ddot{\text{O}} \rightarrow (\text{Mg}^{2+}) (\ddot{\text{O}}^{2-})$

Na_2O contains Na^+ and O^{2-} ions.

MgO contains Mg^{2+} and O^{2-} ions.

(i) They are solids having high melting point.

(ii) They are soluble in water.

(iii) They conduct electricity in molten state as well as in aqueous solution.

66. What are alloys? How are they made? Name the constituents and uses of brass, bronze and solder.

Answer. Alloys are homogeneous mixtures of two or more metals. One of them can be a non-metal also. They are made by melting a metal which is in large amount first and then adding the other metal.

Brass contains copper and zinc. It is used for making decorative articles. Bronze contains copper and tin. It is used for making statues and medals. Solder contains lead and tin. It is used for soldering purposes.

67. A metal (E) is stored under kerosene. When a small piece of it is left open in the air, it catches fire. When the product formed is dissolved in water, it turns red litmus to blue.

(i) Name the metal (E).

(ii) Write the chemical equation for the reaction when it is exposed to air and when the product is dissolved in water.

(iii) Explain the process by which the metal is obtained from its molten chloride.

Answer.

(i) 'E' is sodium which catches fire in presence of moisture.

(ii) $4\text{Na} + \text{O}_2 \rightarrow 2\text{Na}_2\text{O}$

$\text{Na}_2\text{O} + \text{H}_2\text{O} \rightarrow 2\text{NaOH}$

(iii) Electrolytic reduction: Electric current is passed through molten NaCl . Sodium is formed at cathode and chlorine gas is liberated at anode.

$2\text{NaCl} \xrightarrow{\text{electrolysis}} 2\text{Na} + \text{Cl}_2$
Molten

68. (a) Name the main ore of mercury. How is mercury obtained from its ore? Give balanced chemical equation.

(b) What is thermite reaction? How is it used to join the railway tracks or cracked machine parts?

(c) Name the method used to extract metals of high reactivity.

Answer.

(a) Cinnabar

Mercury is obtained from its ore by roasting.



(b) When aluminium is heated with Fe_2O_3 to get molten iron, it is called thermite reaction.

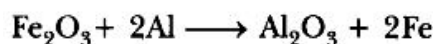

Molten iron is used to weld broken railway tracks.

(c) Electrolytic reduction

69. (a) How can the metals at the top of the reactivity series be extracted from their ores?

Explain with an example.

(b) Name any one alloy made from

(i) a metal and a non-metal, and

(ii) two metals.

Answer.

(a) These metals are extracted by electrolytic reduction, e.g. aluminium is obtained from bauxite by electrolytic reduction.

(b) (i) Steel is made up of iron and carbon.

(ii) Brass is made up of copper and zinc.

70. With the help of a suitable example, explain how ionic compounds are formed. State any three general properties of ionic compounds.

Answer. Ionic compounds are formed by transfer of electrons from metal to non-metals, e.g.

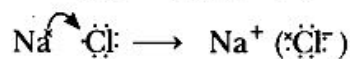

General Properties:

(i) They are the solids having high melting point.

(ii) They are soluble in water.

(iii) They conduct electricity in molten state as well as in aqueous solution.

71. (a) Explain with an example how the metal (X) which is low in reactivity series and metal (Y) which is high in the reactivity series are obtained from their compounds by reduction process.

(b) Write the electronic configurations of sodium and chlorine. Show the formation of sodium chloride from sodium and chlorine by the transfer of electrons.

(c) List any two observations when a highly reactive metal is dropped in water.

Answer.

(a) 'X' is obtained by chemical reduction.

'Y' is obtained by electrolytic reduction.

(b) Na (2, 8, 1)

Cl (2, 8, 7)

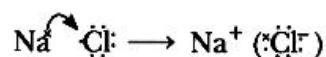
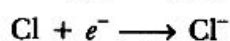

- (c) (i) Metal will catch fire.
 (ii) Alkali solution is formed which turns red litmus blue.

72. (a) **The reaction of metal (X) with ferric oxide is highly exothermic. Metal (X) is obtained from its oxides by electrolytic reduction. Identify (X) and write its reaction with ferric oxide.**

(b) **Give reason to justify that aluminium oxide is an amphoteric oxide. Also, give another example of amphoteric oxide.**

(c) **Mention constituent metals present in bronze.**

Answer. (a) 'X' is 'Al'



(b) Al_2O_3 reacts with acid as well as base therefore it is amphoteric oxide.

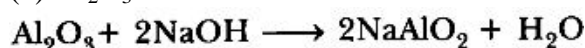

Zinc oxide is also an amphoteric oxide.

(c) Bronze contains copper and tin.

73. **No reaction takes place when granules of a solid 'A' are mixed with a powder of solid 'B'. However when the mixture is heated, a reaction starts with evolution of much heat. Product 'C' of the reaction settles down as a liquid metal and solid product 'D' keeps floating over the liquid 'C'. This reaction is sometimes used for making metals for ready use in odd places.**

(i) **Based on this information, make assumptions about 'A' and 'B' and corresponding deductions about 'C' and 'D' and write a balanced chemical equation for the reaction.**

Include in the chemical equation about physical states of the reactants and products, need of heating for starting the reaction and the reaction being exothermic.

(ii) **Name two types of chemical reactions to which this reaction can belong.**

Answer.

(i) 'A' is aluminum, 'B' is ferric oxide [Iron(III) oxide],

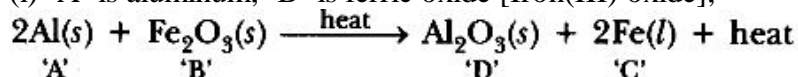

(ii) This reaction is displacement reaction because Al is displacing 'Fe'. It is also a redox reaction because Al is reducing agent and Fe_2O_3 is oxidising agent.

74. (a) **What is meant by corrosion? Name any two methods used for the prevention of corrosion.**

(b) **Suppose you have to extract metal M from its enriched sulphide ore. If M is in the middle of the reactivity series, write various steps used in extracting this metal.**

Answer. (a) Corrosion is a process in which metal reacts with substances present in the environment to form surface compounds.

Prevention:

(i) Galvanisation is a process to prevent corrosion of iron.

(ii) Electroplating is also used to prevent corrosion.

(b)(i) Concentration of ores: Sulphide ore will be concentrated by froth- floatation process. Sulphide ore will be collected in froth whereas gangue will be left behind.

(ii) Roasting: Sulphide ore is heated strongly in the presence of O_2 to form metal oxide and sulphur dioxide.



(iii) Reduction: MO reacts with carbon (acts as reducing agent) to form metal and CO.

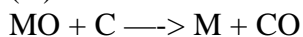

(iv) Electrolytic refining: Impure metal 'M' is purified by electrolytic refining. Impure metal is taken as anode, pure metal is taken as cathode, soluble salt of metal is taken as electrolyte. Impure metal forms metal ions which gain electrons and form pure metal at cathode.

75. (a) Distinguish between ionic and covalent compounds under the following properties:
- (i) Strength of forces between constituent elements.
 - (ii) Solubility of compounds in water.
 - (iii) Electrical conduction in substances.
- (b) Explain how the following metals are obtained from their compounds by the reduction process:
- (i) Metal M which is in the middle of the reactivity series.
 - (ii) Metal N which is high up in the reactivity series.
- Give one example of each type.
- Answer.

Ionic Compounds	Covalent Compounds
(i) Strength – They have strong forces of attraction	They have weak forces of attraction.
(ii) Solubility – They are soluble in water	They are insoluble in water
(iii) Conduction – They conduct electricity in aqueous solution.	They do not conduct electricity in aqueous solution.

- (b) (i) Metal M which is in the middle of the reactivity series is reduced by aluminium, e.g.
- $$3\text{MnO}_2(\text{s}) + 4\text{Al}(\text{s}) \longrightarrow 2\text{Al}_2\text{O}_3(\text{s}) + 3\text{Mn}(\text{l})$$
- (ii) Metal N will be obtained by electrolytic reduction, e.g. Al is obtained by electrolytic reduction.



CARBON AND ITS COMPOUNDS

VERY SHORT ANSWER TYPE QUESTION [1 Mark]

1. Give the names of the following functional groups:

(i) —OH (ii) —COOH

Answer. (i) Alcohol group (ii) Carboxylic acid group

2. What is the difference in the molecular formula of any two consecutive members of a homologous series of organic compounds?

Answer. —CH₂— is the difference in the molecular formula of any two consecutive members of a homologous series of organic compounds.

3. Name the carbon compound which on heating with excess of concentrated sulphuric acid at 443 K gives ethene.

Answer.

CH₃CH₂OH, ethanol

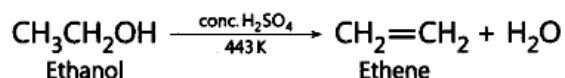

4. What is meant by a saturated hydrocarbon?

Answer. Those hydrocarbons in which valency of carbon is satisfied by single bonds only are called saturated hydrocarbons.

5. Name the compound formed when ethanol is warmed with ethanoic acid in the presence of a few drops of conc. H₂SO₄

Answer.

Ethyl ethanoate is formed.

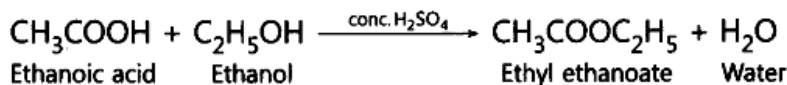

6. Draw the structure of CH₃COOH molecule.

Answer.

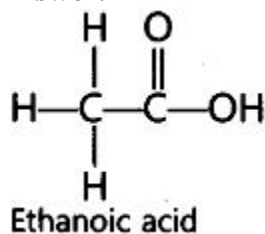

7. Draw the structure of ethanol molecule.

Answer.

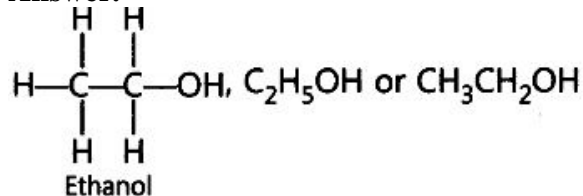

8. What happens when a small piece of sodium is dropped into ethanol?

Answer.

Hydrogen gas will be evolved.

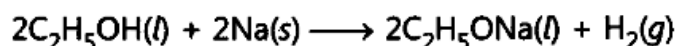

9. Carbon has four electrons in its valence shell. How does carbon attain stable electronic configuration.

Answers. By sharing four electrons with other atoms.

10. State two characteristic features of carbon which when put together give rise to large number of carbon compounds.

Answer. (i) Catenation (ii) Tetravalency of carbon

11. Write the structural formula of chloroethane.

Answer.

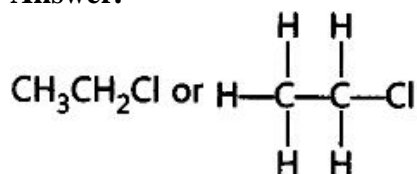

12. How many covalent bonds are there in a molecule of ethane (C_2H_6)?

Answer. There are 7 covalent bonds in a molecule of ethane.

13. Write the electron dot structure of ethene molecule (C_2H_4).

Answer.

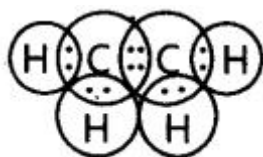

Ethene

14. Write the electron dot structure of ethane molecule (C_2H_6).

Answer.

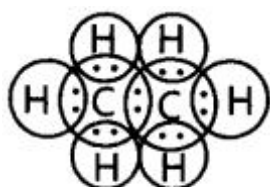

Ethane

15. Draw the structure of butanone molecule, $\text{CH}_3\text{COC}_2\text{H}_5$.

Answer.

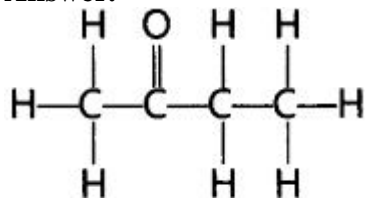

Butanone

16. Draw the structure of the hexanal molecule, $\text{C}_5\text{H}_{11}\text{CHO}$.

Answer.

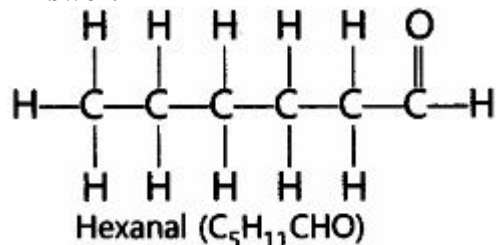

17. Name the following compound:

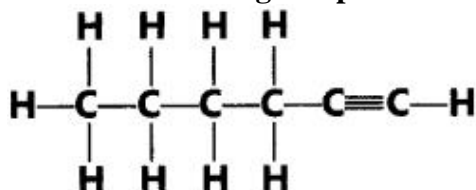

Answer. 1-Hexyne is IUPAC name of the compound.

18. Butanone is a four carbon per molecule compound. Name the functional group present in it.

Answer. Ketone

19. Name the functional group present in each of the following organic compounds:

(i) C_2H_5Cl

(ii) C_2H_5OH

Answer.

(i) ($-Cl$) Halogen (Chloro)

(ii) ($-OH$) Alcohol

20. Name the functional group present in each of the following compounds:

(i) $HCOOH$

(ii) C_2H_5CHO

Answer.

(i) $-COOH$ (Carboxylic acid)

(ii) $-CHO$ (Aldehyde)

21. Name the functional group present in each of the following organic compounds:

(i) CH_3COCH_3

(ii) C_2H_5COOH

Answer.

(i) Ketone ($\begin{array}{c} O \\ || \\ -C- \end{array}$)

(ii) Carboxylic acid ($-COOH$)

22. Write the name and formula of the second member of the carbon compounds having functional group $-OH$.

Answer.

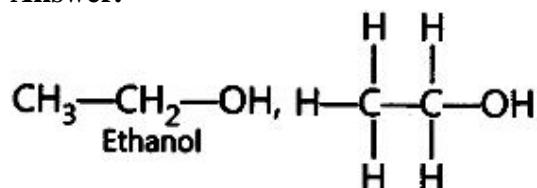

23. Write the name and formula of the first member of the carbon compounds having functional group $-CHO$.

Answer.

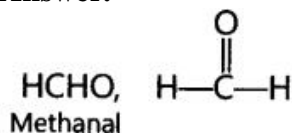

24. Write the name and formula of the first member of the carbon compounds having functional group $-COOH$.

Answer.

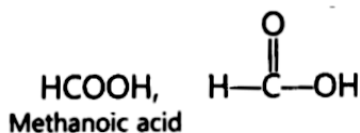

25. Write the name and formula of the 2nd member of the series of carbon compounds whose general formula is $C_nH_{2n+1}OH$

Answer. Ethanol, C_2H_5OH or CH_3CH_2OH

26. Write the name and formula of the 2nd member of the series of carbon compounds whose general formula is C_nH_{2n} .

Answer.

C_3H_6 , $H_2C=CH-CH_3$

Propene is second member of series whose general formula is C_nH_{2n} .

SHORT ANSWER TYPE QUESTIONS[I] [2 Marks]

27. (a) Give a chemical test to distinguish between saturated and unsaturated hydrocarbons.
 (b) (i) Name the products formed when ethanol burns in air. ‘
 (ii) What two forms of energy are liberated on burning alcohol?
 (c) Why is the reaction between methane and chlorine considered a substitution reaction?

Answer.

(a) Add bromine water. Saturated hydrocarbons do not react whereas unsaturated hydrocarbon will decolourise bromine water.

(b) (i) CO_2 and H_2O are formed.



(ii) Heat energy and light energy

(c) It is because ‘Cl’ atom substitutes ‘H’ atom of methane to form chloromethane and hydrogen chloride.

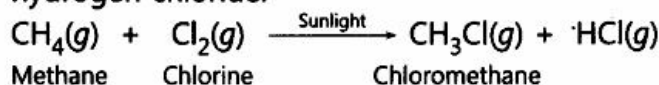

28. (a) Why are covalent compounds generally poor conductors of electricity?
 (b) Name the following compound:

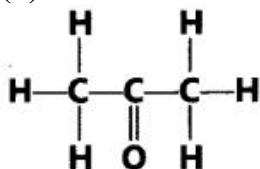

(c) Name the gas evolved when ethanoic acid is added to sodium carbonate. How would you prove the presence of this gas?

Answer.

(a) It is because they do not form ions.

(b) Propanone

(c) Carbon dioxide gas. It turns lime water milky.

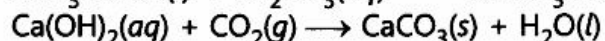
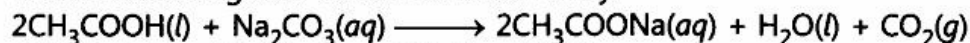

Calcium Carbon Calcium
hydroxide dioxide carbonate

29. Write the name and molecular formula of an organic compound having its name suffixed with ‘-ol and having two carbon atoms in the molecule. With the help of a balanced chemical equation indicate what happens when it is heated with excess of conc. H_2SO_4 .

Answer.

It is ethanol, its molecular formula is $\text{C}_2\text{H}_6\text{O}$.

Ethanol forms ethene, when heated with conc. H_2SO_4 .

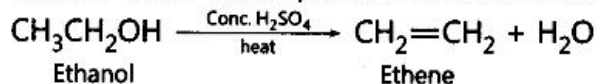

30. Explain why carbon generally forms compounds by covalent bonds.

Answer. Carbon cannot lose four electrons easily because very high energy is required. It cannot gain four electrons easily because six protons cannot hold 10 electrons. It can easily share four electrons forming covalent bonds.

31. Write the names and molecular formula of two organic compounds having functional group suffixed as ‘-oic acid’. With the help of a balanced chemical equation and explain what happens when any one of them reacts with sodium hydroxide.

Answer.

Methanoic acid, its molecular formula is CH_2O_2 .

Ethanoic acid, its molecular formula is $\text{C}_2\text{H}_4\text{O}_2$.

When acid reacts with sodium hydroxide, its sodium salt and water is formed.

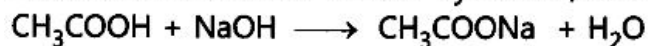

Ethanoic acid

Sodium ethanoate Water

32. What is the IUPAC name of (i) $\text{CH}_3\text{—CH}_2\text{—CH=CH}_2$ (ii) CH_3CHO ?

Answer. (i) But-1-ene (ii) Ethanal

33. Atom of an element contains five electrons in its valence shell. This element is major component of air. It exists as a diatomic molecule.

(i) Identify the element.

(ii) Show the bond formed between two atoms of this element.

(iii) Write the nature of the bond between the two atoms.

Answer.

(i) Nitrogen.

(ii)

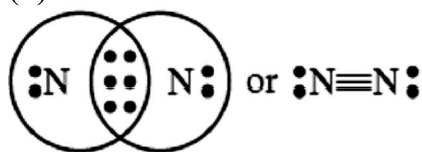

(iii) Covalent bond.

34. Write IUPAC names of (i) $\text{CH}_3\text{COCH}_2\text{CH}_3$

(ii)

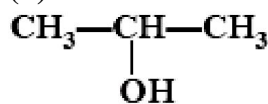

(iii) HCOOH (iv) $\text{CH}_3\text{COOCH}_3$

Answer. (i) Butanone (ii) 2-Propanol (iii) Methanoic acid (iv) Methyl ethanoate

35. What is a homologous series? Which two of the following organic compounds belong to the same homologous?

CH_3 , C_2H_6 , $\text{C}_2\text{H}_6\text{O}$, $\text{C}_2\text{H}_6\text{O}_2$, CH_4O

Answer. Homologous series is a series of organic compounds which have same functional group and similar chemical properties. Each member of this series is differ by $\text{—CH}_2\text{—}$ in its molecular formula and 14 u in its molecular mass.

$\text{C}_2\text{H}_6\text{O}$ ($\text{C}_2\text{H}_5\text{OH}$) and CH_4O (CH_3OH) belong to same homologous series.

SHORT ANSWER TYPE QUESTIONS[II] [3 Marks]

36. What is meant by a functional group in an organic compound? Name the functional group present in

(i) $\text{CH}_3\text{CH}_2\text{OH}$

(ii) CH_3COOH

(b) State one point of difference between soap and synthetic detergent.

Answer.

(a) Functional group is an atom or group of atoms or reactive part of compound, which determines chemical properties of compounds.

(i) —OH (Alcohol)

(ii) —COOH (Carboxylic acid)

(b) Soaps do not work well with hard water, detergents work well with hard water.

37. Give reasons for the following observations:

(a) The element carbon forms a very large number of compounds.

(b) Air holes of a gas burner have to be adjusted when the heated vessels get blackened by

the flame.

(c) Use of synthetic detergents causes pollution of water.

Answer.

(a) Carbon forms large number of compounds since carbon is small in size and can form stable covalent bonds (catenation) and it shows tetravalency.

(b) Air holes of gas burner are made open (adjusted) so that air can pass through, which is needed for complete combustion, so that heated vessels do not get blackened.

(c) Some synthetic detergents are non-biodegradable, therefore, cause pollution of water.

38. **What is ethanoic acid? Write the formula of the functional group present in this acid.**

What special name is given to its 5 – 8% solution in water? How does ethanoic acid react with sodium carbonate? Write a chemical equation of the reaction and common name of the salt produced.

Answer.

CH_3COOH is ethanoic acid. $-\text{COOH}$ is the formula of the functional group present in ethanoic acid.

Its 5 to 8% solution in water is called vinegar.

Sodium ethanoate and brisk effervescence due to carbon dioxide gas are formed on reaction of ethanoic acid with sodium carbonate.

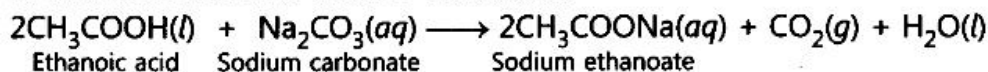

The salt produced has common name sodium acetate.

39. **An ester has the molecular formula $\text{C}_4\text{H}_8\text{O}_2$. Write its structural formula. What happens when this ester is heated in the presence of sodium hydroxide solution? Write the balanced chemical equation for the reaction and name the products. What is a saponification reaction?**

Answer.

There are three possible structural formulae of ester with molecular formula $\text{C}_4\text{H}_8\text{O}_2$.

$\text{CH}_3\text{CH}_2\text{COOCH}_3$, $\text{HCOOCH}_2\text{CH}_2\text{CH}_3$, $\text{CH}_3\text{COOC}_2\text{H}_5$

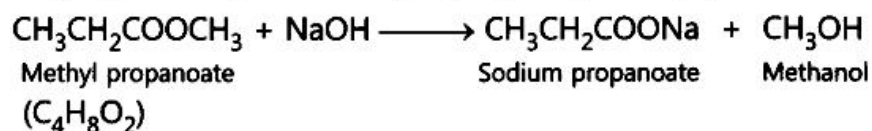

Or

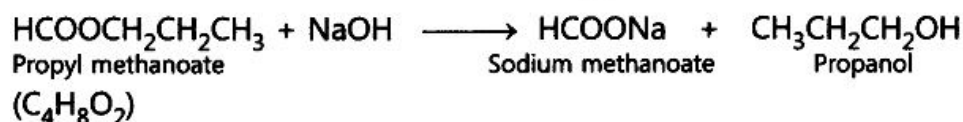

Or

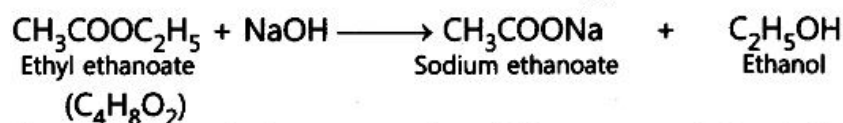

Saponification is the process in which an ester is treated with sodium hydroxide to form sodium salt of acid and alcohol is formed.

40. **Out of HCl and CH_3COOH , which one is a weak acid and why? Describe an activity to support your answer.**

Answer. Acetic acid (CH_3COOH) is a weaker acid because it does not dissociate completely into its ions in aqueous solution. .

Activity: Add zinc metal in HCl and CH_3COOH respectively. The hydrogen gas will be evolved faster in HCl and slowly in CH_3COOH . It shows acetic acid is a weak acid.

Alternative Method:

If we use pH paper, the colour of pH paper will be dark red in HCl and light red in CH_3COOH which shows HCl is a strong acid and CH_3COOH is a weak acid.

41. Name the functional group of organic compounds that can be hydrogenated. With the help of suitable example explain the process of hydrogenation mentioning the conditions of the reaction and any one change in physical property with the formation of the product. Name any one natural source of organic compounds that are hydrogenated.

Answer.

Double bond =, Triple bond \equiv are functional groups (reactive part of compounds) which can be hydrogenated.

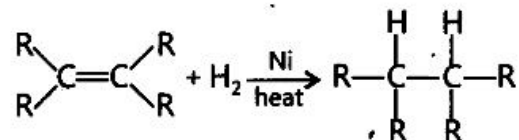

When unsaturated hydrocarbons are heated with hydrogen in the presence of nickel as catalyst, saturated hydrocarbons are formed. If the starting unsaturated hydrocarbons are liquids, they will change into solids. Vegetable oils are hydrogenated to form vegetable ghee. Plants are natural sources of vegetable oils which can be hydrogenated.

42. An organic compound 'A' is an essential constituent of wine and beer. Oxidation of 'A' yields an organic acid 'B' which is present in vinegar. Name the compounds 'A' and 'B' and write their structural formula. What happens when 'A' and 'B' react in the presence of an acid catalyst? Write the chemical equation for the reaction.

Answer.

'A' is ethanol ($\text{C}_2\text{H}_5\text{OH}$) which is essential constituent of wine and beer and 'B' is acetic acid (CH_3COOH) which is present in vinegar.

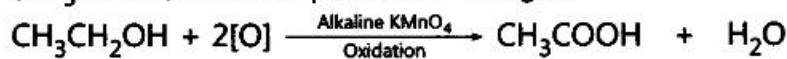

(Present in wine
and beer)
'A'

Acetic acid
(Present in vinegar)
'B'

When 'A' and 'B' react in the presence of an acid catalyst, ethyl ethanoate is formed.

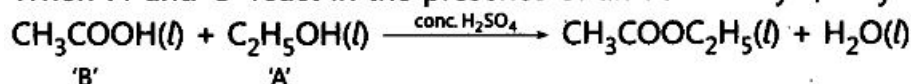

'B'

'A'

43. What is ethanol? State its two properties. What happens when it is heated with excess of conc. H_2SO_4 at 443 K? What role does conc. H_2SO_4 play in this reaction? Write chemical equation of the reaction involved and the structural formula of the main product formed.

Answer.

Ethanol is $\text{C}_2\text{H}_5\text{OH}$.

(i) It has specific smell.

(ii) It is soluble in water.

When ethanol is heated with excess of conc. H_2SO_4 , ethene is formed along with water.

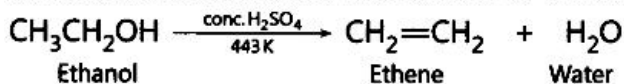

Ethanol

Ethene

Water

Conc. H_2SO_4 acts as dehydrating agent.

Structural formula of ethene is $\text{H}-\overset{\text{H}}{\underset{|}{\text{C}}}=\overset{\text{H}}{\underset{|}{\text{C}}}-\text{H}$.

44. With the help of balanced chemical equations explain what happens when ethanol is heated with (i) alkaline solution of potassium permanganate, (ii) excess concentrated sulphuric acid at 443 K. Mention any two uses of ethanol.

Answer.

(i) Ethanol gets oxidised to ethanoic acid.

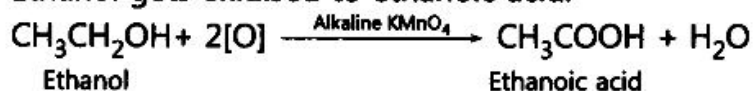

(ii) Ethene will be formed.

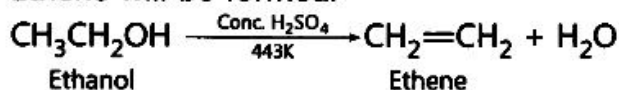

Uses:

- (i) It is used in tonics and cough syrups. (ii) It is used as fuel.
(iii) It is used as solvent. (iv) It is used in wine, beer and whisky.
(any two)

45. What is an 'esterification' reaction? Describe an activity to show esterification.

Answer. When carboxylic acid reacts with alcohol in presence of conc. H₂SO₄, pleasant fruity smelling compound is formed.

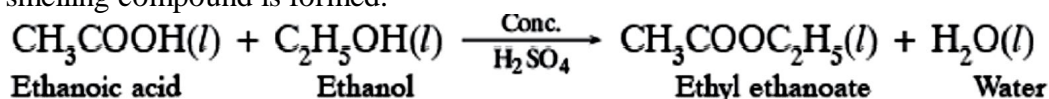

Activity: Take 1 ml of ethanol in a test tube. Add 1 ml of acetic acid in this test tube.

Add few drops of conc. H₂SO₄ in the mixture.

Heat the content on water bath for 5 minutes.

Smell the resulting mixture formed.

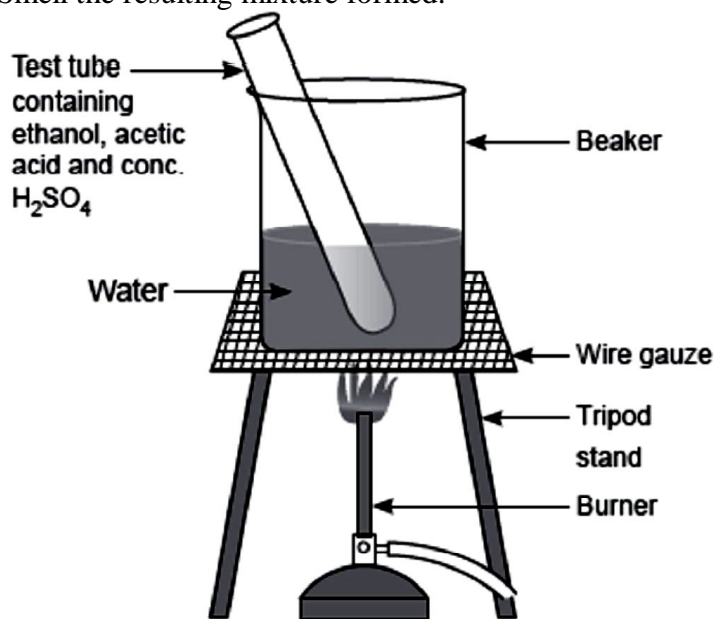

Result: Pleasant fruity smelling ester is formed.

46. Write a chemical equation in each case to represent the following types of chemical reactions of organic compounds:

(i) Oxidation reactions

(ii) Addition reactions

(iii) Substitution reactions

Answer.

(i) Oxidation reaction:

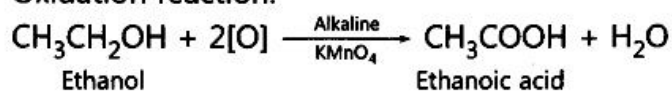

(ii) Addition reaction:

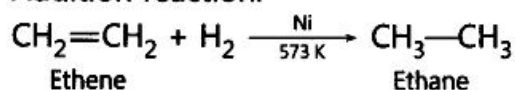

(iii) Substitution reaction:

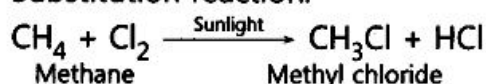

47. Write chemical equations for what happens when

(i) sodium metal is added to ethanoic acid.

(ii) solid sodium carbonate is added to ethanoic acid.

(iii) ethanoic acid reacts with a dilute solution of sodium hydroxide.

Answer.

(i) H₂ gas is evolved.

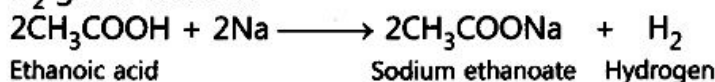

(ii) Brisk effervescence due to carbon dioxide gas is formed.

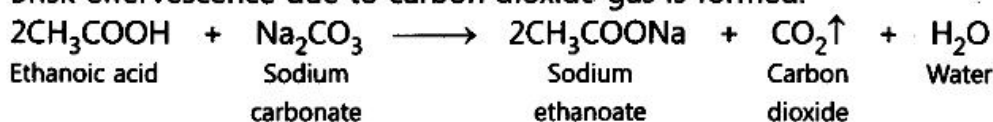

(iii) Sodium ethanoate and water are formed.

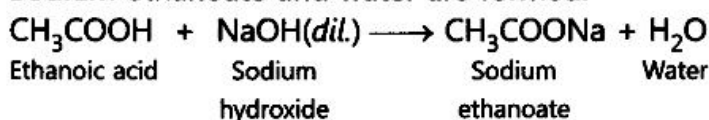

48. Describe two examples of different oxidations of ethanol. Name the products obtained in each case.

Answer.

(i) When ethanol is heated with copper at 573 K, ethanal is formed.

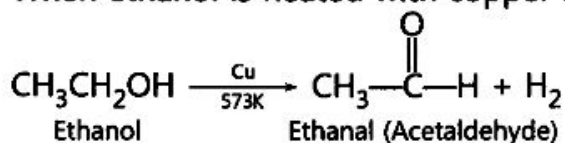

(ii) When ethanol is oxidised with alkaline potassium permanganate solution, ethanoic acid is formed.

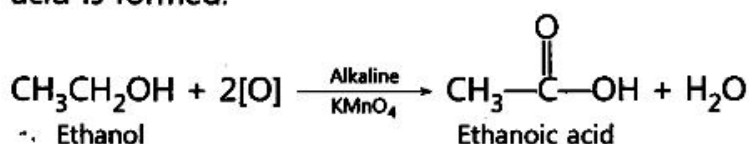

49. What are isomers? Draw the structures of two isomers of butane, C₄H₁₀. Why can't we have isomers of first three members of alkane series?

Answer. Those compounds, which have same molecular formula but different structural formulae are called isomers.

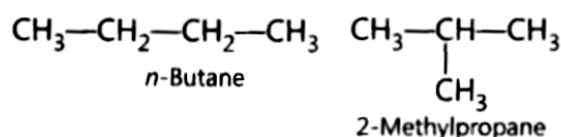

In first three members of alkane series, branching is not possible. Therefore, we cannot have isomers.

50. Define homologous series of organic compounds. List its two characteristics. Write the name and formula of the first member of the series of alkenes.

Answer. The series of organic compounds having same functional group and similar chemical properties is called homologous series.

Each member differs from successive member by —CH₂— group. The difference in molecular weight between two successive members is 14 u.

Characteristics:

(i) It has same general formula, from which, all members can be derived.

(ii) They have similar chemical properties.

C_2H_4 , $CH_2=CH_2$, Ethene is first member of alkene series.

51. **Complete the following equations:**

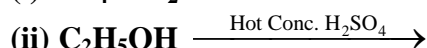
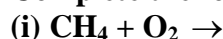

Answer.

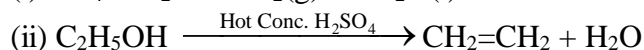

52. **Why homologous series of carbon compounds are so called? Write chemical formula of two consecutive members of a homologous series and state the part of these compounds that determines their**

(i) physical properties, and (ii) chemical properties.

Answer. The series consists of members of same family with similar physical and chemical properties, therefore, called homologous series

(i) CH_3OH , and (ii) CH_3CH_2OH are two consecutive members of homologous series.

Alkyl group $-CH_3$ and $-CH_3CH_2$ part determines physical properties. Functional group $-OH$ determines chemical properties of the compounds.

53. **Name the oxidising agent used for the conversion of ethanol to ethanoic acid. Distinguish between ethanol and ethanoic acid on the basis of (i) litmus test, (ii) reaction with sodium hydrogencarbonate.**

Answer. Alkaline potassium permanganate or Acidified potassium dichromate.

(i) Ethanol will not affect litmus paper. Ethanoic acid will turn blue litmus ' paper red.

(ii) Ethanol will not react with sodium hydrogen carbonate. Ethanoic acid will give brisk effervescence due to colourless, odourless carbon dioxide gas.

54. **What are esters? How are they prepared? List two uses of esters.**

Answer. Esters are organic compounds ($R-COO-R'$) formed by a reaction between an alcohol ($R'-OH$) and an organic acid ($R-COOH$), i.e. carboxylic acid and usually some catalyst with water as a by-product. Esters are used to make perfumes and soap. They are also used to produce pharmaceutical products, cosmetics, plasticizers and detergents.

55. **Out of HCl and CH_3COOH , which one is a weak acid and why? Describe an activity to support your answer.**

Answer. Acetic acid (CH_3COOH) is a weaker acid because it does not dissociate completely into aqueous solution.

Activity: Add zinc metal in HCl and CH_3COOH respectively. The hydrogen gas will be evolved faster in HCl and slowly in CH_3COOH . It shows acetic acid is a weak acid.

Alternative Method: If we use pH paper, the colour of pH paper will be dark red in HCl and light red in CH_3COOH which shows HCl is strong acid and CH_3COOH is a weak acid.

56. **Describe two examples of different oxidations of ethanol. Name the products obtained in each case.**

Answer.

(i) When ethanol is heated with copper at 573K, ethanal is formed.

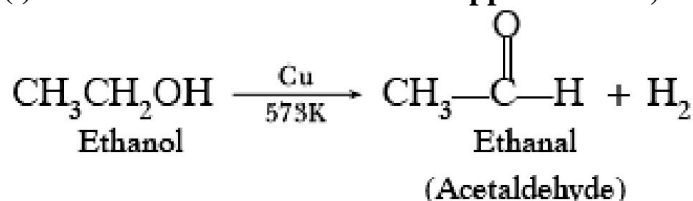

(ii) When ethanol is oxidised with alkaline potassium permanganate solution, ethanoic acid is formed.

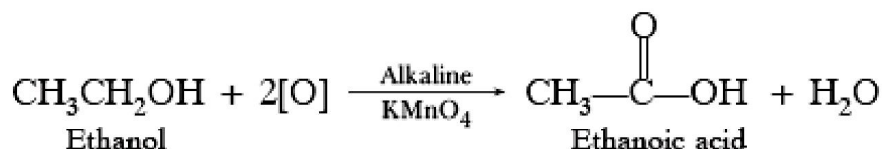

57. (a) Give chemical tests to detect the presence of (i) Ethanol (ii) Ethanoic acid

(b) Why ethanoic acid is called glacial acetic acid?

Answer. (a) Add sodium hydrogen carbonate. Ethanol will not react. Ethanoic acid will give brisk effervescence due to carbon dioxide.

(b) Pure ethanoic acid exist as solid like glaciers at 291 K, therefore, called glacial acetic acid.

58. List two tests for experimentally distinguishing between an alcohol and a carboxylic acid and describe how these tests are performed.

Answer. (i) NaHCO₃ test: Add sodium hydrogen carbonate to alcohol and a carboxylic acid separately. Alcohol will not react, whereas carboxylic acid will give brisk effervescence. Pass the gas through lime water. It will turn milky.

(ii) Blue litmus test: Add few drops of alcohol and solution of carboxylic acid on blue litmus paper separately. Blue litmus will remain as it is in case of alcohol, whereas it will turn red in carboxylic acid.

59. Distinguish between esterification and saponification reactions of organic compounds with the help of the chemical equation for each. What is the use of (i) esters and (ii) saponification process?

Answer.

Esterification: It is a process in which alcohol and carboxylic acid combine in the presence of conc. H₂SO₄ to form ester.

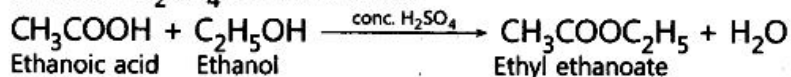

Saponification: When an ester reacts with sodium hydroxide, sodium salt of acid and alcohol is formed.

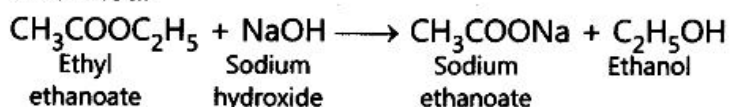

Uses:

(i) Esters are used in cold drinks, ice creams, perfumes and as artificial flavouring agents.

(ii) Saponification process is used in the manufacture of soaps.

LONG ANSWER TYPE QUESTIONS [5 Marks]

60. (a) State two properties of carbon which lead to a very large number of carbon compounds.

(b) Why does micelle formation take place when soap is added to water? Why are micelles not formed when soap is added to ethanol?

Answer.

(a) (i)-Catenation (ii) Tetravalency

(b) It is because large number of molecular ions of soaps get aggregated and form colloidal solution. Soap has hydrophobic tail (hydrocarbon) which dissolves in hydrocarbon part and hydrophilic part dissolves in water. Ethanol is non-polar solvent therefore micelles are not formed because hydrocarbon part gets attracted towards ethanol and ionic end will not dissolve in alcohol.

61. (a) In tabular form, differentiate between ethanol and ethanoic acid under the following heads:

(i) Physical state (ii) Taste

(iii) NaHCO_3 test (iv) Ester test

(b) Write a chemical reaction to show the dehydration of ethanol.

Answer.

(a)

Properties	Ethanol	Ethanoic acid
(i) Physical state	It is liquid with specific smell.	It is also liquid with vinegar like smell.
(ii) Taste	It has burning taste.	It has sour taste.
(iii) NaHCO_3 test	It does not react.	It gives brisk effervescence due to CO_2 .
(iv) Ester test	Add acetic acid and conc. H_2SO_4 , pleasant fruity smelling compound, ester is formed.	Add ethyl alcohol and conc. H_2SO_4 , pleasant fruity smelling compound, ester is formed.

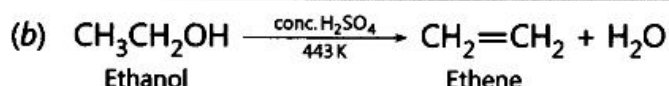

62. Explain isomerism. State any four characteristics of isomers. Draw the structures of possible isomers of butane, C_4H_{10}

Answer. Isomerism is a phenomenon due to which some compounds have same molecular formula but different structural formulae.

Characteristics:

- (i) They differ in structural formula.
- (ii) They differ in melting point.
- (iii) They differ in boiling point.
- (iv) They differ in solubility in same solvent.

There are two isomers of butane, C_4H_{10} .

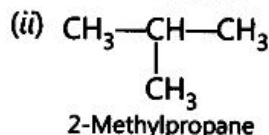
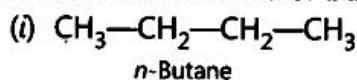

63. Give reasons for the following:

- (i) Element carbon forms compounds mainly by covalent bonding.
- (ii) Diamond has a high melting point.
- (iii) Graphite is a good conductor of electricity.
- (iv) Acetylene burns with a sooty flame.
- (v) Kerosene does not decolourise bromine water while cooking oils do.

Answer.

- (i) It is because carbon has four valence electrons, it cannot gain or lose four electrons because high energy is needed. It can only share four electrons.
- (ii) It is due to strong covalent bonds and compact structure of diamond.
- (iii) It is due to presence of free electrons in graphite because each carbon is linked to three more carbon atoms.
- (iv) It is due to high percentage of carbon, it burns with sooty or smoky flame.
- (v) Kerosene oil is mixture of saturated hydrocarbons therefore does not decolourise bromine water.

64. What is the difference between the chemical composition of soaps and detergents? State in brief the action of soaps in removing an oily spot from a shirt. Why are soaps not considered suitable for washing where water is hard?

Answer. Soaps are sodium or potassium salts of fatty acids having $-\text{COONa}$ group. Detergents are sodium or potassium salts of sulphonic acids having $-\text{SO}_3\text{Na}$ and $-\text{SO}_4\text{Na}$ group.

Cleansing action of soap: Soap molecules consist of a large hydrocarbon tail which is

hydrophobic (water-hating or water repelling) with a negatively charged head which is hydrophilic (water-loving) as shown in figure.

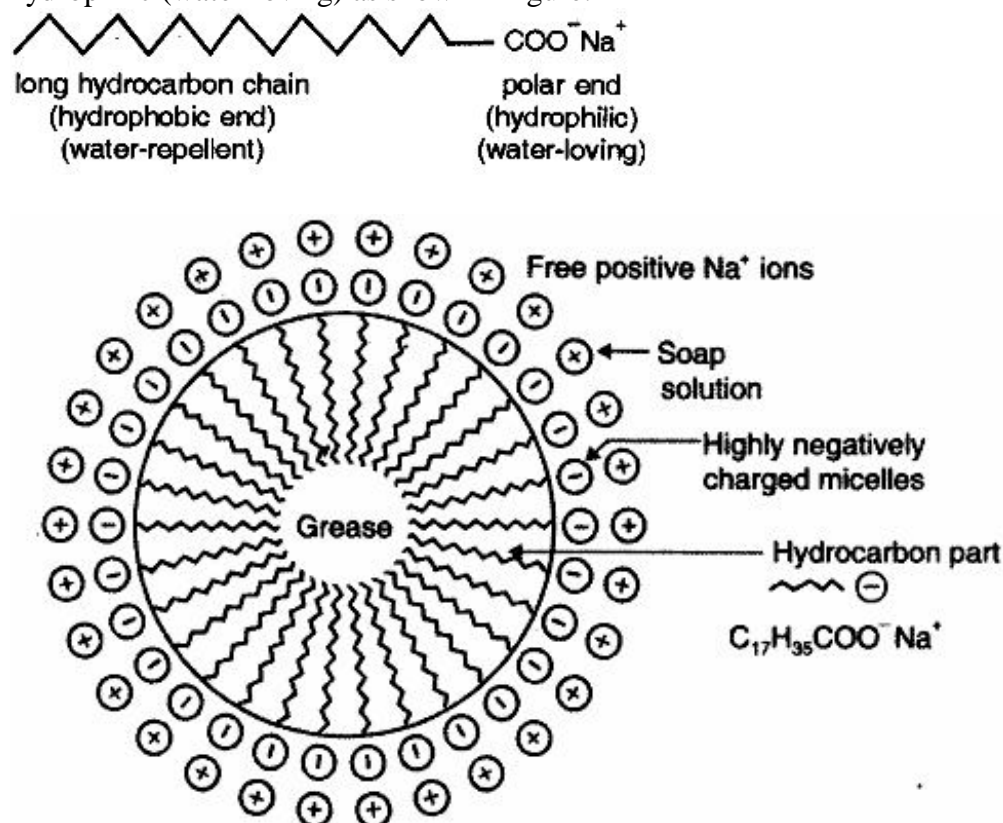

When a soap is dissolved in water, the molecules associate together as clusters called micelles in which water molecules, being polar in nature, surround the ions and the hydrocarbon part of the molecule attracts grease, oil and dirt.

The tails stick inwards and the heads outwards. In cleaning, the hydrocarbon tail attaches itself to oily dirt. When water is agitated (shaken vigorously), the oily dirt tends to lift off from the dirty surface and dissociate into fragments.

This gives opportunity to other tails to stick to oil. The solution now contains small globules of oil surrounded by soap molecules.

The negatively charged and form aggregates. Thus, the oily dirt is removed. Hard water has Ca^{2+} and Mg^{2+} ions. When it reacts with soap, it forms insoluble compound and the soap goes waste.

65. List in tabular form three physical and two chemical properties on the basis of which ethanol and ethanoic acid can be differentiated

Answer.

Physical properties:

Ethanol	Ethanoic acid
1. It has specific smell.	1. It has vinegar like smell.
2. It has burning taste.	2. It is sour in taste.
3. It does not freeze in winters.	3. It freezes in winters.

Chemical properties:

Ethanol	Ethanoic acid
1. It does not react with NaHCO_3 .	1. It gives CO_2 with NaHCO_3 .
2. It burns with blue flame.	2. It does not burn with blue flame.
3. It does not affect blue litmus.	3. It turns blue litmus red.

66. What are the hydrocarbons write the name and general formula of (i) saturated hydrocarbons, (ii) unsaturated hydrocarbons, and draw the structure of one hydrocarbon of each type. How can an unsaturated hydrocarbon be made saturated?

Answer.

- (i) Alkanes, C_nH_{2n+2} are saturated hydrocarbons.

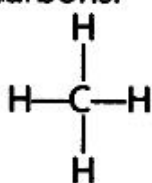

Methane
(Saturated hydrocarbon)

- (ii) Alkenes, C_nH_{2n} and Alkynes, C_nH_{2n-2} are unsaturated hydrocarbons.

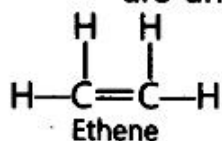

Ethene
(Unsaturated hydrocarbon)



Ethyne
(Unsaturated hydrocarbon)

Unsaturated hydrocarbons can be made saturated by hydrogenation.

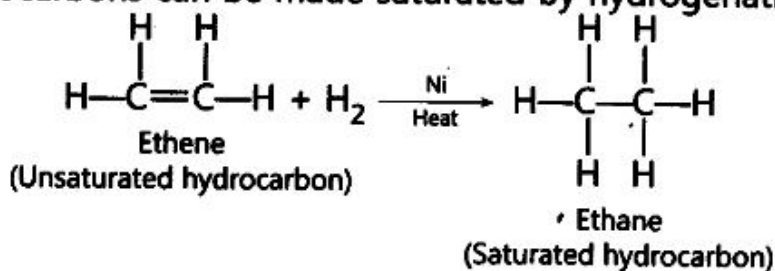

67. What are detergents chemically? List two merits and two demerits of using detergents for cleansing. State the reason for the suitability of detergents for washing, even in the case of water having calcium and magnesium ions.

Answer. Detergents chemically are sodium or potassium salts of sulphonic acid of benzene or alkene.

Merits:

- (i) They work well with hard water.
- (ii) They are more effective than soaps.

Demerits:

- (i) They are expensive.
 - (ii) Some of them having branching are non-biodegradable, therefore create water pollution.
- Detergents are suitable for hard water having Mg^{2+} and Ca^{2+} ions because they do not form insoluble salts with Mg^{2+} and Ca^{2+} ions.

68. What are micelles? Why does it form when soap is added to water? Will a micelle be formed in other solvents such as ethanol also? State briefly how the formation of micelles help to clean the clothes having oily spots.

Answer. Micelles: When molecular ions in soaps and detergents aggregate, they form micelles. It is formed because soap has hydrophobic part. Water can attract hydrophilic part but not hydrophobic part.

No, micelle will not be formed in ethanol, as soap will dissolve in ethanol. Micelles trap (attract) dirt, grease, oily spot, etc. which is washed away by water.

69. (a) **What is a soap? Why are soaps not suitable for washing clothes when the water is hard?**

(b) **Explain the action of soap in removing an oily spot from a piece of cloth.**

Answer. (a) Soap is sodium or potassium salt of higher fatty acids such as oleic acid ($C_{17}H_{33}COOH$), stearic acid ($C_{17}H_{35}COOH$), palmitic acid ($C_{15}H_{31}COOH$), etc.

A soap is a sodium or potassium salt of long chain fatty acids. Hard water contains salts of calcium and magnesium. On adding soap to water, calcium and magnesium ions present in water displace sodium or potassium ions from the soap molecules forming an insoluble substance called scum. Scum results in wastage of soap.

(b) **Cleansing action of soaps:**

The oily spot present on clothes is organic in nature and insoluble in water. Therefore, it cannot be removed by only washing with water. When soap is dissolved in water, its hydrophobic ends attach themselves to the oily spot and remove it from the cloth. Then, the molecules of soap arrange themselves in the form of micelle and trap the dirt at the centre of the cluster. These micelles remain suspended in the water. Hence, the oily spots are easily rinsed away by water.

70. **A carbon compound X turns blue litmus to red and has a molecular formula $C_2H_4O_2$. Identify X and draw its structure. Write chemical equation for the reaction and name of the product formed in each case when X reacts with**

(a) **ethanol in the presence of conc. H_2SO_4**

(b) **sodium carbonate.**

Answer. 'X' is ethanoic acid.

Its structure is $CH_3-\overset{\overset{O}{\parallel}}{C}-OH$

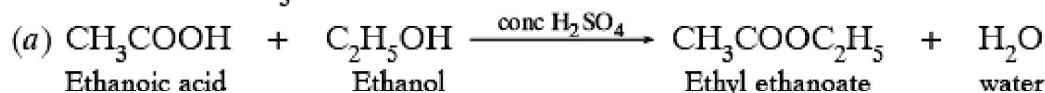

LIFE PROCESSES

VERY SHORT ANSWER TYPE QUESTION [1 MARK]

1. **What will happen to a plant if its xylem is removed?**

Answer. Xylem in plant transports water and dissolved mineral nutrients from the roots to all parts of the vascular plant. So, if xylem is removed from the plant, the water and mineral supply to the plant will stop and therefore, the plant will die.

2. **Where does digestion of fat take place in our body?**

Answer. Digestion of fat takes place in the small intestine of our body.

3. **Name one accessory pigment and one essential pigment in photosynthetic plants.**

Answer. Accessory pigment – Carotene/Xanthophyll
Essential pigment – Chlorophyll

4. **What is the mode of nutrition in human beings?**

Answer. Holozoic nutrition.

5. **Mention the raw materials required for photosynthesis.**

Answer. The following raw materials are required for photosynthesis:

(i) Carbon Dioxide: Plants get CO₂ from atmosphere through stomata.

(ii) Water: Plants absorb water from soil through roots and transport to leaves.

(iii) Sunlight: Sunlight, which is absorbed by the chlorophyll and other green parts of the plant.

6. **What would be the consequences of deficiency of hemoglobin in your body?**

Answer. The deficiency of hemoglobin in our body is called anemia. In anemia, the blood is unable to carry the sufficient amount of oxygen required by the body. So, respiration would be less and less energy will be available to the body. The hemoglobin deficient person will feel weak, pale, lethargic and will be unable to perform heavy physical work.

7. **Name the green dot like structures in some cells observed by a student when a leaf peel was viewed under a microscope. What is this green colour due to?**

Answer. The green dot-like structures in some cells observed by a student when a leaf peel is viewed under a microscope are chloroplasts. The green colour is due to the presence of green pigment, chlorophyll.

8. **State any one difference between autotrophic and heterotrophic modes of nutrition.**

Answer. In autotrophic nutrition, organisms obtain their food from inorganic substances. In heterotrophic nutrition, organisms derive their food from organic substances.

9. **Give one reason why multicellular organisms require special organs for exchange of gases between their body and their environment. :**

Answer. In unicellular organisms the entire body of the organism is in contact with the environment hence exchange of materials can take place but, in multicellular organisms the entire body of the organism is not in contact with the environment and hence simple diffusion is not helpful.

10. **Name the process in plants where water is lost as water vapour. :**

Answer. Transpiration is the process when plants lose water as vapour.

11. **What is 'translocation' in plants?**

Answer. Translocation is the movement of soluble materials, products of photosynthesis from leaves to other tissues throughout the plant.

12. **State the basic difference between the process of respiration and photosynthesis.**

Answer. Respiration uses O₂ and releases CO₂ but in photosynthesis, CO₂ is used and O₂ is released.

13. **Name the intermediate and the end products of glucose breakdown in aerobic respiration.**

Answer.

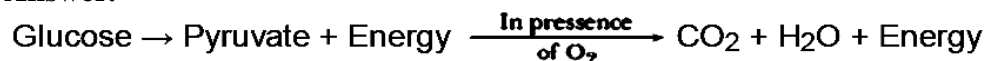

14. **Mention two structural features of small intestine which add to the absorptive capacity.**

Answer. Two structural features of small intestine are:

- (i) Villi is present to increase the absorptive surface area.
- (ii) Lacteals in the villi receive the products of fat digestion.

15. **In the experiment “Light is essential for photosynthesis”, why does the uncovered part of the leaf turn blue-black after putting iodine solution?**

Answer. Starch is produced in the uncovered part of the leaf because it is exposed to sunlight allowing it to photosynthesize, which turns blue-black in presence of iodine solution.

16. **Name the component of blood that helps in the formation of blood clot in the event of a cut.**

Answer. Platelets help in clotting of blood in the event of a cut.

17. **Mention how organisms like bread moulds and mushrooms obtain their food.**

Answer. Organisms like bread moulds and mushrooms breakdown the food materials outside the body and then absorb the nutrients of the bread.

18. **What advantage over an aquatic organism does a terrestrial organism have with regard to obtaining oxygen for respiration?**

Answer. The amount of oxygen dissolved in water is very low, as compared to amount of oxygen in air. Thus, terrestrial organism has to make less efforts to obtain oxygen than an aquatic organism to obtain oxygen for respiration.

19. **Name the two ways in which glucose is oxidised to provide energy in various organisms.**

Answer. The two ways in which glucose is oxidised to provide energy in various organisms are aerobic respiration pathway which uses oxygen to break-down glucose completely into carbon dioxide and water and some use other pathways that do not involve oxygen which is called anaerobic respiration pathway.

20. **Specify two conditions in which photo-respiration may take place in green plants.**

Answer. Two conditions in which photorespiration may take place in green plants are: (i) High concentration of oxygen and (ii) High temperature

SHORT ANSWER TYPE QUESTIONS[I] [2 MARKS]

21. **What are the final products after digestion of carbohydrates and proteins?**

Answer. The final product produced after digestion of carbohydrates is glucose and of proteins is amino acids.

22. **What is saliva? State its role in the digestion of food.**

Answer. Saliva is a watery fluid secreted by the salivary glands in the mouth. The digestive functions of saliva include moistening food, and helping to create a food bolus, so it can be swallowed easily. Saliva contains the enzyme amylase that breaks some starches down into maltose and dextrin.

23. **Explain the process of nutrition in Amoeba.**

Answer. The mode of nutrition in Amoeba is holozoic. It feeds on unicellular plant or animal. The various steps of nutrition are ingestion, digestion, assimilation and egestion. When Amoeba comes in contact with food particles, it sends out pseudopodia, which engulfs the prey by forming a food cup, which is known as ingestion. When the tips of the encircling pseudopodia touch each other, the food is encaptured into a bag called food vacuole. The food vacuole serves as a temporary stomach secreting digestive juice, this step is known as digestion. The digested food gets absorbed and diffuses into the cytoplasm and then assimilated. Egestion of undigested food takes place at any point on the surface of the body.

24. **State two differences between arteries and veins.**

Answer. Arteries: Arteries carry oxygenated blood, away from the heart except pulmonary artery. These are thick-walled, highly muscular except arteries of cranium and vertebral column. Valves are absent. Blood in arteries moves with pressure.

Veins: Veins carry deoxygenated blood, towards the heart except pulmonary veins. These are thin-walled. Valves are present which provide unidirectional flow of blood.

Blood in veins moves under very low pressure.

25. **How are the alveoli designed to maximise the exchange of gases?**
Answer. Alveoli are small pouches or sacs like structure. They are surrounded by blood capillaries. Thus a large amount of air is brought in contact with the air in the lungs. More than millions of alveoli are present in the lungs. The presence of millions of alveoli in the lungs provides a very large surface area for the exchange of gases. The availability of large surface area maximises the exchange of gases.
26. **Explain the mechanism of gaseous exchange between tissues and blood.**
Answer. Exchange of respiratory gases, i.e. oxygen and carbon dioxide occurs between the blood and tissues.
 In tissues, oxygen is used up for their activities and carbon dioxide is released. The blood from lungs has high concentration of oxygen and low concentration of carbon dioxide. Due to this, difference in concentration of oxygen and carbon dioxide, the exchange of gases takes place between tissue and blood.
27. **Describe the mechanism of blood clotting.**
Answer. Blood Clotting: It is the mechanism that prevents the loss of blood at the site of an injury or wound by forming a 'blood clot'. The blood has platelet cells which circulate around the body and plug these leaks by helping to clot the blood at these points of injury to prevent it from excessive bleeding.
28. **Why are white blood corpuscles called 'soldiers' of the body?**
Answer. White blood corpuscles can fight with the disease germs present in the body carried by blood and help to maintain a healthy body. So, they are called as 'soldiers' of the body.
29. **Which part of the human heart is considered as pace-maker? Why is it so called?**
Answer. Sino-atrial node of the human heart is considered as pacemaker. Sino-atrial node is also called as pacemaker because it determines the rate of heartbeat by determining the rate of discharge of cardiac impulse.
30. **Which enzyme initiates the digestion of proteins ? Name the other enzyme produced by the same gland.**
Answer. The enzyme gastric pepsin initiates the digestion of proteins. The other enzyme produced by the stomach is gastric lipase.
31. **Name the first digestive organ that is associated with the breakdown of proteins in humans. What are its three releases?**
Answer. The first digestive organ in humans is the stomach. It releases proteolytic enzymes, HCl and mucus.
32. **Name two excretory products other than O₂ and CO₂ in plants.**
Answer. The two excretory products other than O₂ and CO₂ in plants are resins and gums.
33. **Why do the walls of the trachea not collapse when there is less air in it?**
Answer. Rings of cartilages are present in trachea. These rings support the trachea and do not allow the trachea to collapse when there is less air in it.
34. **What are enzymes? Name any one enzyme of our digestive system and write its function.**
Answer. Enzymes are biological catalysts. Catalysts are proteins that increase the rate of chemical reactions without being used up. For example: Amylase catalyses the breakdown of starch into sugars in the mouth and small intestine
35. (i) **Write the balanced chemical equation for the process of photosynthesis,**
 (ii) **When do the desert plants take up carbon dioxide and perform photosynthesis ?**
Answer.
 (i) Photosynthesis can be represented using a chemical equation. The overall balanced equation is

$$6\text{CO}_2 + 12\text{H}_2\text{O} \xrightarrow{\text{Sunlight energy}} \text{C}_6\text{H}_{12}\text{O}_6 + 6\text{H}_2\text{O} + 6\text{O}_2$$

 (ii) Desert plants open up their stomata during night and take in CO₂. Stomata remains close during the day time to prevent the loss of water by i transpiration. They store the CO₂ in their cells until the sun comes out and they can carry on with photosynthesis during the day time.

36. **Why there is no mixing of deoxygenated and oxygenated blood in the human heart normally?**

Answer. There is no mixing of deoxygenated and oxygenated bloods in human heart due to the presence of inter-ventricular septum. This septa completely divides the ventricle into right and left to avoid mixing of blood.

37. **Why are the walls of ventricles thicker than the auricles ?**

Answer. The walls of ventricles are thicker than the auricles because ventricles have to pump the blood to all the parts of the body during their contraction. To counteract the backward pressure exerted by the blood, the walls of the ventricles have to be thicker otherwise it may lead to bursting of heart.

38. **Why do herbivores have longer, small intestine than carnivores ?**

Answer. Digestion of cellulose takes a longer time. Hence, herbivores eating grass need a longer small intestine to allow complete digestion of cellulose. Carnivorous animals cannot digest cellulose due to the absence of enzyme CELLULASE, hence they have a shorter intestine.

39. **Write any two functions of large intestine in man.**

Answer. Functions of large intestine in man are: (i) It serves to store the unabsorbed food remnants temporarily. (ii) It concentrates the contents by absorbing water. (iii) The movements of colon help to void the faeces through anus.

40. **How would digestion of food be affected if the bile duct is completely blocked? Explain.**

Answer. If the bile duct is completely blocked, bile juice will not reach the small intestine and the digestion of fats will be affected.

41. **How would it affect the digestion of proteins and carbohydrates in the duodenum of man if there is a blockage in the pancreatic duct? Explain.**

Answer. If there is a blockage in the pancreatic duct, the pancreatic juice which contains enzymes for the digestion of carbohydrates and proteins will not reach the small intestine.

42. **How is carbon dioxide obtained by (a) aquatic plants and (b) terrestrial plants ?**

Answer. (a) Aquatic plants take up carbon dioxide dissolved in water.

(b) Terrestrial plants use carbon dioxide present in air.

43. **Draw a neat labelled diagram of the structure of a chloroplast.**

Answer.

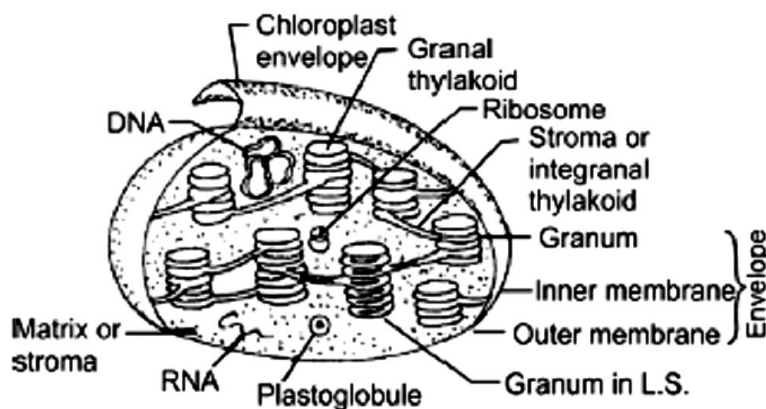

Structure of Chloroplast

44. **Write correct sequence of four steps of method for the preparation of temporary mount of a stained leaf peel.**

Answer.

→ Take a healthy leaf from the potted plant.

→ Remove a part of the peel from the lower surface of the leaf. You can do this by folding the leaf over and gently pulling the peel apart using forceps. Keep the peel in a watch glass containing water.

→ Put a few drops of safranin stain in a watch glass.

- After 2-3 minutes take out the peel and place it on a clean glass slide.
- Put a drop of glycerin over the peel and place a clean coverslip gently over it with the help of a needle.
- Remove the excess stain and glycerin with the help of blotting paper.
- Observe the slide under magnifications of the compound microscope.

SHORT ANSWER TYPE QUESTIONS[II] [3 MARKS]

45. **In single celled organisms diffusion is sufficient to meet all their requirements of food, exchange of gases or removal of wastes but it is not in case of multicellular organisms. Explain the reason for this difference.**

Answer. Unicellular organisms can absorb sufficient oxygen because of its complete contact with the atmosphere, but in multicellular organisms the rate of absorption and diffusion becomes very less because all cells are not in direct contact with the atmosphere. Multicellular organisms require greater amount of oxygen to sustain life processes which cannot be fulfilled by the process of diffusion.

46. **Draw a diagram of human excretory system and label kidneys, ureters on it.**

Answer.

Excretory System

- Removal of waste from the body

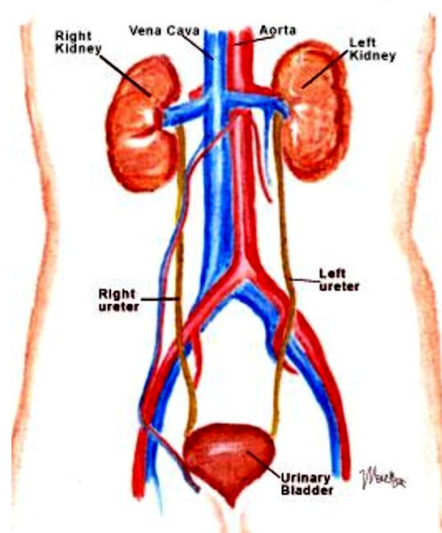

47. **Name the acid presents in the following:**

(i) Tomato (ii) Vinegar (iii) Tamarind

Answer.

(i) Oxalic acid (ii) citric acid (iii) Tartaric acid.

48. **State the role of the following in human digestive system :**

(i) Digestive enzymes (ii) Hydrochloric acid (iii) Villi

Answer.

(i) Digestive enzymes – Foods need to be broken into their small or simpler molecules so that they can be absorbed into the bloodstream. However, the physical breakdown of food is not enough. Enzymes are hence needed for the chemical breakdown of food and speeding up the digestive process. The products of digestion can hence be small enough to be absorbed.

(ii) Hydrochloric acid – Hydro chloric acid helps to kill the germs which might have entered in to the system through food. It creates acidic medium for the pepsin to act on food to breakdown proteins.

(iii) Villi – Villi are finger like projections in the small intestine. They help to increase the surface area for absorption of the digested food. Villi are richly supplied with blood vessel which help to absorb digested food in to the blood stream.

49. **11. In mammals and birds why is it necessary to separate oxygenated and de-oxygenated blood ?**

Answer. Mammals and birds are warm blooded animals. This means they can control their body temperature and do not have to depend on environment for their body temperature regulation. Because of this birds and mammals require optimum oxidization of glucose which would be possible with good supply of oxygen. So it is required to have separate oxygenated and de-oxygenated blood to supply the required amount of oxygen.

50. **Draw a neat diagram of excretory system of human beings and label on it:**

(i) Left kidney (ii) Urinary bladder

Answer.

Refer Q. No. 46

51. **Draw a diagram of human respiratory system and label on it :**

(i) Diaphragm (ii) Larynx

Answer.

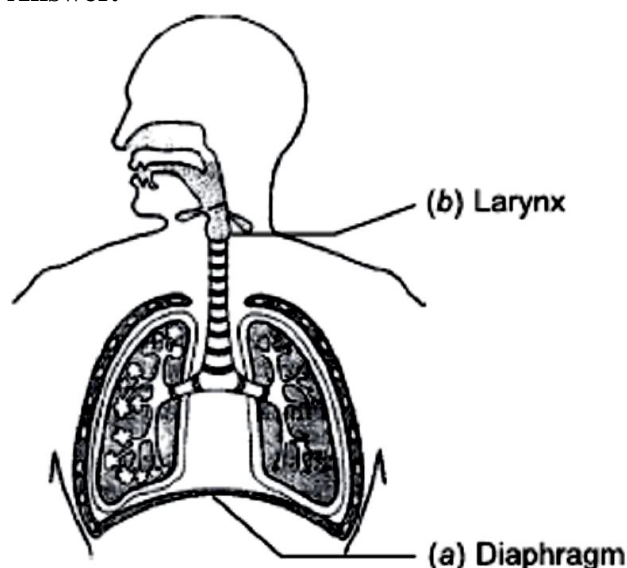

52. **List three characteristics of lungs which make it an efficient respiratory surface.**

Answer. These features which particularly make our lungs efficient for gas exchange.

1.Thin: the air sac walls are very thin so that gases can quickly diffuse through them. Oxygen is absorbed in to the blood and carbon dioxide is given out in to the lungs to be exhaled out.

2.Moist: the air sacs are moist with mucus so that gases can dissolve before diffusing.

3.Large surface area: the surface area for gases to diffuse through in human lungs is roughly the same as a tennis court. The alveoli help to increase the surface area for absorption of oxygen.

4.Good blood supply: the air sacs or the alveoli have a large capillary network so that large volumes of gases can be exchanged. More the flow of blood more exchange.

53. **(a) What is the role of HCl in our stomach ?**

(b) What is emulsification of fats ?

(c) Which protein digesting enzyme is present in pancreatic juice ?

Answer.

(a)(i) It sterilises food by killing pathogens and other microbes.

(ii) It has a pH of 2, which is perfect for entyaus such as pepsin to break down proteins as effectively as possible.

(iii) Helps emulsify food (digestion of protein and stimulates the pancreas to produce digestive enzymes and bile) and protects against harmful ' bacteria

(b) Breakdown of large gloubule fats into smaller fats droplets is known as emulsification.

(c) Trypsin is the enzyme secreted by the pancreas which aids in digestion of proteins.

54. (a) Name the site of exchange of material between the blood and surrounding cells. (b) Draw a schematic representation of transport and exchange of oxygen and carbon dioxide in human body.

Answer.

(a) Capillaries

(b)

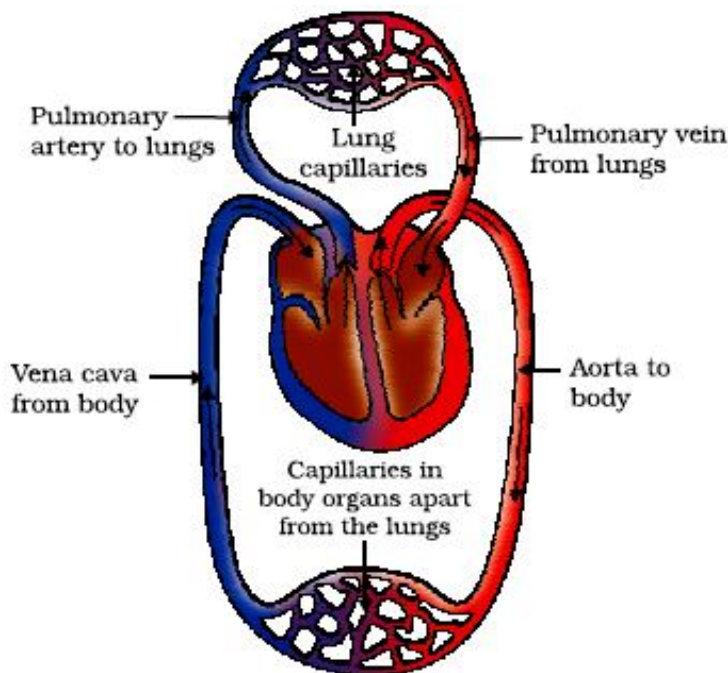

55. List in tabular form three differences between arteries and veins.

Answer.

Arteries	Veins
(i) Arteries carry oxygenated blood, away from the heart except pulmonary artery.	(i) Veins carry deoxygenated blood, towards the heart except pulmonary veins.
(ii) These are mostly deeply situated in the body.	(ii) These are superficial and deep in location.
(iii) These are thick-walled, highly muscular except arteries of cranium and vertebral column.	(iii) These are thin-walled.

56. In human alimentary canal, name the site of complete digestion of various components of food. Explain the process of digestion.

Answer. In small intestine, complete digestion of various components of food take place. The process of digestion of food in mouth, stomach and small intestine in human body are as follows:

Mouth: Digestion of food begins in the mouth. Saliva present in mouth contains a digestive enzyme, called salivary amylase, maltose and dextrins, which breaks down starch into sugar.

Stomach: Stomach stores and mixes the food received from the oesophagus with gastric juices. The main components of gastric juice are hydrochloric acid, mucus and pepsinogen. Hydrochloric acid dissolves bits of food and creates an acidic medium. In this medium, pepsinogen is converted to pepsin which is a protein-digesting enzyme. Mucus protects the inner lining of the stomach from the action of HCl.

Small Intestine: Small intestine is the site of complete digestion of carbohydrates, proteins and fats. Small intestine produces intestinal juice from the glands present in its wall. The intestinal juice helps in further digestion of food. Small intestine also obtains digestive juices from liver and

pancreas. The liver produces bile juice that causes emulsification of fats and the pancreas produces pancreatic juice for digesting proteins and emulsified fats. This digested food is finally absorbed through the intestinal walls.

57. **List the three kinds of blood vessels of human circulatory system and write their functions in tabular form.**

Answer. Three types of blood vessels in human circulatory system are: Arteries, Veins and Capillaries.

Their functions are tabulated below:

Arteries	Veins	Capillaries
(i) Arteries carry oxygenated blood from heart to various organs of the body. (ii) They are thick walled.	(i) Veins carry deoxygenated blood from various organs to heart. (ii) They are thin walled.	(i) Exchanges of materials between blood and surrounding cells take place in the capillaries. (ii) They are thin walled and extremely narrow tubes or blood vessels which connect arteries to veins.

58. (a) “The breathing cycle is rhythmic whereas exchange of gases is a continuous process”. Justify this statement.

(b) What happens if conducting tubes of circulatory system develops a leak? State in brief, how could this be avoided?

(c) How opening and closing of stomata takes place?

Answer. (a) The breathing cycle involves inhalation and exhalation of air due to alternate expansion and contraction of thoracic cavity. Thus it is a rhythmic process. But exchange of gases is a continuous process as it takes place between the blood and each and every cell, by diffusion.

(b) The circulatory system will become inefficient if it develops a leak. This could be avoided by maintaining a normal blood pressure.

(c) When water flows into the guard cells, the guard cells swell and the stomatal pore opens up. When water moves out the guard cells shrinks and the stomatal pore closes.

59. **Describe in brief the function of kidneys, ureters, urinary bladder and urethra.**

Answer. The Kidneys filter the blood and concentrate the filtrate to make urine. They also help regulate blood pressure.

Ureters transport the urine to the urinary bladder.

Urinary bladder is like a holding tank for the urine until it's ready to be excreted. Urethra is the tube that connects the urinary bladder to the outside of the body for excretion.

60. **Explain the process of breakdown of glucose in a cell (ii) in the absence of oxygen.**

Answer. The process of breakdown of glucose in a cell are as follows:

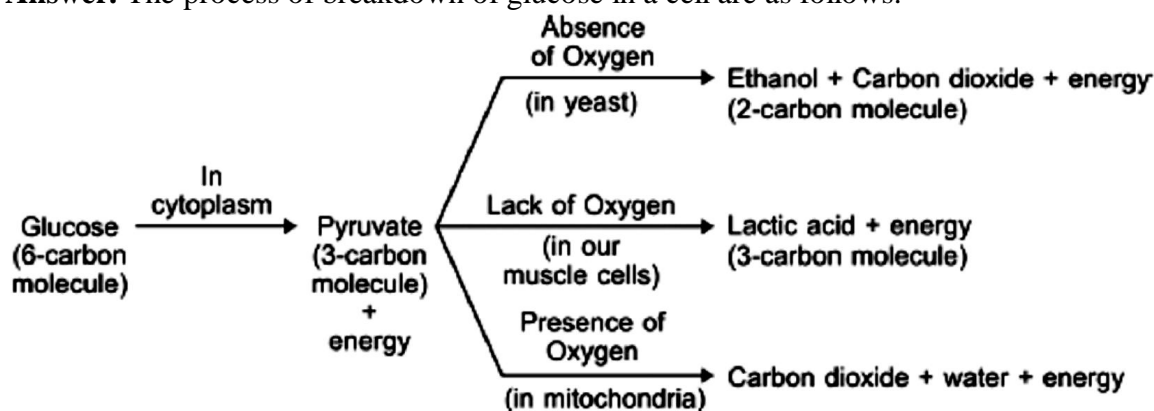

The first step in the breakdown of glucose both in presence of O_2 and in absence of O_2 is same. In this step, glucose is broken down into pyruvate.

Second step which involves further breakdown of private into simple compounds can take place in two different ways:

(a) In presence of O_2 : In the presence of O_2 , pyruvate is converted into CO_2 and water. Energy released during aerobic respiration is much greater than that released during an anaerobic respiration.

(b) In absence of O_2 : In the absence of O_2 in yeast, pyruvate is converted into ethanol and CO_2 and the process is called fermentation. In absence of O_2 , in our muscle cells, pyruvate is converted into lactic acid. The build up of lactic acid in muscle cells causes cramps.

61. **Draw a diagram of the front view of human heart and label any six parts including at least two, that are concerned with arterial blood supply to the heart muscles.**

Answer.

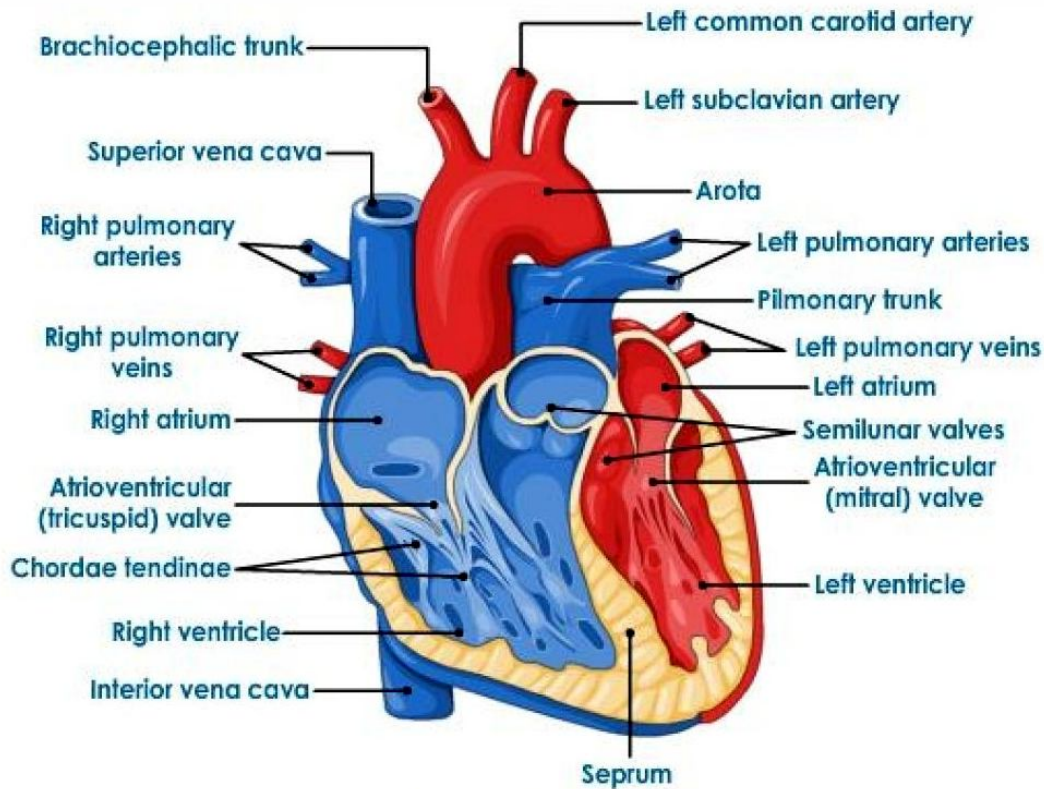

LONG ANSWER TYPE QUESTION [5 MARKS]

62. (a) **Explain how does the exchange of gases occur in plants across the surface of stems, roots and leaves.**

(b) **How are water and minerals transported in plants ?**

Answer.

(a) In plants there are tiny pores called stomata on leaves and lenticels in stem which facilitate the exchange of gases. Carbon dioxide is taken in and oxygen given out {during photosynthesis} and vice versa during respiration.

(b) Water and minerals are transported within the plant by the Xylem vessels (mainly in an upward direction); these are part of the vascular system which also includes Phloem vessels. Phloem transports the products of photosynthesis within the plant, to all parts like the stem, roots, fruits etc. in all directions.

63. **Draw a diagram of human excretory system and label renal artery and urethra.**

State in brief the function of :

1. **renal artery**
2. **kidney**
3. **ureter**
4. **urinary bladder**

Answer.

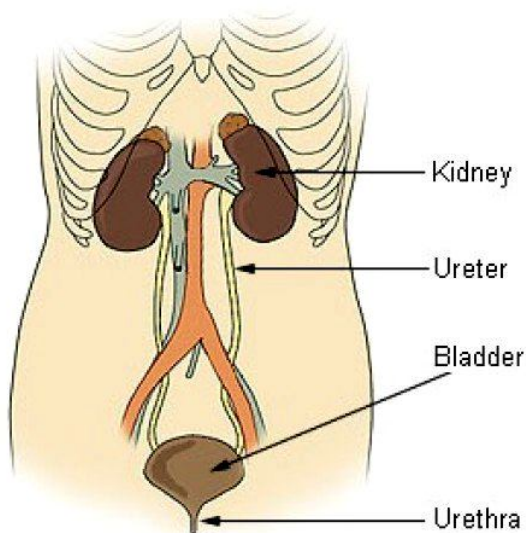

Renal artery: The renal artery carries blood to the kidneys from the abdominal aorta. This blood comes directly from the heart and is sent to the kidneys to be filtered before it passes through the rest of the body. Up to one-third of the total cardiac output per heartbeat is sent to the renal arteries to be filtered by the kidneys. Each kidney has one renal artery that supplies it with blood. The filtered blood then can exit the renal vein.

Kidney: The kidneys perform the essential function of removing waste products from the blood and regulating the water fluid levels. The kidneys regulate the body's fluid volume, mineral composition and acidity by excreting and reabsorbing water and inorganic electrolytes.

Ureter: The ureter is a tube that carries urine from the kidney to the urinary bladder. There are two ureters, one attached to each kidney.

Urinary bladder: The urinary bladder is an expandable muscular sac that stores urine before it is excreted out of the body through the urethra.

64. (a) Draw a diagram to show open stomatal pore and label on it:
(i) guard cells
(ii) chloroplast
(b) State two functions of stomata.
(c) How do guard cells regulate the opening and closing of stomatal pore?

Answer.(a)

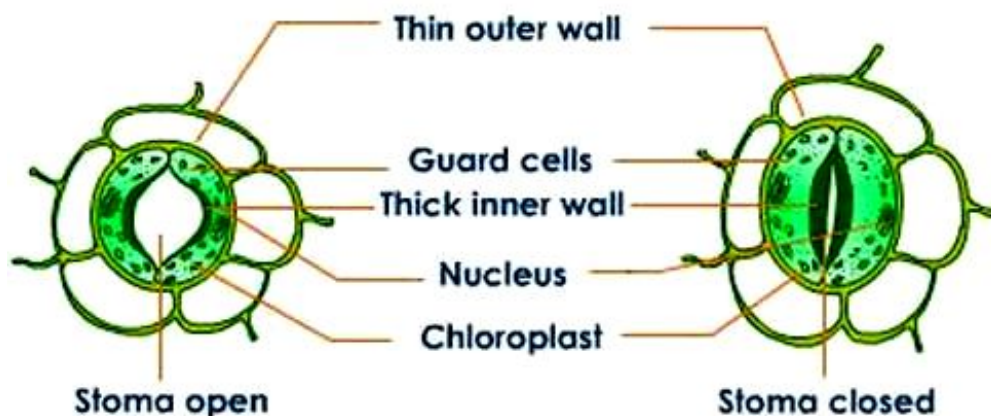

(b) Two functions of stomata are:

- (i) Exchange of gases between the plant and the atmosphere takes place through stomata.
(ii) Transpiration in plants takes place through stomata.

(c) Opening and Closing of Stomatal Pore: The opening and closing of the pore is a function of the guard cells. The guard cells swell when water flows into them causing the stomatal pore to

open. Similarly, the pore closes if the guard cells shrink. As large amount of water is lost through these stomata, the plant closes these pores when it does not require carbon dioxide for photosynthesis.

65. (a) Draw a diagram of excretory system in human beings and label the following parts. **Aorta, kidney, urinary bladder and urethra.**

(b) How is urine produced and eliminated ?

Answer.(a) Refer Figure in Q. 63

(b) Blood from the heart comes into the kidneys afferent and efferent arteriols from the renal arteries where it enters about 2-3 million nephrons per kidney. Then, it goes through the glomerulus a tuft or bunch of blood capillaries and get rid of some of the unwanted substances like urea, uric acid, creatinine in the blood and then continues through the renal tubules. The loop of Henley, reabsorb certain substances such as water (actually if body is dehydrated, body will send anti-diuretic hormone (ADH) to kidneys to prevent extra water from going into urine and thus saving water for body and get rid of anything else that isn't wanted, then the urine goes through ureters to bladder and then to urethra where it is excreted out of body as urine.

66. (a) Draw a diagram of human respiratory system and label the following:

(i) part where air is filtered by fine hair and mucus

(ii) part which terminates in balloon – like structures

(iii) balloon – like structures where exchange of gases takes place. (iv) part which separates chest cavity from abdominal cavity.

(b) Why is the rate of breathing in aquatic organisms much faster than in terrestrial organisms?

Answer.(a)

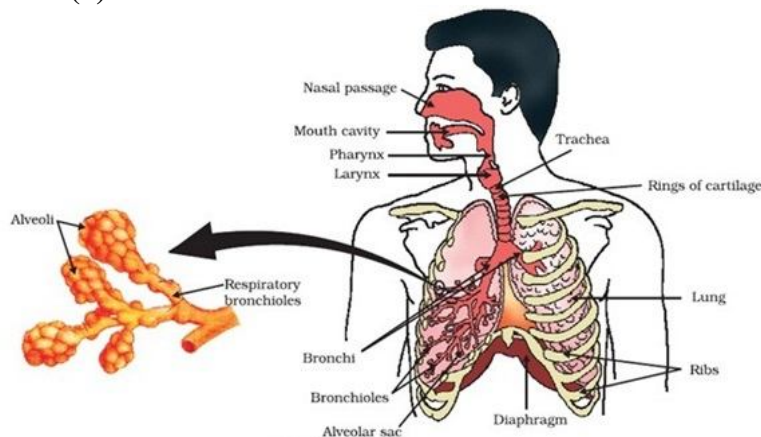

(b) Quantity of dissolved oxygen is fairly low in water as compared to the amount of oxygen in air. Aquatic organisms therefore have to breath faster than terrestrial organisms to absorb the required amount of oxygen from the water.

67. Draw a neat diagram of excretory system of human beings and label the following:

(i) Kidney

(ii) Ureter

(iii) Urinary Bladder

(iv) Urethra

Answer.

Refer Figure in Q. 63

68. (a) Draw a schematic representation of transport and exchange of oxygen and carbon dioxide during transportation of blood in human beings and label on it:

Lung capillaries, Pulmonary artery to lungs, Aorta to body, Pulmonary veins from lungs.

(b) What is the advantage of separate channels in mammals and birds for oxygenated and deoxygenated blood?

Answer.(a) A schematic representation of transportation and exchange of oxygen and carbon dioxide during transportation of blood in human beings

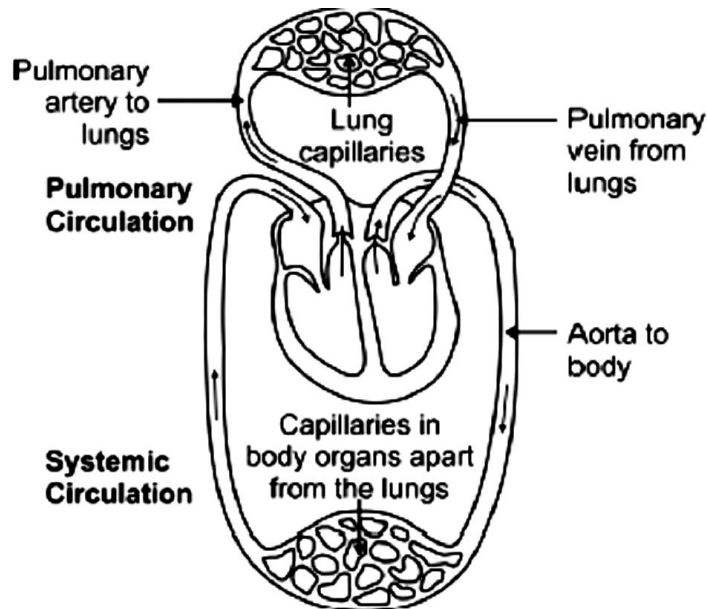

A schematic representation of transport and exchange of oxygen and carbon dioxide during transportation of blood in human beings

(b) It is necessary to separate oxygenated and deoxygenated blood in mammals and birds because they need high energy and large amount of oxygen. The separation of oxygenated and deoxygenated blood provides high oxygen supply to the organs.

69. (a) **Draw a diagram depicting Human Alimentary Canal and label on it: Gall bladder, Liver and Pancreas.**

(b) **State the roles of Liver and Pancreas.**

(c) **Name the organ which performs the following functions in humans:**

(i) **Absorption of digested food**

(ii) **Absorption of water.**

Answer.(a)

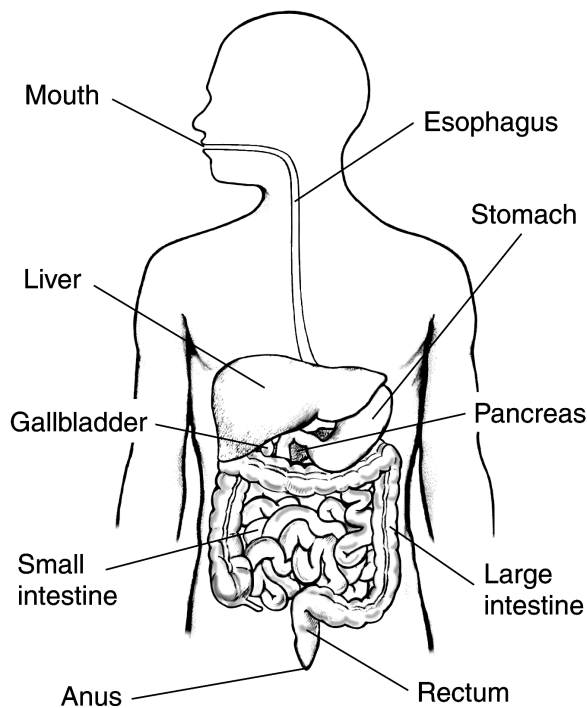

(b) **Liver:** It synthesizes and stores bile juice secreted by the gall bladder which breaks down fats into fat globules. **Pancreas:** It secretes pancreatic juice which contains protein-digesting and starch-digesting enzymes.

(c) The organs which perform the following functions in humans are as follows:

(i) Absorption of digested food – Small intestine.

(ii) Absorption of water – Large intestine.

70. (a) Draw a sectional view of the human heart and label on it – Aorta, Right ventricle and Pulmonary veins.

(b) State the functions of the following components of transport system:

(i) Blood (ii) Lymph

Answer.(a)

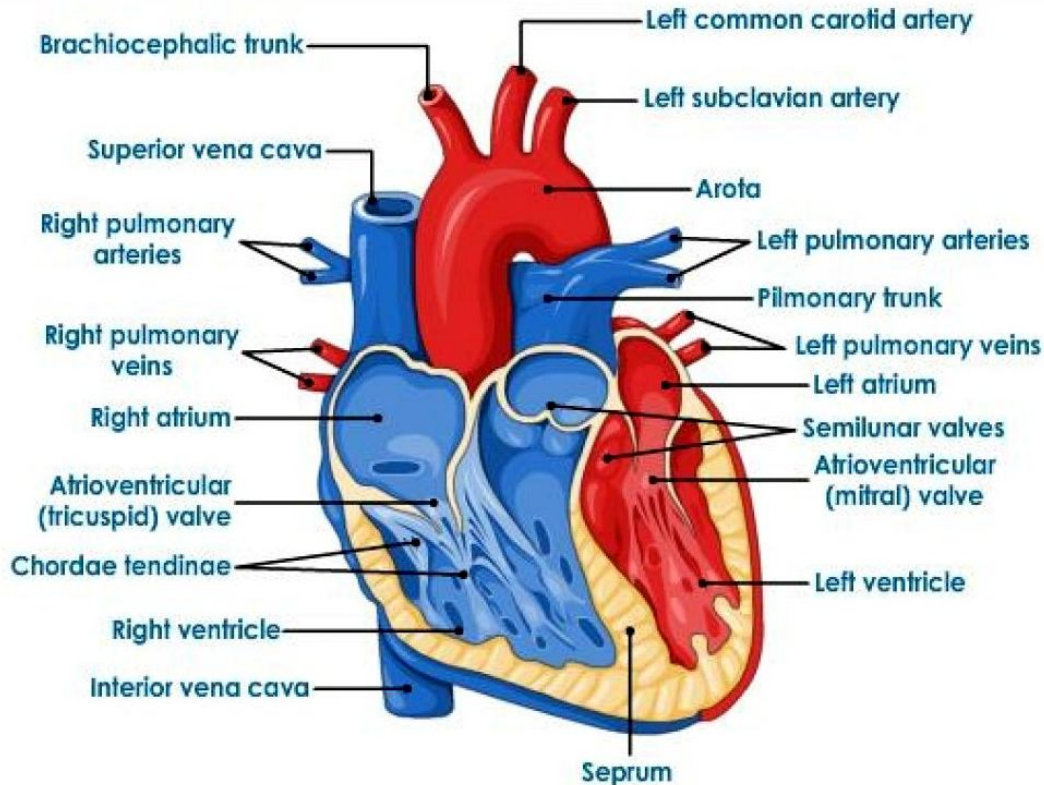

(b) The functions of blood and lymph are as follows:

(i) Blood

- Oxygen is transported by the blood to the tissues of the body for the breakdown of digested food.
- Carbon dioxide is transported to the lungs by the blood plasma.
- The digested and absorbed nutrients are transported by blood to the tissues. Nitrogenous wastes are transported to the kidneys.
- It regulates the body temperature and maintains the pH of the body tissues.
- It transports various hormones from one region to another and bring about the coordination.
- It maintains water balance to constant level.
- The lymphocytes produce antibodies against the invading antigens and protect from diseases.
- It helps in rapid healing of wounds by forming a clot at the site of injury.

(ii) Lymph

- It cleans the cellular environment.
- It returns proteins and tissue fluids to the blood (drainage)
- It provides a pathway for the absorption of fats and fat-soluble vitamins into the bloodstream.
- It defends the body against disease.

71. (a) Draw a labelled diagram of the respiratory system of human beings with diaphragm at the end of expiration.

(b) List four conditions required for efficient gas exchange in an organism.

Answer.(a)

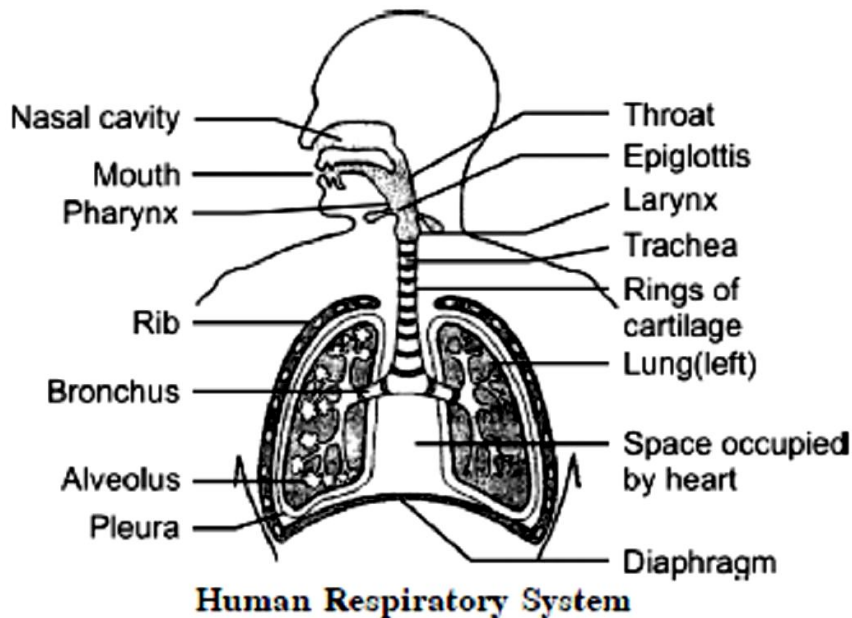

Human Respiratory System

- (b) (i) A large surface area over which exchange can take place.
- (ii) A concentration gradient without which nothing will diffuse.
- (iii) A thin surface across which gases diffuse.
- (iv) Warm conditions.

72. (a) Draw a diagram to show the nutrition in Amoeba and label the parts used for this purpose. Mention any other purpose served by this part other than nutrition.
 (b) Name the glands associated with digestion of starch in human digestive tract and mention their role.
 (c) How is required pH maintained in the stomach and small intestine?

Answer.(a)

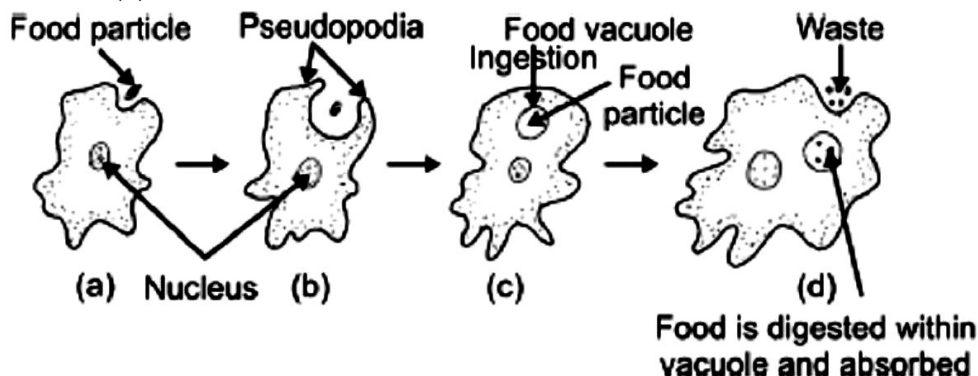

Nutrition in Amoeba

Pseudopodia serves the purpose of locomotion apart from nutrition.

(b) The salivary gland is associated with digestion of starch in human digestive tract. It secretes saliva which contains enzyme salivary amylase. This enzyme converts starch into maltose (sugar).

(c) Gastric glands present on the walls of the stomach release HCl. HCl creates an acidic medium, which facilitates the action of enzyme pepsin. Bile juice from liver makes the food alkaline in small intestine for the pancreatic enzymes to act.

73. (a) Leaves of a healthy potted plant were coated with vaseline to block the stomata. Will this plant remain healthy for long? State three reasons for your answer.

(b) State any two differences between autotrophic nutrition and heterotrophic nutrition.

Answer. (a) No, this plant will not remain healthy for long. The plant will begin to die because

- (i) Gaseous exchange will not take place.
- (ii) No absorption of CO₂, hence no photosynthesis.
- (iii) Transpiration will not occur; hence no transportation of water.

Autotrophic nutrition	Heterotrophic nutrition
(i) In this, the organisms make their food from carbon dioxide and water in the presence of sunlight and chlorophyll.	(i) In this, the organisms derive their food or nutrients from other living organisms.
(ii) All green plants are autotrophic and use light as a source of energy for synthesis.	(ii) The energy is derived from the intake and digestion of the organic substances.

74. (a) List the three events that occur during the process of photosynthesis.

Explain the role of stomata in this process.

(b) Describe an experiment to show that “sunlight is essential for photosynthesis.”

Answer.

(a) The three events that occur during the process of photosynthesis are:

(i) Absorption of light energy by the green pigment chlorophyll.

(ii) Conversion of light energy into chemical energy and the splitting of water molecule into hydrogen and oxygen.

(iii) Reduction of carbon dioxide into carbohydrate.

Role of Stomata

Stomata are tiny pores present on the surface of leaves. They are also present on the surface of young stems. Stomata are mainly engaged in the exchange of gases (entry of CO₂ and release of O₂) associated with photosynthesis. Plant closes the stomata when it does not need CO₂ for photosynthesis.

(b) Sunlight is essential for photosynthesis

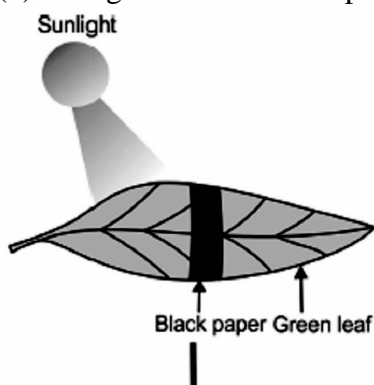

Procedure:

(i) Place a healthy green potted plant in a dark room for 1-2 days. This is done to ensure that the plant consumes all its reserve food and the leaves do not contain any starch.

(ii) Then, cover a portion of a leaf of this plant on both sides with two uniform pieces of black paper, fixed in position with two paper clips.

(iii) Now, expose this plant to bright light. After a few hours, remove the leaf and decolorize it with alcohol and test the presence of food (starch) with iodine solution.

Observation: It can be observed that the portion of the leaf covered with black paper does not (food),

Conclusion: This is because the food prepared by plants through the process of photosynthesis is stored as starch. Starch reacts with the iodine solution to give blue-black colour. Only those portions of the leaf that were exposed to sunlight could photosynthesise. Hence, gives blue- black colour when tested with iodine. The portion of the leaf covered with black paper did not receive sunlight. Hence, starch was not produced. Thus, it can be concluded that the sunlight is essential for photosynthesis.

75. (a) What is meant by breathing? What happens to the rate of breathing during vigorous exercise and why?

(b) Define translocation with respect to transport in plants. Why is it essential for plants?

Where in plants are the following synthesised?

(i) Sugar (iii) Hormone

Answer.(a) The process of taking in of oxygen from air in to the lungs and expulsion of carbon dioxide out of the lungs is called breathing. The rate of breathing during vigorous exercise increases by about 20 to 25 times per minute. It is because, during vigorous exercise the demand for oxygen increases. Breathing occurs involuntarily but its rate is controlled by the respiratory center of the brain.

(b) Translocation is the transport of food from the leaves to other parts of the plant and occurs in the part of the vascular tissue known as phloem.

It is essential for plants because every part of the plant needs food for obtaining energy for building its parts and maintaining its life.

(i) Sugar is synthesised in the leaves of the plant.

(ii) Hormones are synthesised at the tips of roots and stems of a plant.

76. (a) Explain how does the exchange of gases occur in plants across the surface of stems, roots and leaves.

(b) How are water and minerals transported in plants?

Answer. (a) In plants, there are tiny pores called stomata on leaves and lenticels in stem which facilitate the exchange of gases. CO₂ is taken in and O₂ given out (during photosynthesis) and vice-versa during respiration.

(b) Mechanism of Transport of Water and Minerals in a Plant

- The vessels and tracheids of roots, stems and leaves in xylem tissue are interconnected to form a continuous system of water-conducting channels reaching all parts of the plant.
- The cells of the roots in contact with the soil actively take up ions which creates a difference in the ion concentration between the root and the soil.
- Thus, there is steady movement of water into root xylem from the soil, creating a column of water that is pushed upwards.
- Plant uses another strategy to move water in the xylem upwards to the highest points of the plant body.
- The water which is lost through the stomata is replaced by water from the xylem vessels in the leaf.
- Evaporation of water molecules from the cells of a leaf creates a suction which pulls water from the xylem cells of roots.
- This loss of water is transpiration which helps in the absorption and upward movement of water and minerals dissolved in it from roots to the leaves.
- Transpiration becomes the major driving force in movement of water in the xylem during the day when the stomata are open.
- This mechanism is also known as cohesion of water theory or transpiration pull.

77. (a) Complete the glucose breakdown pathway in case of aerobic respiration by filling the blanks.

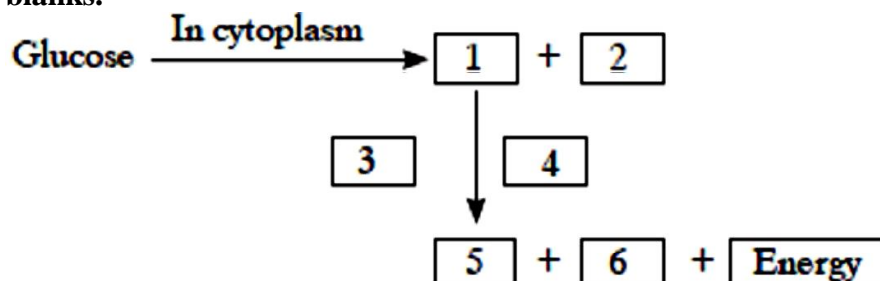

(b) Name the molecule in the cell which stores the energy produced at the end of the pathway.

(c) Why do we get cramps during vigorous muscular activity?

Answer. (a) (1) Pyruvate (3 carbon molecules) (2) Energy (3) Presence of oxygen (4) In Mitochondria (5) Carbon dioxide (6) Water

(b) ATP

(c) Lactic acid accumulation, in the absence of oxygen (anaerobic respiration) cause cramps.

78. (a) Draw the structure of a nephron and label the following on it:

Glomerulus, Bowman's capsule, Renal artery, Collecting duct.

(b) What happens to glucose that enters the nephron along with filtrate?

Answer.(a)

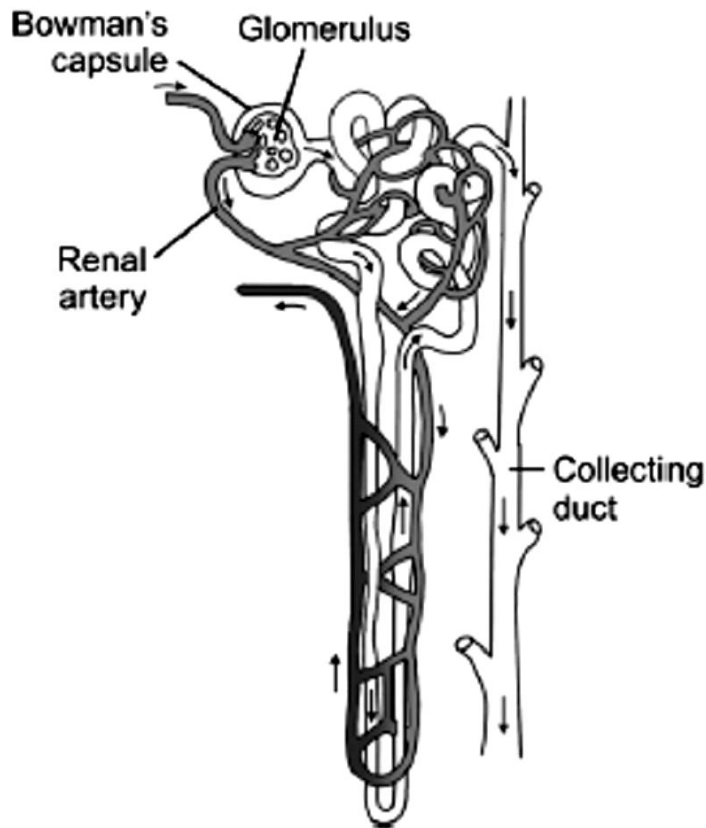

Structure of a Nephron

(b) During excretion in human beings, glucose which enters the nephron along with filtrate gets reabsorbed by blood capillaries surrounding the nephron.



CONTROL AND COORDINATION

VERY SHORT ANSWER TYPE QUESTION [1 MARK]

1. **How is the spinal cord protected in the human body?**

Answer. Spinal cord is enclosed in a bony cage called vertebral column.

2. **A potted plant is made to lie horizontally on the ground. Which part of the plant will show (i) positive geotropism?**

(ii) negative geotropism?

Answer.

(i) Root (ii) Shoot.

3. **Mention the function of the hind-brain in humans.**

Answer. Hind brain controls respiration, cardio-vascular reflexes and gastric secretions.

It also modulates the motor commands initiated by the cerebrum.

4. **Mention the function of adrenaline hormone.**

Answer. Adrenaline hormone is released into the blood from the adrenal gland during stimulation of the nervous system on seeing any adverse situation of fight or fright, it increases the blood pressure, it increases heart beat rate, it increases breathing rate and it diverts blood to essential organs including the heart, brain and skeletal muscles by dilating their blood vessels and constricting those of less essential organs, such as the skin and digestive system.

5. **A young green plant receives sunlight from one direction only. What will happen to its shoots ?**

Answer. Shoots will bend towards the light and roots away from the light.

6. **Name the plant hormones which help/promote (i) cell division (ii) growth of the stem and roots?**

Answer. The plant hormones which help or promote:

(i) Cell division — Cytokinins

(ii) Growth of the stem — Gibberellins

7. **What is the function of thyroxine hormone in our body ?**

Answer. Thyroxine hormone regulates the carbohydrate, protein and fat metabolism in the body so as to provide the best growth balance.

8. **Name two tissues that provide control and coordination in multicellular animals.**

Answer. The two tissues that provide control and coordination in multicellular animals are nervous and muscular tissues.

9. **Which one of the following actions on touch is an example of chemical control?**

(i) Movement on the touch-sensitive plant.

(ii) Movement in human leg.

Answer.

(i) Movement on the touch-sensitive plant.

10. **Name the part of the brain which controls posture and balance of the body.**

Answer. Cerebellum in hind-brain controls the posture and balance of the body.

11. **Mention the part of the body where gustatory and olfactory receptors are located.**

Answer. Gustatory receptors are located in Cerebrum of fore-brain. Olfactory receptors are located in Olfactory lobe of fore-brain.

12. **State the function of:**

(i) gustatory receptors, and

(ii) olfactory receptors.

Answer. (i) Gustatory receptors – these are sensitive to taste

(ii) Olfactory receptors – these are sensitive to smell.

13. **Why is it advised to use iodised salt in our diet ?**

Answer. Iodine stimulates the thyroid gland to produce thyroxin hormone. Deficiency of this hormone results in the enlargement of the thyroid gland. This can lead to goitre.

14. **State how concentration of auxin stimulates the cells to grow longer on the side of the shoot which is away from light ?**
Answer. When light falls on the side of the shoot auxin diffuses towards the shady side of the shoot. This concentration of the auxin stimulates the cell to grow longer on the side of the shoot which is away from light. Thus plant appears to bend towards light.
15. **Give an example of a plant hormone that promotes its growth. Where it is synthesized ?**
Answer. Plant hormone that promotes growth is auxin. It is synthesized at the tip of the plant stem.
16. **Name the two components of central nervous systems in humans.**
Answer. The two components of Central Nervous System in human are brain and spinal cord.
17. **What is the significance of reflex action?**
Answer. Reflex action enables the animal to respond quickly and relieves the brain from excess work.
18. **Give one example of chemotropism.**
Answer. The growth of pollen tube towards a chemical produced by ovule during fertilisation of flower is an example of chemotropism.
19. **Where are Nissl's granules found and what is their nature?**
Answer. Nissl's granules are found in cyton and dendrites. These are formed of ribonucleic acid (RNA).
20. **Name the fluid that is found between the meninges.**
Answer. Cerebrospinal fluid.

SHORT ANSWER TYPE QUESTION [I] [2 MARKS]

21. **What is synapse ? In a neuron cell how is an electrical impulse created and what is the role of synapse in this context ?**
Answer. A synapse is the gap between the two neurons. Here the axon terminal of one neuron is in close proximity to the dendrite of the second neuron. When a nerve impulse reaches the knob like nerve ending of an axon, a tiny amount of a chemical substance is released in the synapse. This chemical substance is called as the neurotransmitter. At synapse the electrical signals converted into chemicals, that can easily cross over the gap and pass on to the next neurons where it again converted into electrical signals.
22. **Name, the two main organs of our central nervous system. Which one of them plays a major role in sending command to muscles to act without involving thinking process? Name the phenomenon involved.**
Answer. The two main organs of CNS are brain and spinal cord. Spinal cord plays a major role in sending command to muscles to act without involving thinking process. This phenomenon is called reflex action.
23. **Name the hormone secreted by human testes. State its functions.**
Answer. Testes secrete male sex hormone called testosterone. The function of testosterone is to regulate male accessory sex organs and secondary sexual characters like moustache, beard and voice.
24. **Name and explain the function of the hormone secreted by the pituitary gland in humans.**
Answer. Hormones secreted by pituitary gland alongwith their functions are:
 - **Growth hormone:** It regulates growth and development of bones and muscles.
 - **Trophic hormone:** It regulates secretion of hormones from other endocrine glands.
 - **Prolactin hormone:** It regulates the function of mammary glands in females.
 - **Vasopressin hormone:** It regulates water and electrolyte balance in the body,
 - **Oxytocin hormone :** It regulates ejection of milk during lactation.
25. **What are 'nastic' and 'curvature' movements? Give one example of each.**
Answer. Nastic movements: These are non-directional movements which are neither towards nor away from the stimulus. Example: Drooping of leaves.

Curvature movements: In such movements plant organs move towards or away from the stimulus.
Example: Bending of shoot towards a source of light.

26. **Write the name and functions of any two parts of the human hind-brain.**

Answer. Any two parts of human hind-brain with their functions are as follows:

(i) Cerebellum, which controls the coordination of body movement and posture. (ii) Medulla oblongata, which regulates the centre of swallowing, coughing, sneezing and vomiting.

27. **What are plant hormones? Write two important functions of auxin.**

Answer. Plant hormones can be defined as a chemical substance which is produced naturally in plants and are capable of translocation and regulating one or more physiological processes when present in low concentration. .

Two important functions of auxin are that it promotes cell elongation, root formation, cell division, etc.

28. **Which organ secretes a hormone when blood sugar rises in our body? Name the hormone and name one enzyme released by this organ.**

Answer. Pancreas secretes a hormone when blood sugar rises in our body. Insulin is the hormone released by this organ and the name of the enzyme is pancreatic juice.

29. (a) **Which plant hormone is present in greater concentration in the areas of rapid cell division?**

(b) **Give one example of a plant growth promoter and a plant growth inhibitor.**

Answer.

(a) Cytokinin is present in greater concentration in the areas of rapid cell division.

(b) An example of a plant growth promoter is gibberellins and example of a plant growth inhibitor is abscisic acid.

30. (i) **Name the hormones that are released in human males and females when they reach puberty.**

(ii) **Name a gland associated with brain. Which problem is caused due to the deficiency of the hormone released by this gland ?**

Answer.

(i) Testes in males produces hormone testosterone.

Ovaries in females produces hormone oestrogen.

(ii) Pituitary gland present in the brain is responsible for body growth, development of bones and muscles (if excess-gigantism) (if less-dwarfism).

31. **Distinguish between spinal nerve and cranial nerve.**

Answer.

Spinal nerve	Cranial nerve
(i) They arise from spinal cord.	(i) They arise from brain.
(ii) There are 31 pairs of spinal nerves.	(ii) There are 12 pairs of cranial nerves.

32. **How does control and coordination take place in plants ?**

Answer. In plants, control and coordination is brought about by means of chemical substances called phytohormones. In addition, environmental factors like water, temperature and light, controls growth and development.

33. **Write the difference between cerebellum and cerebrum.**

Answer.

Cerebrum	Cerebellum
(i) It is the largest highly developed and prominent part of the brain.	(i) It is the second largest part of the brain and lies at the posterior part of the brain.
(ii) It is the controlling centre for senses. It is responsible for memory, intelligence, hearing, etc.	(ii) It controls the skeletal, muscle activities and maintains the equilibrium of the body.

34. Distinguish between sympathetic and parasympathetic nervous system.

Answer.

Sympathetic Nervous System	Parasympathetic Nervous System
(i) It consists of double chain of ganglia situated on either side of spinal cord.	(i) Ganglia of this system are also paired but are situated nearer to visceral organs.
(ii) Nerve fibres connect these ganglia with the CNS and visceral organs.	(ii) Its original place is in the brain and the posterior parts of the spinal cord.
(iii) It prepares the body for an abnormal situation.	(iii) It prepares the body for normal functioning after abnormal situation.

35. Distinguish between cerebrum and spinal cord.

Answer.

Cerebrum	Spinal cord
(i) It contains cell bodies of neurons outside and axons of the neurons inside.	(i) It contains axons outside and cell bodies inside.
(ii) It is the region for memory, speech, reasoning, etc.	(ii) It controls the reflex actions.

SHORT ANSWER TYPE QUESTIONS[II] [3 MARKS]

36. Smita's father has been advised by a doctor to reduce his sugar intake.

Name the disease he is suffering from and name the hormone whose deficiency is? ,

Identify the gland that secretes it and mention the function of this hormone.

Explain how the time and amount of secretion of this hormone is regulated in human system.

Answer.

He is suffering from diabetes. Deficiency of insulin causes diabetes.

Pancreas secretes insulin. Insulin helps in regulating blood sugar.

When the sugar level in blood increases, it is detected by the a-cells of the pancreas which responds by producing more insulin. As the blood sugar level falls, insulin secretion is reduced.

37. State the functions of plant hormones. Name four different types of plant hormones.

Answer. Plant hormones help to coordinate growth, development and responses in environment.

Four different types of plant hormones are – Auxins, Gibberellins, Cytokinins, Ethylene and Abscisic acid.

- Auxins control the tropic (growth related) movements of the plants in response to light, gravity, touch etc by increasing the size of cells. Under the influence of auxins, the plant stem bends towards unidirectional light where as the roots bend away from it.
- Gibberellins stimulate stem elongation and leaf expansion. Its application causes stem elongation in small plants such as cabbage. Spraying gibberellins on sugarcane plant increases the stem size and hence the yield.
- Cytokinins are produced in regions of the plant body where rapid cell division occur, such as root tips, developing shoot buds, young fruits and seeds. Cytokinins promote growth by stimulating cell division. They also help in production of new leaves and chloroplasts in leaves.
- Ethylene causes ripening of the fruits.
- Abscisic acid inhibits (i.e., slows down) the growth in different parts of the plant body. It also inhibits germination of seeds. It increases the tolerance of plant to different kinds of stresses such as temperature changes. So, it is also called the stress hormone in plants. It also causes the drying and falling of older leaves, flowers and fruits.

38. (a) How is brain protected from injury and shock?
 (b) Name two main parts of hind brain and state the functions of each.

Answer.

(a) Brain is covered by a three layered membrane called meninges. In between the layers of meninges and brain, cavity fluid named Cerebro Spinal Fluid (CSF) is filled. The hard skull covers the meninges. Thus Meninges, CSF and Skull protects our brain for a certain extent.

(b) Two main parts of hind-brain are — Medulla and Cerebellum. Their functions are:

Medulla : Involuntary actions such as blood pressure, salivation and vomiting.

Cerebellum : It is responsible for precision of voluntary actions and maintaining the posture and balance of the body.

39. (a) Draw the structure of neuron and label cell body and axon.
 (b) Name the part of neuron:
 (i) where information is acquired
 (ii) through which information travels as an electrical impulse.

Answer. (a) A nerve cell (Neuron)

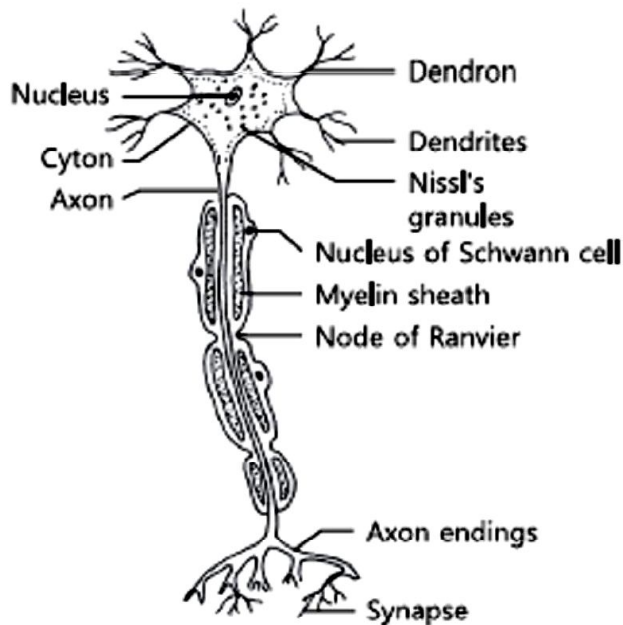

A nerve cell (Neuron)

(b) (i) Dendrite (ii) Axon

40. Draw neat diagram of human brain and label on it the following parts :
 (i) Midbrain (ii) Pituitary gland

Answer.

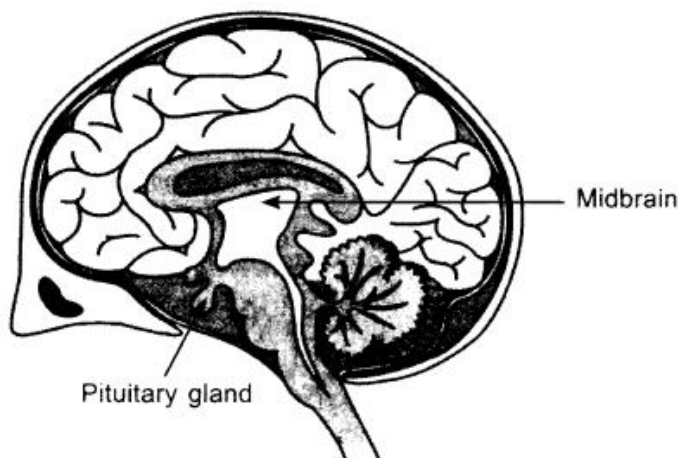

Human brain

41. What is synapse? In a neuron cell how is an electrical impulse created and what is the role of synapse in this context?

Answer. Synapse is the junction between two adjacent neuron or nerve cells, i.e. between axon ending of one and the dendrite of the next. Transmission of Nerve Impulse. The information acquired at the end of the dendritic tip of a neuron sets off a chemical reaction which creates an electrical impulse. This impulse travels from the dendrite to the cyton along the axon to its end. At the end of the axon, the electrical impulse sets off the release of some chemicals, which cross the synapse and start a similar electrical impulse in a dendrite of the next neuron. In this way nerve impulses travel in the body. Synapse helps in transmitting impulses from one neuron to another.

42. **Write one example each of the following tropic movements :**

- (i) **Positive phototropism** (ii) **Negative phototropism**
 (iii) **Positive geotropism** (iv) **Negative geotropism**
 (v) **Hydrotropism** (vi) **Chemotropism**

Answer.

- (i) Positive phototropism: shoots growing towards light.
 (ii) Negative phototropism: roots growing away from light towards ground.
 (iii) Positive geotropism: growth of roots towards earth due to the pull of the earth.
 (iv) Negative geotropism: shoots growing away from the earth.
 (v) Hydrotropism: roots growing towards the source of water.
 (vi) Chemotropism: growth of pollen tubes towards the ovules.

43. (a) **Explain any three directional movements in plants.**

(b) **How brain and spinal cord are protected in human ?**

(c) **Name the master gland present in the brain.**

Answer.

(a) Stimuli is responsible for the movement of the plant parts towards or away from it. This movement is called as Tropic Movement.

Phototropism: movement of plant towards or away from the light. **Geotropism:** movement of plant parts towards the earth or away from it. **Hydrotropism:** movement of plant parts towards or away from any source of water.

(b) Both the brain and the spinal cord are protected by bone: the brain by the bones of the skull and the spinal cord is protected by a set of ring-shaped bones called vertebrae. They are both cushioned by layers of membranes called meninges as well as a special fluid called cerebrospinal fluid. This fluid helps to protect the nerve tissue to keep it healthy, and remove waste products.

(c) Pituitary gland present in the brain is known as the master gland.

44. **List in tabular form three differences between nervous system and Endocrine system.**

Answer.

Nervous System	Endocrine System
(i) Formed of a collection of neuron cells.	(i) Formed of a set of glands.
(ii) Electrochemical pulses are the mean of signal transmission.	(ii) Chemicals called hormones are the means of signal transmission.
(iii) Signal transmission is fast, but the functions are not prolonged.	(iii) Signal transmission is slow, but the functions are long lasting.
(iv) The cells are interconnected and the whole system is continuous.	(iv) The organs of the whole system are not physically connected yet those are discrete.
(v) Use the neurons to transmit the signal.	(v) Use the circulatory system to transmit the signal.

45. (a) **Explain how auxins help in bending of plant stem towards light.**

(b) **State the objective of the experiment for which experimental set-up is shown in the given diagram.**

Answer.

(a) In plant shoots, the role of auxin is to cause a positive phototropism, i.e. to grow the plant

towards the light. When light is incident on a plant from one direction, it causes the auxins to redistribute towards the shaded side of the plant. One function of auxin is to cause cell elongation. The redistribution causes the cells on the shaded side to elongate more than those on the side with the light shining on them. This causes the shoot to bend towards the light.

(b) The objective of the experiment is to show phototropic movement of plant.

46. **What causes a tendril to encircle or coil around the object in contact with it is? Explain the process involved.**

Answer. When a tendril comes in contact with any support, the part of the tendril in contact with the object does not grow as rapidly as the part away of the tendril away from the object. This cause the tendril to circle around the object and thus, cling to it.

47. **Name any three endocrine glands in human body and briefly write the function of each of them.**

Answer. Three endocrine glands with their function in human body are as follows:

- **Thyroid gland :** It secretes a hormone called thyroxine which regulates the metabolism of carbohydrates, fats and proteins in the body and so provide the best balance for nutrients and mental ability.
- **Adernal gland :** It secretes two hormones—adrenalin and corticoid hormones regulate blood pressure, heartbeat, breathing rate and carbohydrate metabolism.
- **Pancreas:** It secretes two hormones—insulin and glucagon. Insulin hormone lowers the blood glucose level. Glucagon hormone increases the blood glucose level.

48. **Which part of the brain controls involuntary actions? Write the function of any two regions of it. Answer.** Hind-brain controls the involuntary actions. Cerebellum controls the coordination of body movement and posture. Medulla oblongata regulates center for swallowing, coughing, sneezing and vomiting.

49. **What is chemotropism? Give one example. Name any two plant hormones and mention their functions.**

Answer. Chemotropism is the movement of a part of the plant in response to a chemical stimulus. It can be positive chemotropism or negative chemotropism. Example: The growth of pollen tube towards a chemical which is produced by an ovule during the process of fertilisation in a flower.

Two plant hormones with their functions are as follows:

Auxins promote cell elongation, root formation, cell division, respiration and other physiological processes like protein synthesis, etc.

Gibberellins stimulate stem elongation, seed germination and flowering.

50. **State the functions of any three of the structural and functional unit of nervous system.**

Answer. The structural and functional unit of nervous system, i.e. neuron with their functions are as

- **Cell body:** Stimulus received from dendrite is changed into impulse in the cyton.
- **Dendrites:** They receive sensation or stimulus, which may be physical or chemical.
- **Axon:** It conducts impulse away from the cell body.

51. **Define ‘hormones’. Name the hormone secreted by thyroid. Write its function. Why is the use of iodised salt advised to us?**

Answer. Hormones are the chemical substances which coordinate and control the activities of living organisms and also their growth. The hormone secreted by thyroid is thyroxine. Its function is to regulate the metabolism of carbohydrates, fats and proteins in the body so as to provide the best balance for growth. The use of iodised salt is advised to us because iodine is necessary for the thyroid gland to produce thyroxine hormone. Thyroxine regulates carbohydrate, protein and fat metabolism which is required for growth. Deficiency of iodine in the body causes disorder like swollen neck and disease called goitre.

52. **What is ‘hydrotropism’? Describe an experiment to demonstrate ‘hydrotropism’.**

Answer. ‘Hydrotropism’ is the directional growth of a plant part in response to water. For example, roots show hydrotropism as they grow towards water in the soil and are positively hydrotropic.

An experiment to demonstrate hydrotropism is as follows:

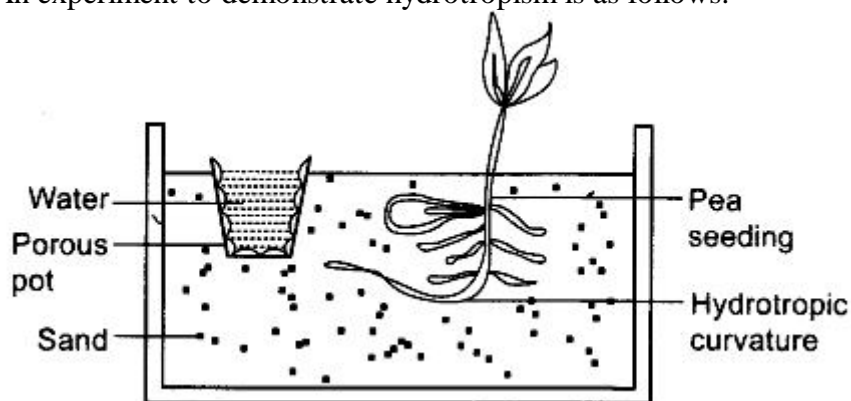

- A porous pot filled with water is taken and inserted in a tub filled with dry sand.
- A freshly germinated pea seedling is sowed in the sand.
- As water is not available in sand, the root growing will bend towards the porous pot filled with water.
- A hydrotropic curvature of the root is observed as it grows towards water.
- This bending of root shows the movement in response towards water.

53. **What are 'hormones'? State one function of each of the following hormones:**

(i) **Thyroxine** (ii) **Insulin**

Answer. Hormones are the chemical substances which coordinate and control the activities of living organisms and also their growth. The term hormone was introduced by Bayliss and Starling.

(i) **Function of Thyroxine:** This hormone regulates the metabolism of carbohydrates and fats.

(ii) **Function of insulin:** This hormone helps in regulating sugar level in the blood.

54. **What is the function of receptors in our body? Think of situation where receptors do not work properly. What problems are likely to arise?**

Answer. Receptors are present in our all parts of the body for example in skin, eye, nose tongue etc. They detect the signals and then send them to brain in the form of electrical signals. If these receptors are damaged then it they will not detect the input which leads to the harm for our body in dangerous situation.

55. **What is a reflex action? Describe the steps involved in a reflex action.**

Answer.

Reflex action: It is defined as an unconscious, automatic and involuntary response of effectors, i.e. muscles and glands, to a stimulus, which is monitored through the spinal cord.

Mechanism of reflex action : It involves the following steps:

- Receptor organ like skin perceives the stimulus and activates a sensory nerve impulse.
- Sensory organ carries message in the form of sensory impulse to the spinal cord.
- The spinal cord acts as modulator : The neurons of spinal cord transmit the sensory nerve impulse to motor neuron.
- Motor never conducts these impulses to the effectors like leg muscles which responds by pulling back the organ away from the harmful stimulus.

56. **List the components of reflex arc in correct sequence. State in brief the role of brain in reflex action.**

Answer. The reflex arc pathway is shown in the flow chart as follows:

The Reflex arc does not involve brain. It minimises the overloading of brain.

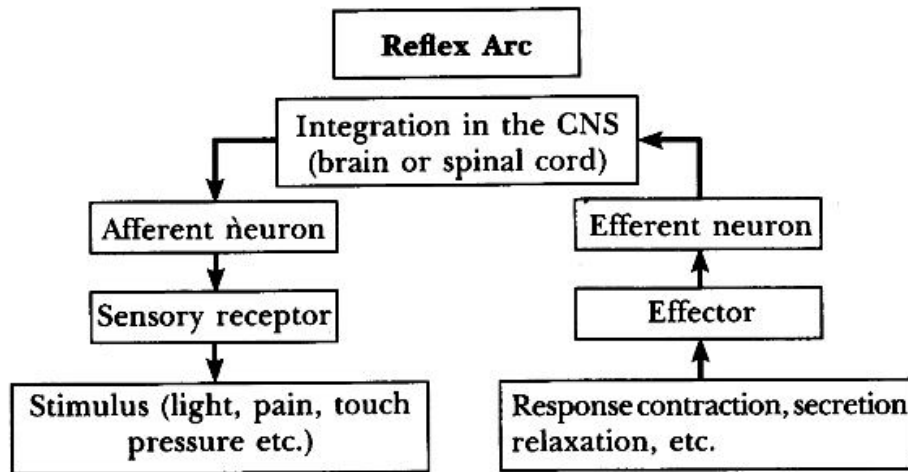

57. (a) Name the two main constituents of the Central Nervous System in human beings.
 (b) What is the need for a system of control and coordination in human beings?

Answer.(a) The two main constituents of the Central Nervous System in human beings are the brain and the spinal cord.

(b) A living being does not live in isolation. It has to constantly interact with its external environment and has to respond properly for its survival. For example; when a hungry lion spots a deer, the lion has to quickly make a move so that it can have its food. On the other hand, the deer needs to quickly make a move to run for its life. The responses which a living being makes in relation to external stimuli are controlled and coordinated by a system; especially in complex animals. So, control and coordination is essential in maintaining a state of stability and a steady state between the internal conditions of an organism and the external environment.

58. Mr. Bora has a habit to iron his shirt every morning before going to office. One morning he forgot to keep the hot iron in proper place and left for office. His two years old daughter touched the iron and her hand got burnt. Mrs. Bora immediately put the hand of her daughter under a running tap as a first aid.

- (a) What value was shown by Mrs. Bora?
 (b) How do we react when we touch a hot object?
 (c) What other materials commonly cause burn injury?

Answer. (a) Mrs. Bora showed the value of adequate knowledge on a subject and capability to use it when required.

(b) We immediately remove the hand from the hot object due to reflex action.

(c) Hot running water, hot tea/coffee/milk/water, hot cooking ware, hot food items and hot electrical appliances are other common materials which commonly cause burn injury.

59. A young boy met an accident while riding a bike. Petrolling police found the boy and brought him to a hospital for treatment. After the accident, the boy lost his memory completely. Left side of his body also suffered from paralysis.

- (a) What values were shown by police persons?
 (b) Which injured body part can cause paralysis?
 (c) What precaution should one take while riding a two-wheeler?

Answer. (a) The values showed by the police persons were truthful to duty and humanity.

(b) Injury to brain or spinal cord can cause paralysis.

(c) Riders must wear helmets while riding a two-wheeler. One must drive in a controlled speed to avoid accident.

LONG ANSWER TYPE QUESTIONS [5 MARKS]

60. (a) Name the hormone which is released into the blood when its sugar level rises. Explain the need of Chemical communication in multicellular organisms the organ which produces this hormone and its effect on blood sugar level. Also mention the digestive enzymes secreted by this organ with one function of each.

(b) Explain the need of Chemical communication in multicellular organisms.

Answer.

(a) Glucose is needed by cells for respiration. It is important that the concentration of glucose in the blood is maintained at a constant level. Insulin is a hormone produced by the α -cells that regulates glucose levels in the blood.

In order for multicellular organisms to function properly, their cells must communicate. For instance, your muscles must contract when your brain sends a message to contract.

Pancreas produces insulin and β -cells which increase glucose in blood. It also – produces digestive enzyme (pancreatic amylase).

(b) Cell-to-cell signaling is a critical component of coordinating cellular activities. Through this communication, messages are carried from signaling cells to receiving cells, also known as target cells. This signaling occurs with proteins and other types of signaling molecules. Other things which happens in our body due to cell communication are – growth and development, cellular reproduction, tissue repair, sensing pain, etc.

61. What is meant by reflex-action ? With the help of a labelled diagram trace the sequence of events which occur when we touch a hot object.

Answer. Stimulus: In the example above, the stimulus is the contact with the hot pot. This contact causes a nerve impulse that will travel to the spinal cord via the sensory neurons.

Sensory neurons: These neurons carry the nerve impulse to the spinal cord. Similar to the interneuron and motor neuron, sensory neurons receive incoming impulses at the dendrites. The impulses move away from the cell body along the axon to the synaptic terminal where the impulse is sent to the next interneuron with the help of a neurotransmitter (acetylcholine).

Interneurons: The interneuron is also known as relay neuron. These neurons are fully contained in the central nervous system. The interneuron serves as the connection between the sensory neurons and the motor neurons. Synapse: The synapse is a tiny space between two neurons. When an impulse gets to the end of one neuron and has to be sent down to the next neuron, the synapse acts as a bridge. The signal arrives at the end of one neuron (close to the synapse) as an electrical signal, crosses the synapse as a chemical signal (with the help of a neurotransmitter known as acetylcholine released by the synaptic vesicles at the synaptic terminal) and continues as an electrical signal in the next neuron.

Motor neurons: These neurons send nerve impulses away from the central nervous system to effector organs or muscle fiber in our example above. This causes the muscle fiber to contract, resulting in you snatching your hand away from the hot pot.

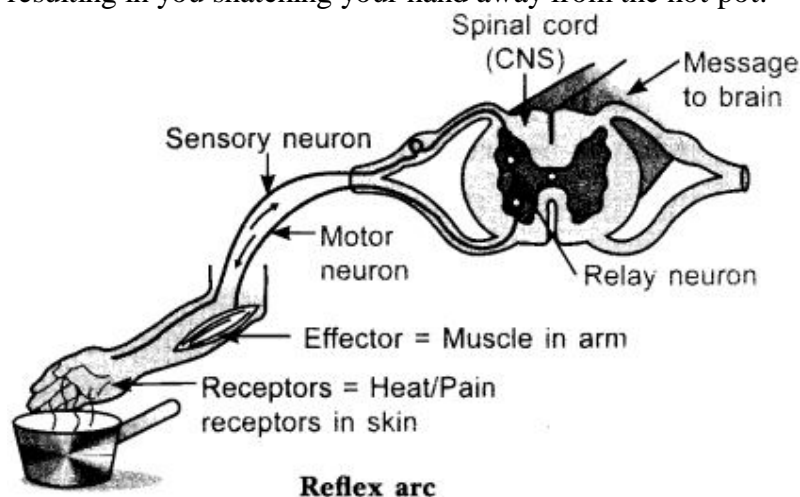

Response: To respond to the stimulus of the reflex arc, the muscle needs to contract to pull the hand quickly away from the hot pot. For this to happen, the impulse travels to the synaptic terminal of the motor neuron. Synaptic vesicles at the synaptic terminal will then release acetylcholine which will cross the synapse and bind to the receptors on the muscle fibers to trigger the muscle contraction known as the 'response'.

62. **State the structural and the functional unit of the nervous system. Draw its neat labelled diagram and write two functions.**

Answer. The structural and functional unit of the nervous system is the neuron.

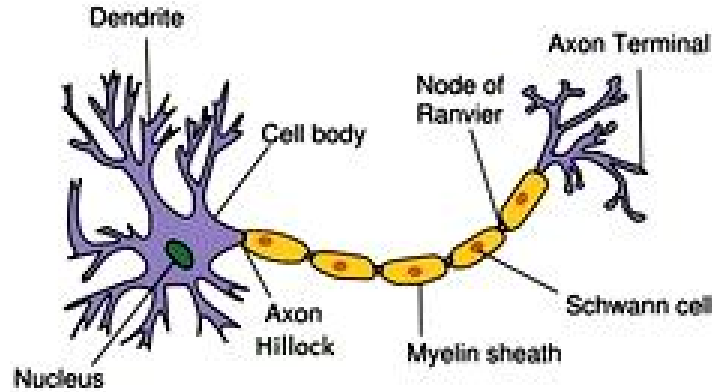

The functions of the neuron are:

(a) Passing of information takes place-

(i) By electric impulse (inside the neuron) and

(ii) In the form of chemicals (At synapse)

(b) Reflex action- spontaneous, involuntary and automatic response to a stimulus to protect us from harmful situations. For example, on touching a hot object unknowingly we instantly withdraw our hand.

63. **What is a reflex arc? Draw a neat labelled diagram of the components in a reflex arc. Why do impulses flow only in one direction in a reflex arc?**

Answer. Reflex arc is the pathway taken by the nerve impulses and responses in a reflex action, i.e. from the receptor organs like skin to the spinal cord and from the spinal cord to the effector organs like muscles.

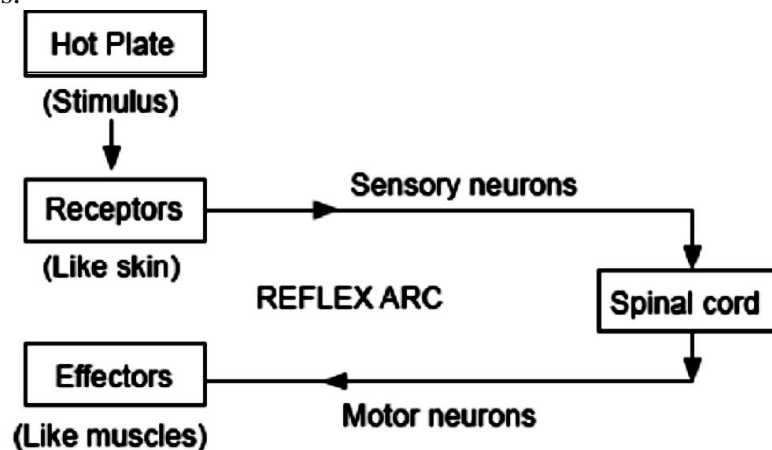

Impulses flow only in one direction in a reflex arc, because each synapse in the reflex arc allows impulses to cross it in a single direction.

64. **Suggest six reflex actions of the body. Explain how the reflex arc is the same in all of them.**

Answer. Six reflex actions of the body are:

(i) When we see a speeding car moving towards us, we move aside.

(ii) We withdraw our hands on being pricked by a pin.

(iii) We withdraw our hands on touching very hot substance.

(iv) We close our eyes on seeing direct sun or extremely bright source of light.

(v) We close our eyes on hearing a loud noise.

(vi) We shiver on feeling cold.

Reflex arc in all the above cases is same because in all the cases, the stimulus is received by sense organs. Then this information is carried to spinal cord through sensory nerves. Thus, information from spinal cord is sent to the effectors such as muscles via motor neurons.

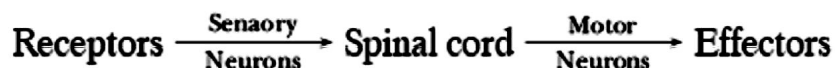

65. (a)

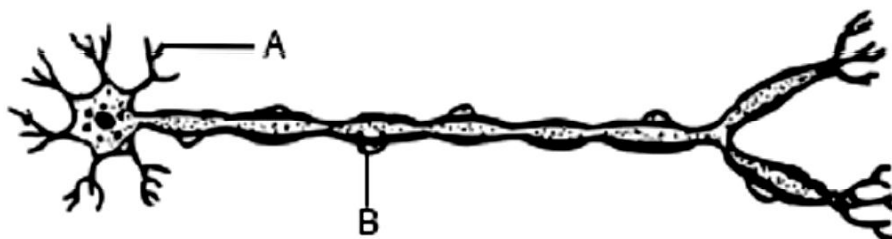

(i) Name the parts labelled A and B in the neuron drawn above.

(ii) Which part acquires the information in the neuron?

(iii) Through which part does the information travel?

(iv) In what form does this information travel?

(v) Where is the impulse converted into a chemical signal for onward transmission?

(b) Name the hormone secreted by thyroid. What is its function? Why is the use of iodised salt advisable.

Answer. (a) (i) A – Dendrite, B – Axon

(ii) The information in the neuron is acquired at the end of the dendrite tip.

(iii) The information travels from the dendrite to the cell body and then along the axon to its end.

(iv) The information travels in the form of an impulse.

(v) The impulse is converted into a chemical signal at the end of the axon.

(b) Thyroxine hormone is secreted by thyroid.

Function of Thyroxine hormone :

It regulates carbohydrate, protein and fat metabolism in the body so as to provide the best balance for growth. The use of iodised salt is advisable because iodine is essential for the synthesis of thyroxin. In case of iodine deficiency in our diet, there is a possibility one can suffer from goitre, which is a disease of swollen neck.

OUR ENVIRONMENT

VERY SHORT ANSWER TYPE QUESTIONS [1 Mark]

1. **What will happen if we kill all the organisms in one trophic level?**

Answer. If we kill all the organisms in one trophic level, the following effects will take place:

- The population of organisms in previous trophic level will increase.
- The organisms in next trophic level will not be able to get the food, so they will migrate to some other ecosystem or die.
- It will cause an ecological imbalance in the food chain.

2. **Why did United Nations act to control the production of chlorofluorocarbons (CFCs) used in refrigerators?**

Answer. CFCs deplete the ozone layer around the earth, hence their production is controlled by United Nations.

3. **Which compounds are responsible for the depletion of ozone layer?**

Answer. The compounds responsible for the depletion of ozone layer are chlorofluorocarbons (CFCs).

4. **Define 'trophic level'.**

Answer. Trophic level is the position that an organism occupies in a food chain, where transfer of food or energy takes place.

5. **What are the various steps in a food chain called?**

Answer. The various steps in a food chain are called trophic levels.

6. **What is the important function of presence of ozone in earth's atmosphere?**

Answer. The important function of presence of ozone in earth's atmosphere is that it shields the surface of the earth from ultraviolet (UV) radiations of the sun.

7. **Give an example to illustrate that indiscriminate use of pesticides may result-in the degradation of the environment.**

Answer. The pesticides used in crop field are washed down into the water bodies. From water bodies, these are absorbed by aquatic plants and animals of a food chain and thereby degrades the environment.

8. **Why is it necessary to conserve our environment?**

Answer. It is necessary to conserve our environment to prevent depletion of natural resources and environmental damage, thereby sustaining life.

9. **What is meant by a biodegradable waste?**

Answer. Biodegradable wastes are those substances which are broken down into simpler, harmless substances in nature in due course of time by the biological processes such as action of micro organisms like certain bacteria.

Examples: Urine and faecal matter, sewage, agricultural residue, paper, wood, cloth and cattle dung.

10. **What is the role of decomposers in the ecosystem?**

Answer. Role of decomposers in the environment:

- They return the nutrients to the nutrient pool.
- They help in completing the different bio-geochemical cycles, thus they maintain the balance in the ecosystem.

11. **What step is being taken to limit the damage to the ozone layer?**

Answer.

Judicious use of aerosol spray propellants such as fluorocarbon and chlorofluorocarbons which cause depletion or hole in ozone layer.

Control over large scale nuclear explosions and limited use of supersonic planes.

12. **Why are some substances non- biodegradable?**

Answer. Some substances are non-biodegradable because they cannot be broken down into simpler harmless substances in nature.

13. **Which class of chemicals is linked to the decrease in the amount of ozone in the upper atmosphere of the earth?**

Answer. The chemical compound Chlorofluorocarbon is responsible for decrease of ozone in the upper atmosphere of the earth.

14. **Name two decomposers operating in our ecosystem.**

Answer. Bacteria and fungi.

15. **Select two non-biodegradable substances from the following waste generated in a kitchen: spoiled food, paper bags, milk bags, vegetable peels, tin cans, used tea leaves.**

Answer. Milk bags and tin cans.

16. **What happens when higher energy ultraviolet radiations act on the oxygen at the higher level of the atmosphere?**

Answer. When high energy ultraviolet radiations act on oxygen, ozone is produced:

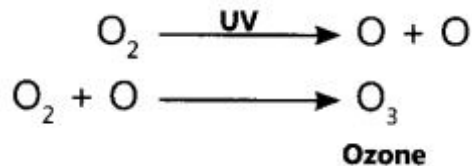

17. **In a food chain, 10,000 joules of energy is available to the producer. How much energy will be available to the secondary consumer to transfer it to the tertiary consumer?**

Answer. 10 J will be available to the secondary consumer to transfer to the tertiary consumer.

18. **Write the name and formula of a molecule made up of three atoms of oxygen.**

Answer. Ozone and its chemical formula is O₃.

19. **List two man-made ecosystems.**

Answer. Garden and Pond are man-made ecosystems.

20. **Consider the following food chain which occurs in a forest: Grass -> Deer -> Lion**

If 10000 J of solar energy is available to the grass, how much energy would be available to the deer to transfer it to the lion?

Answer. 10 J energy would be available to deer to transfer to lion.

21. **Which of the following belong to the first trophic level of a food chain? Grass, Grasshopper, Plants, Rat, Tiger**

Answer. Grass and plants belong to the 1st trophic level of a food chain.

22. **Name the phenomenon in which non-biodegradable chemicals get accumulated progressively at each trophic level of a food chain.**

Answer. Biological magnification.

23. **How is the increase in demand for energy affecting our environment adversely?**

Answer. The increase in demand for energy affects our environment adversely. Due to this increase, pollutants like CO, CO₂, SO₂, etc., are released in to the atmosphere which leads to greenhouse effect.

24. **Why is ozone layer getting depleted at the higher levels of the atmosphere?**

Answer. Ozone layer is getting depleted at the higher levels of the atmosphere due to effect of chlorofluorocarbons (CFC_s) which are used as refrigerants and in fire extinguishers.

25. **Name any two abiotic components of an environment.**

Answer. Two abiotic components of an environment are temperature and rainfall.

26. **What are the two main components of our environment?**

Answer. The two main components of our environment are the biotic or living components and abiotic or non-living components.

27. **Why are green plants called 'producers'?**

Answer. Green plants are called 'producers' because they can produce food by photosynthesis in the presence of sunlight.

28. **Which disease is caused in human beings due to depletion of ozone layer in the atmosphere?**

Answer. Skin cancer is caused in human beings due to the depletion of ozone layer in the atmosphere.

29. Why should biodegradable and non-biodegradable wastes be discarded in two separate dustbins?

Answer. Biodegradable materials are broken down by microorganisms in nature into simple harmless substances. Non-biodegradable materials need a different treatment like heat and temperature and hence these should be discarded in separate bins.

30. List two natural ecosystems.

Answer. Two natural ecosystems are forest and river.

31. List two biotic components of a biosphere.

Answer. Two biotic components of a biosphere are plants and animals.

32. What will be the amount of energy available to the organism of the 2nd trophic level of a food chain, if the energy available at the first trophic level is 10,000 joules?

Answer. 100 Joules of energy will be available to the organism of the 2nd trophic level.

33. The following organisms form a food chain. Which of these will have the highest concentration of non-biodegradable chemicals? Name the phenomenon associated with it. Insects, Hawk, Grass, Snake, Frog.

Answer. Hawk will have highest concentration of non-biodegradable chemicals. The phenomenon is called biomagnification.

34. List two criteria of measuring the biodiversity of an area.

Answer. One measure of the biodiversity of an area is the number of species found there. Secondly, the range of different life forms is also important.

35. The first trophic level in a food chain is always a green plant. Why?

Answer. Only green plants can make their own food from sunlight. Green plants therefore, always occupy the 1st trophic level in a food chain.

SHORT ANSWER TYPE QUESTIONS [I] [2 Marks]

36. How is ozone formed in the upper atmosphere? Why is the damage of ozone layer a cause of concern to us? State a cause of this damage.

Answer. Ozone is formed in upper atmosphere by the reaction of ultraviolet (UV) radiations on oxygen (O_2) molecule.

The damage to ozone layer is a cause of concern to us as due to its damage, more ultraviolet rays reach the earth's surface causing various health hazards.

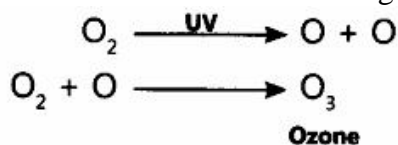

A cause of this damage is the presence of large amount of chlorofluorocarbons in the atmosphere.

37. State two problems caused by the non- biodegradable waste that we generate in our daily life.

Answer. Two problems caused by non-biodegradable waste that we generate in our daily life are:

- It clogs drains.
- It causes water and soil pollution.

38. What are biodegradable and non- biodegradable substances? Select two biodegradable pollutants from the following: Agricultural waste, glass, plastic, sewage, DDT.

Answer. Biodegradable substances are those substances which are broken down into simpler, harmless substances in nature in due course of time by the biological processes such as micro organisms like certain bacteria.

Non-biodegradable substances are those substances which cannot be broken down into simpler, harmless substances in nature.

Two biodegradable pollutants are agricultural waste and sewage.

39. Construct an aquatic food chain showing four trophic levels.

Answer. Food chain in aquatic ecosystem:

Phytoplankton → Zooplankton → Crustacean → Fish → Crane
(Producer) (Herbivore) (Carnivore) (Carnivore) (Top Carnivore)

40. Explain 'biological magnification' with the help of an example.

Answer. Pesticides used in crops are washed down into the soil. From soil these are absorbed by plants along with water and minerals and thus, they enter the food chain. While consuming the crops, human beings also consume these pesticides which get accumulated in our bodies. This phenomenon is known as biological magnification.

41. Describe how decomposers facilitate recycling of matter in order to maintain balance in the ecosystem.

Answer. Decomposers are micro organisms that obtain energy from the chemical breakdown of dead organisms of animals or plants. These micro organisms breakdown the complex organic substances of dead organisms into simple inorganic substances that go into the soil and are used up once more by the plants. Decomposers thus, help in recycling of matter.

42. What is biodiversity? What will happen if biodiversity of an area is not preserved? Mention one effect of it.

Answer. Biodiversity is the existence of a wide variety of species of plants, animals and microorganisms in a natural habitat within a particular environment or existence of genetic variation within a species. Biodiversity of an area is the number of species or range of different life forms found there. Forests are 'biodiversity hotspots'.

Every living being is dependent on another living being. It is a chain. If biodiversity is not maintained, the links of the chain go missing. If one organism goes missing, this will affect all the living beings who are dependent on it.

43. What is meant by biodiversity? List two advantages of conserving forests and wildlife.

Answer. Biodiversity is the existence of a wide variety of species of plants, animals and microorganisms in a natural habitat within a particular environment.

Two reasons each of conserving:

(a) Forest

(i) It helps in retaining the sub-soil water.

(ii) It checks flood.

(b) Wildlife

(i) To maintain ecological equilibrium.

(ii) To protect the nature.

44. Why we say energy flow in the biosphere is unidirectional?

Answer. The energy flow through different steps in the food chain is unidirectional. This means that energy captured by autotrophs does not revert back to the solar input and it passes to the herbivores, i.e. it moves progressively through various trophic levels. Thus, energy flow from the sun through producers to consumers is in single direction only.

45. How can we help in reducing the problem of waste disposal? Give any two methods.

Answer. Problem of waste disposal can be solved by following methods:

(i) by disposing biodegradable and non-biodegradable waste separately.

(ii) by reusing materials as much as possible.

46. "Damage to the ozone layer is a cause for concern." Justify this statement. Suggest any two steps to limit this damage. '

Answer. Ozone layer prevents the harmful ultraviolet radiation to enter the atmosphere and reach the earth's surface. Depletion of ozone layer has become a cause for concern because it can cause serious effects on human body and other organisms of the environment like fatal diseases such as skin cancer, changes in genetic material DNA, eye damage, etc.

Two steps to limit this damage are as follows:

- Judicious use of aerosol spray propellants such as fluorocarbon and chlorofluorocarbons which cause depletion or hole in ozone layer.
- Control over large scale nuclear explosions and limited use of supersonic planes.

SHORT ANSWER TYPE QUESTION[II] [3 Marks]

47. (a) What is ‘environmental pollution’?

(b) Distinguish between biodegradable and non-biodegradable pollutants.

(c) Choose the biodegradable pollutants from the list given below:

Sewage, DDT, radioactive waste, agricultural waste.

Answer. (a) Environmental pollution is an undesirable change in the physical, chemical or biological

characteristics of the natural environment, brought about by man’s activities. This pollution may affect the soil, rivers, seas or the atmosphere.

(b)

Biodegradable pollutants	Non-biodegradable pollutants
(i) These pollutants can be broken-down into nonpoisonous substances in nature by the action of microorganisms.	(i) These pollutants cannot be broken-down into non-poisonous substances by microorganisms.
(ii) They get recycled thus, do not need any dumping sites.	(ii) They cannot be recycled thus, require dumping sites.
(iii) These are obtained from living things.	(iii) These are obtained from non-living things.
(iv) They cause minimum environmental pollution.	(iv) They cause environmental pollution.

(c) Biodegradable pollutants are sewage and agricultural waste.

48. **Why are bacteria and fungi called decomposers? List any two advantages of decomposers to the environment.**

Answer. Bacteria and fungi breakdown the dead remains and waste products of organisms. These micro organisms are called the decomposers as they breakdown the complex organic substances into simple inorganic substances that go into the soil and are used up once more by the plants.

Two advantages of decomposers to the environment are as follows:

- Decomposers feed, on the dead bodies of plants and animals. They return the simple components to soil and help in making the steady state of ecosystem by recycling of nutrients. They, therefore, create a balance in the environment.
- They also act as scavengers or cleansing agents of the atmosphere.

49. **Explain the phenomenon of “biological magnification” How does it affect organisms belonging to different trophic levels particularly the tertiary consumers?**

Answer. The process in which harmful chemicals enter a food chain and get accumulated progressively at each trophic level is called biological magnification.

Harmful and toxic chemicals enter our bodies when they are added to soil and water. Use of pesticides to protect the food crops from diseases and pests and chemical wastes of factories are dumped in open or disposed off into rivers. These chemicals are washed down into the soil and ultimately to water table or get absorbed or taken up from the soil by the plants along with water and minerals and in this way harmful chemicals enter the food chain. The quantity of these harmful chemicals increase with increase in trophic level of the food chain because these substances are not degradable. Man is at the top of the food chain, so concentration is maximum in human beings.

Thus, accumulation of DDT has been maximum in man as DDT is used to destroy pests. DDT is accumulated in the following way in this food chain:

This is the reason why our food grains such as wheat and rice, vegetables and fruits and even meat contain varying amounts of pesticides residues. So, the highest trophic level at the extreme right of food chain has the maximum concentration of harmful chemicals in a food chain.

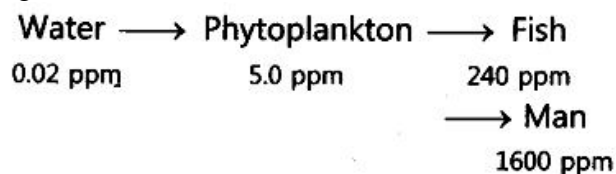

LONG ANSWER TYPE QUESTIONS [5 MARKS]

50. A non-biodegradable toxic chemical has entered into the food chain. Which type of food habit will you suggest to a man, vegetarian or non-vegetarian? Explain with the help of a food chain. The food chain which you would suggest, is advantageous in an another aspect. How?

Answer. Vegetarian food chain will be suggested in case of entry of non-biodegradable toxic chemical into the food chain.

Non-biodegradable chemical gets concentrated at every trophic level by the process of biological magnification. As the concentration increases with the number of trophic level in a food chain, man will get high concentration of the chemical in a non-vegetarian food chain than in a vegetarian food chain, e.g.

Vegetarian food chain:



Non-vegetarian food chain:

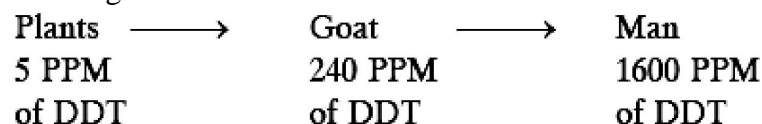

Vegetarian food chain is advantageous in terms of energy available to man because it has less number of trophic levels. As 90% of energy is lost to the environment, at every trophic level, lesser number of trophic levels will result in lesser energy loss.

51. Write a note on the producers, consumers and decomposers of the biotic environment with examples of each.

Answer.

Producers: Those organisms which produce food by photosynthesis, i.e. organisms which can make organic compounds like sugar and starch from inorganic substances using the radiant energy of the sun in the presence of chlorophyll. Producers, therefore are considered as a source of energy for those above it in a food chain.

Examples: All green plants also called autotrophs and certain blue-green algae.

Consumers: Those organisms which depend upon the producers for food, either directly or indirectly by feeding on other consumers for their sustenance. Consumers, therefore, feed upon those below it in a food chain and are called heterotrophs. These can be classified into primary consumers or herbivores, secondary consumers or small carnivores, omnivores and parasites, e.g. cows, humans.

Examples of consumers:

Herbivores are the animals that consume or eat vegetation or plants, e.g. cows, horses.

Carnivores are the animals that eat flesh of other animals, e.g. tigers, wolves.

Omnivores are the animals that eat both plants and animals, e.g. humans, cockroaches.

Parasites are those organisms that live on (ectoparasites) or in (endoparasites), the body of another organism, i.e. host from which it obtains its nutrients, e.g. parasites of man includes fleas and lice (ectoparasites), various protozoans and tapeworms. (endoparasites)

Decomposers: They are those microorganisms that obtain energy from the chemical breakdown of dead organisms or animal or plant wastes. These microorganisms are the decomposers as they breakdown the complex organic substances into simple inorganic substances that enter into the soil and are again used up by the plants.

Examples: Bacteria and fungi.

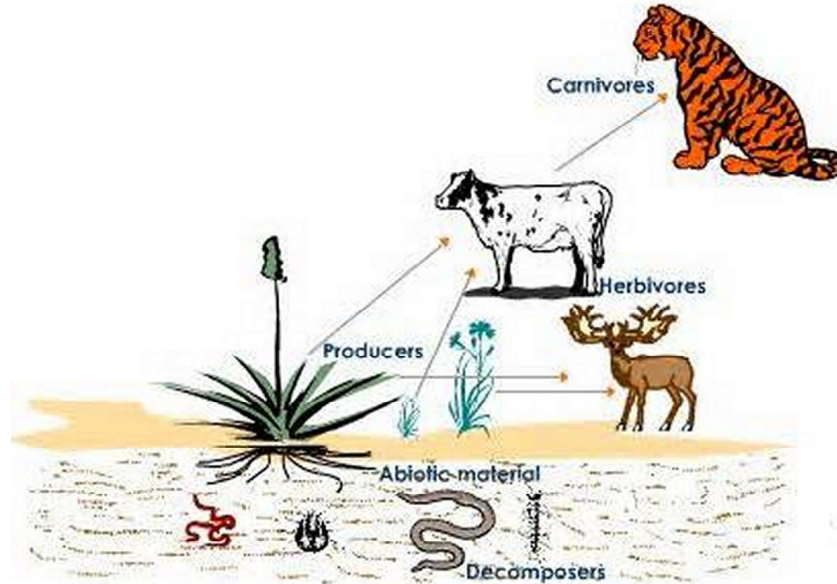

HUMAN EYE AND COLOURFUL WORLD

VERY SHORT ANSWER TYPE QUESTIONS [1 Mark]

- 1. Which phenomenon is responsible for making the path of light visible?**
Answer. Tyndall effect.
- 2. State one function of iris in human eye.**
Answer. Iris controls the size of pupil.
- 3. State one function of pupil in human eye.**
Answer. Pupil regulates and controls the amount of light entering the eye.
- 4. State one role of ciliary muscles in the human eye.**
Answer. Ciliary muscles help the eye lens to focus the image of an object on the retina by increasing or decreasing the curvature of eye lens.
- 5. State one function of the crystalline lens in the human eye.**
Answer. Crystalline (eye) lens forms a real and inverted image of the object on the retina.
- 6. State two properties of the image formed by the eye lens on the retina.**
Answer.
 - (a) Image on the retina is real and inverted.
 - (b) Diminished in size.
- 7. State one function of cornea in human eye.**
Answer. Cornea provides the refraction of light rays entering the eye.
- 8. Why does the sun appear reddish at sunrise?**
Answer. At sunrise, the sun looks almost reddish because only red colour ($\lambda_b < \lambda_r$), which is least scattered is received by our eye and appears to come from the sun. Hence, the appearance of sun at sunrise, near the horizon may look almost reddish.
- 9. What is Tyndall effect?**
Answer. The phenomenon of scattering of light by the colloidal particles is called Tyndall effect.
- 10. Give an example of optical phenomena which occurs in nature due to atmospheric refraction.**
Answer. Twinkling of stars.
- 11. Give an example of a phenomenon where Tyndall effect can be observed.**
Answer. When a fine beam of sunlight enters a room containing suspended particles of dust, the path of the beam of light is visible. It is due to the scattering of light (Tyndall effect).
- 12. Name the type of particles which acts as a prism in the formation of rainbow in the sky.**
Answer. Water droplets present in the atmosphere.
- 13. What is the cause of dispersion of white light on passing through a prism?**
Answer. The refractive index of the material of a prism is different for different colours of light as different colours have different speeds in the material of a prism. Also, prism has non-parallel surfaces.
- 14. Name the atmospheric phenomenon due to which the sun can be seen above the horizon about two minutes before actual sunrise.**
Answer. Atmospheric refraction.
- 15. Why is red colour selected for danger signal lights?**
Answer. Wavelength of red colour is more and so, it is least scattered. It can be easily seen through a large distance.
- 16. Name the part of our eyes that helps us to focus near and distant objects in quick succession.**
Answer. Ciliary muscles help in changing the focal length of the eye lens.
- 17. A person is advised to wear spectacles with concave lenses. What type of defect of vision is he suffering from?**
Answer. Myopia or short-sightedness.

18. A person is advised to wear spectacles with convex lenses. What type of defect of vision is he suffering from?
Answer. Hypermetropia or far-sightedness.
19. Why do different components of white light deviate through different angles when passing through a triangular glass prism?
Answer. Due to change in refractive index offered by the medium.
20. A person can comfortably read a book but finds it difficult to read the number on a bus parked 5 m away from him. Name the type of defect of vision he is suffering from. Which type of lens should he use in his spectacles to correct his vision?
Answer. Myopia or short-sightedness. Concave lens should be used to correct his vision.
21. What will be the colour of the sky, when it is observed from a place in the absence of any atmosphere? Why?
Answer. Sky appears dark.
Reason: In the absence of atmosphere, there would have been no scattering of sunlight at all.
22. The sky appears dark instead of blue to an astronaut. State its reason.
Answer. The sky appears dark to the astronaut as scattering does not take place at very high altitude due to the absence of atmosphere.
23. In a human eye, name the following parts:
 (a) a thin membrane which allows light to enter the eye.
 (b) the muscles which help in changing the focal length of eye lens.
Answer. (a) Cornea
 (b) Ciliary muscles
24. In which direction, the near point of hypermetropic eye is shifted from the normal near point?
Answer. The near point of hypermetropic eye is shifted farther away from the normal near point.
25. Name the component of eye that is responsible for the adjustment of eye lens?
Answer. Ciliary muscles
26. A person suffering from an eye defect uses lenses of power 1D. Name the defect he is suffering from and the nature of lens used.
Answer. Hypermetropia; convex lens.

SHORT ANSWER TYPE QUESTIONS [I] [2 Marks]

27. Name the four parts labelled as a, b, c and d in given diagram and write their functions.

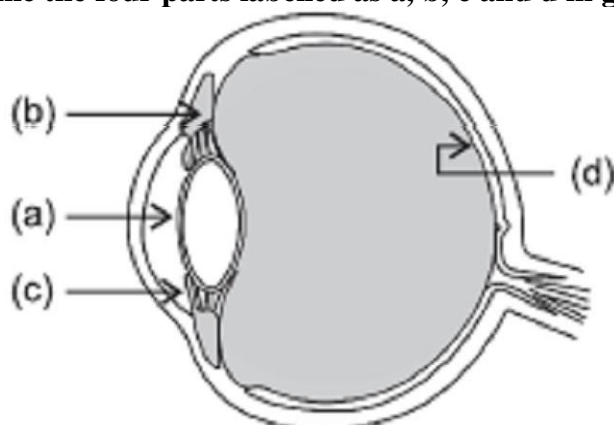

- Answer.** (a) Pupil: It controls and regulates the amount of light entering the eye.
 (b) Ciliary muscles: These muscles help to modify the curvature and there by the focal length of eye lens to focus the image of the object on the retina.
 (c) Iris: It controls the size of the pupil.
 (d) Retina: A real, inverted and diminished image of the object is formed on it.

28. What is myopia (near-sightedness)? Draw a ray diagram to show how it can be corrected using a lens.

Answer. Myopia is the inability of an eye in viewing long distant objects. The image in this case is formed before the retina. For every myopic eye, there exists a far point beyond which clear image cannot be seen.

The short-sightedness is corrected by using a concave lens which diverges and shifts the image to the retina.

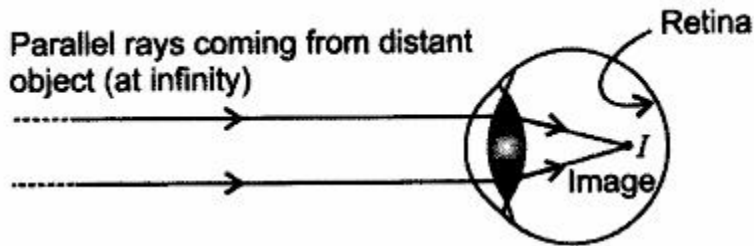

Myopic eye

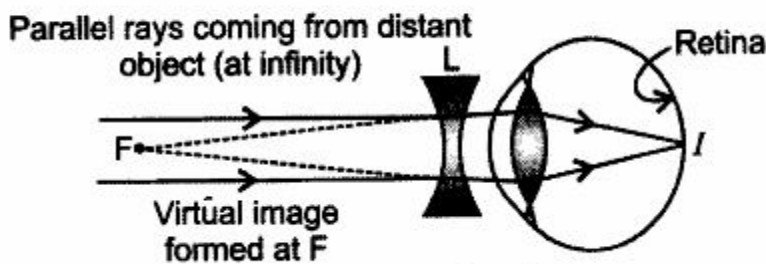

Correction of Myopia

29. What is hypermetropia (far-sighted-ness)? Draw a ray diagram to show how this defect can be corrected using a lens.

Answer. Hypermetropia is the inability of an eye in viewing the nearby objects. The image in this case is formed beyond the retina. For a hypermetropic eye, there exists a near point.

It is corrected by using a convex lens, which converges and shifts the image to the retina.

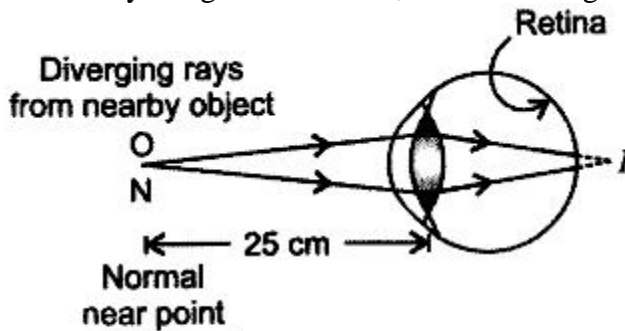

Hypermetropic eye

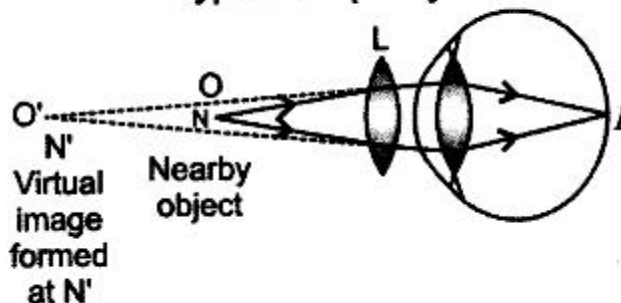

Correction of Hypermetropia

30. Define the term dispersion of white light. State the colour which bends (i) the least and (ii) the most while passing through a glass prism.

Answer. The splitting up of white light into its component colours is called dispersion. The

colour which bends (i) the least is red, and (ii) the most is violet, while passing / through a glass prism.

31. **Student sitting at the back bench in a class is not able to see what is written on the blackboard. He however, sees it clearly when sitting on the front seat at an approximate distance of 1.5 m from the blackboard. Draw ray diagrams to illustrate the image formation of the blackboard when he is seated at the (i) back seat (ii) front seat.**

Answer. (i) When student is seated at the back seat.

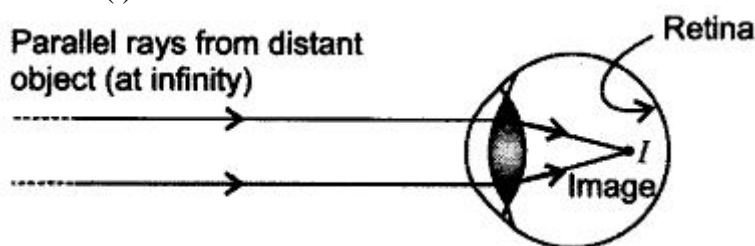

(ii) When student is seated at front seat.

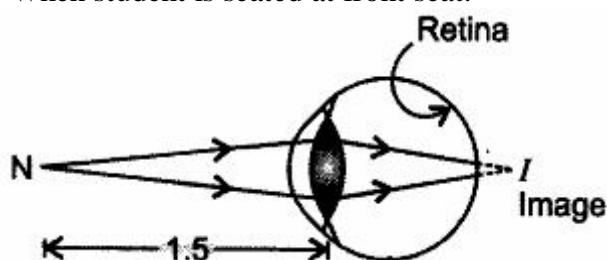

32. **What is meant by spectrum of white light? How can we recombine the components of white light after a prism has separated them? Draw a diagram to illustrate it.**

Answer. The coloured pattern VIBGYOR formed by a prism by splitting the incident white light is called a spectrum. By having two prisms, inverted to each other, one can recombine the light to get white light again.

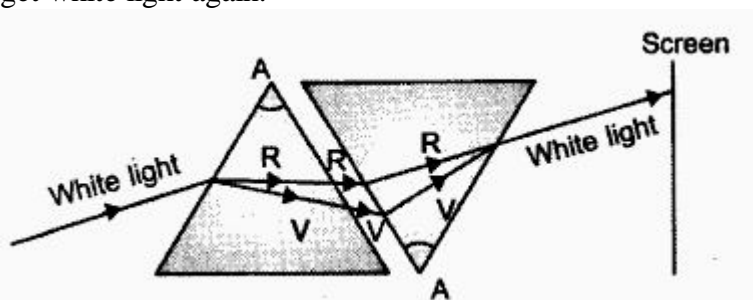

33. **Explain why do the planets not twinkle but the stars twinkle.**

Answer. Planets being of larger size can be taken as a collection of large number of point-sized objects/sources of light, which nullify the twinkling effect of each other.

Due to varying conditions of atmosphere, starlight undergoes multiple refraction and its path varying slightly while passing through the atmosphere. Therefore, the apparent position of star fluctuates and amount of light entering the eye changing continuously. The star sometimes appear brighter and some other time, it appears fainter. This causes twinkling of star.

34. **Give reasons:**

(i) **The extent of deviation of a ray of light on passing through a glass prism depends on its colour.**

(ii) **Lights of red colour are used for danger signals.**

Answer. (i) Refractive index of a medium is different for different colours of light.

(ii) Due to large wavelength, red colour is least scattered and travel to large distance.

35. **What is meant by least distance of distinct vision? How does this vary between the very young and old people ?**

Answer. The minimum distance at which an object can be seen most distinctly without strain by the eye, is termed as least distance of distinct vision.

For an infant, it is about 5 to 8 cm.

For a young adult with normal vision, it is about 25 cm.

For an old person, the power of accommodation of the eye decreases due to gradual weakening of ciliary muscles and the diminishing flexibility of the eye lens. Hence the least distance of distinct vision for him generally increases.

36. **A star appears slightly higher (above) than its actual position in the sky. Illustrate it with the help of a labelled diagram.**

Answer. The gradual change in the refractive index of different layers of the atmosphere due to the varying conditions of it causes atmospheric refraction. When starlight enters the atmosphere, it gets refracted continuously. The higher level of air acts as a rarer medium while the dense air near the surface of earth acts as a denser medium. So, the atmosphere bends the starlight towards the normal. As a result, the apparent position of star is slightly different from its actual position. Thus, star appears slightly higher (above) than its actual position in the sky.

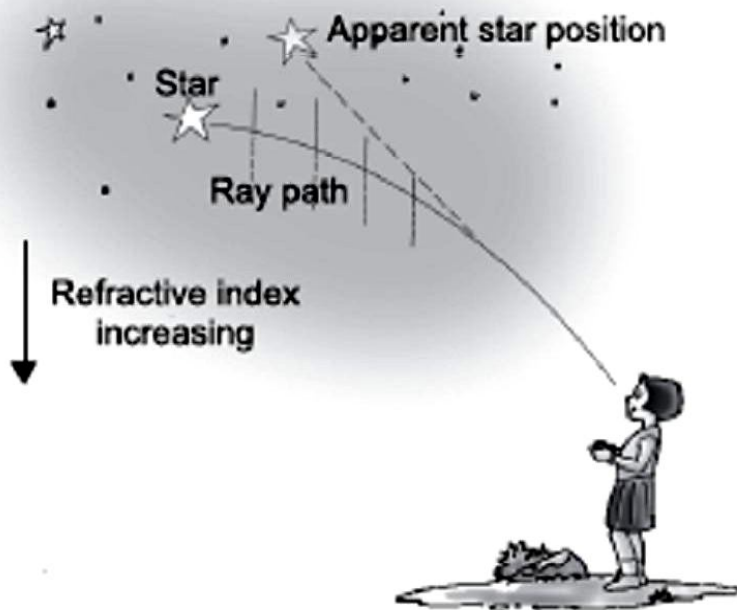

37. **Draw a ray diagram to show the refraction of light through a glass prism. Mark on it (a) the incident ray. (b) the emergent ray and (c) the angle of deviation.**

Answer. i - incident angle, r - refraction angle, δ - angle of deviation, e - angle of emergence.

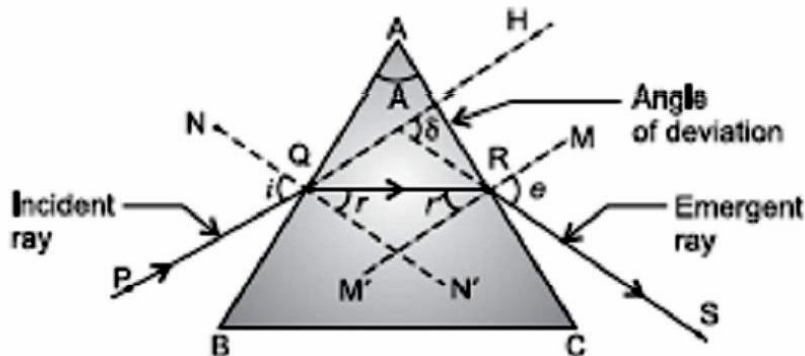

Refraction of light through a glass prism

38. **A star sometimes appears brighter and some other times fainter. What is this effect called? State the reason for this effect.**

Answer. This effect is called Twinkling effect.

Reason: It is due to atmospheric refraction of starlight. The atmosphere has varying layers. The gradual change in the refractive index of different layers of atmosphere causes atmospheric refraction and starlight undergoes multiple refraction. So, the fluctuation in the position of star occurs continuously due to the changing amount of light entering the eye. The star sometimes appears brighter and at some other times, it appears fainter. This causes twinkling of star.

39. **What is the colour of the clear sky during day time? Give reason for it.**

Answer. Clear sky appears blue.

Reason: When sunlight passes through the atmosphere having the molecules of air and other fine particles, whose size is smaller than the wavelength of visible light, these molecules and particles scatter the blue colour more strongly than the other colours of spectrum as the wavelength of blue colour is more. This scattered blue light enters our eye. So, the colour of sky appears blue to us during day time.

40. **In which of the following two cases the focal length of the eye lens will be more–**

(a) **When ciliary muscles of a normal eye is most relaxed.**

(b) **When ciliary muscles of a normal eye is in most contracted state.**

Explain with reason.

Answer. The focal length of the eye lens will be more in case (a), i.e. when ciliary muscles of a normal eye is most relaxed.

(b) Reason: When ciliary muscles are relaxed, the eye lens becomes thin. Thus, its focal length increases.

In case when ciliary muscles is in most contracted state, radius of curvature of eye lens increases. Lens becomes thicker. This decreases the focal length of eye lens.

41. **The near point of a hypermetropic eye is 50 cm. What is the nature and power of the lens required to enable him to read a book placed at 25 cm from the eye?**

Answer. Given: Object distance, $u = -25$, Image distance, $v = -50$ cm, Power of lens, $P = ?$

Using lens formula,

$$\frac{1}{f} = \frac{1}{v} - \frac{1}{u} \Rightarrow \frac{1}{f} = \frac{1}{-50} - \frac{1}{-25}$$

$$\frac{1}{f} = -\frac{1}{50} + \frac{1}{25} = \frac{1}{50}$$

or $f = +50 \text{ cm} = +0.5 \text{ m}$

The nature of lens is convex and power,

$$P = \frac{1}{f(\text{m})} = \frac{1}{0.5} = +2.0 \text{ D}$$

42. **Why does it take sometimes to see the objects in dim light when you enter the room from bright sunlight outside?**

Answer. In bright sunlight, the iris contracts the pupil to allow less light to enter the eye and in dim light, the iris expands the pupil to admit more light to see the object clearly. Therefore, it takes sometimes to increase the size of pupil in dim light.

43. **Why are we not able to see the things clearly when we come out of a darkroom?**

Answer. In dim light, the iris expands the pupil to allow more light to enter the eye. So, when we come out of a darkroom into the bright sunlight, a large amount of light enters into our eyes and due to glare feeling, we are not able to see the things clearly. Gradually, the iris contracts the pupil to allow less light to enter the eye to see the objects clearly. It take some time for the pupil. For that time interval, person is unable to see the things.

44. **What is a spectrum? Why do different coloured rays deviate differently on passing through a glass prism?**

Answer. The band of coloured component of a light beam is called its spectrum. The colour sequence is given by the acronym V I B G Y O R — Violet, Indigo, Blue, Green, Yellow, Orange and Red.

The speed of light of different colours in a medium like glass is different. Varying speeds for different colours lead to different refractive indices for different colours. It has been observed that the refractive index of glass for violet colour is more than that for red colour. All the colours present in white light refract through different angles and hence, emerge out from the prism with different directions and become distinct.

SHORT ANSWER TYPE QUESTIONS [II] [3 Mark]

45. What is meant by the term ‘power of accommodation’ of human eye? How does it help a person to see nearby as well as distant objects clearly.

Answer. The ability of eye lens to adjust its focal length to form the sharp image of the object at varying distances on the retina is called its power of accommodation.

When we see the nearby object, the ciliary muscles contract, it increases the thickness of eye lens. The eye lens then becomes thicker. As a result, the focal length of eye lens decreases in such a way that the clear sharp image of nearby object is formed on the retina. Thus, the object is seen clearly to us.

When we see the distant object, these muscles becomes relaxed, thus the eye lens becomes thinner, and consequently focal length of the lens increases. Therefore, the parallel rays coming from the distant object are focused on the retina and object is seen clearly to us. Thus, the accommodation power of an eye helps a person to see nearby as well as distant objects clearly.

46. (a) What is meant by the power of accommodation of an eye?

(b) A person with a myopic eye cannot see objects beyond 1.2 m directly. What should be the type of the corrective lens used? What would be its power?

Answer. (a) The maximum variation in power of the lens so that the far-off and nearby objects are viewed clearly is called power of accommodation.

(b) To correct, an object at infinity has to be brought as an image to 120 cm.

$$\begin{aligned} \therefore \frac{1}{f} &= \frac{1}{-120} - \frac{1}{(-\infty)} = \frac{1}{-120} \\ \Rightarrow f &= -120 \text{ cm} \\ P &= \frac{100}{-120} = \frac{-5}{6} \text{ D} \\ &= -0.83 \text{ D} \end{aligned}$$

A concave lens of focal length 120 cm and power – 0.83 D is to be used.

47. (a) What are the values of (i) near point and (ii) far point of vision of a normal adult person?

(b) A student has difficulty in reading the blackboard while sitting in the last row. What could be his defect of vision? Draw a ray diagram to illustrate this defect of vision.

Answer. (a) (i) 25 cm (ii) Infinity (∞)

(b) Short-sightedness or myopia: The image in this case forms in front of the retina.

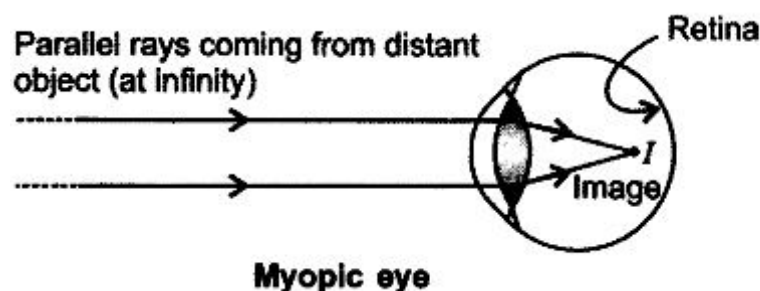

48. (a) What is meant by scattering of light?

(b) State the factors on which the colour of scattered light perceived by us depends.

Answer. (a) Scattering of Light: The phenomenon of the change in the direction of propagation of light caused by the large number of molecules, such as smoke, tiny water droplets, suspended particles of dust and molecules of air present in the earth’s atmosphere, is called scattering of light.

(b) The colour of the scattered light perceived by us depends on the size of the particles, i.e.

(i) Very fine particles scatter mainly blue colour.

(ii) Large-sized particles scatter the light of longer wavelengths.

(iii) Enough larger particles scatter the light which may appear white.

49. What is power of accommodation? How ciliary muscles help in accommodation?

Answer. The ability of eye lens to adjust its focal length to form a sharp image of the object at varying distances on the retina, is called its power of accommodation.

Help by the ciliary muscles in accommodation: When we are looking at nearby object, the ciliary muscles contract, it increases the curvature of eye lens. The eye lens then becomes thicker. As a result, the focal length of the eye lens decreases in such a way that a clear sharp image of nearby object is formed on the retina. Thus, the object is seen clearly to us.

When we are looking at distant object, these muscles are in relaxed position, the eye lens becomes thinner and the focal length of the eye lens increases. Therefore, the parallel rays coming from the distant object are focussed on the retina and the object is seen clearly to us. Thus, the accommodation power of an eye helps a person to see nearby as well as distant objects clearly.

50. Why does sun appear reddish at sunrise? Explain the help of a labelled diagram.

Answer. At the time of sunrise, sun is near the horizon, sun rays have to travel through a larger atmospheric distance. The fine particles present in the atmosphere, having size smaller than the wavelength of visible light, scattered the blue component and other smaller wavelengths present in the components of sunlight. Only red colour having longer wavelength and least scattered, reaches our eyes, hence the sun appears reddish early in the morning.

This phenomenon would not be observed on the moon due to absence of atmosphere on its surface due to which sunlight will not scatter. Therefore, the sun does not appear reddish early in the morning.

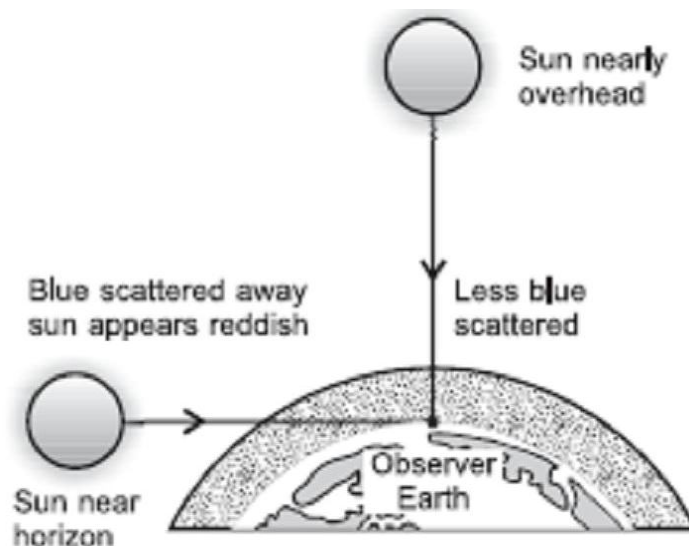

51. Explain why?

(a) A myopic person prefer to remove his spectacles while reading a book.

(b) A hypermetropic person prefer to remove his spectacles while looking at the sky.

Answer. (a) A myopic person does not need spectacles while reading a book as he has the near point at 25 cm.

If such person reads the book with corrective lens (concave) he will have to keep the book at a distance greater than 25 cm so that the image of book will be formed by the concave lens at 25 cm and moreover, the size of the book appears to him is also smaller than actual size. Therefore, the person prefer to remove his spectacles while reading a book.

(b) A hypermetropic person does not need spectacles to see distant objects as he has the far point at infinity.

If such person uses spectacles (convex lens) to see the distant objects, the image will be formed before the retina due to increase in converging power and hence the person cannot see distant objects distinctly. Therefore, such person prefers to remove his spectacles while looking at the sky.

52. Four friends went to a forest for a picnic. When they were moving around the forest, they saw that the light was filtering from the leaves of the trees. The path of the light beam becomes visible to all of them. They wondered how this happen so. Suddenly, they saw two

hunters. They immediately went to the nearest police station to complain about them. Police immediately with their force went to the forest to arrest those people.

(a) Name the effect they observed in the canopy of the dense forest and explain it.

(b) Where can you see this effect other than the forest?

(c) What can you predict about the nature and awareness of these four friends?

Answer. (a) They observed Tyndall effect in the canopy of the dense forest. The phenomenon of scattering of light by colloidal particles, present in the medium due to which the path of the beam of the light becomes visible, is called Tyndall effect.

(b) When a beam of sunlight enters a dusty room through a small hole, then its path becomes visible to us.

(c) Concern for nature, concern and affection with forest animals, helping nature.

53. Name the three common defects of vision. What are their causes? Name the type of lens used to correct each of them.

Answer. (i) **Myopia:**

Cause: Elongation of eyeball,

Type of lens used for correction: Concave lens of suitable power.

(ii) **Hypermetropia:**

Cause: Shrinking of eyeball,

Type of lens used for correction: Convex lens of suitable power.

(iii) **Presbyopia:**

Cause: Weakening of ciliary muscles,

Type of lens used for correction: Bifocal lens.

LONG ANSWER TYPE QUESTION [5 Marks]

54. A 14-year old student is not able to see clearly the questions written on the blackboard placed at a distance of 5 m from him.

(a) Name the defect of vision he is suffering from.

(b) With the help of labelled ray diagrams show how this defect can be corrected.

(c) Name the type of lens used to correct this defect.

Answer. (a) Short-sightedness (Myopia)

(b)

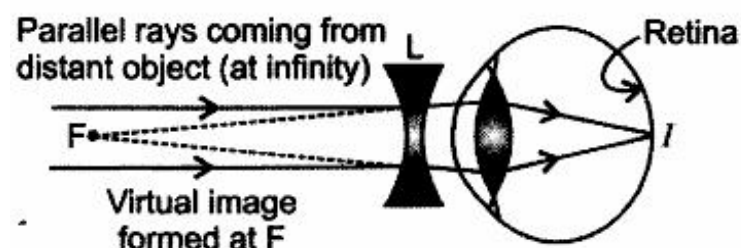
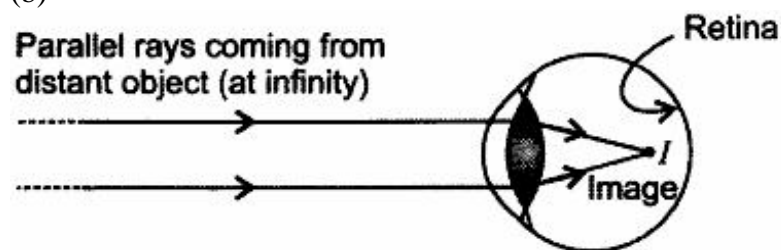

(c) Concave lens

55. (a) What is dispersion of white light? What is the cause of such dispersion? Draw a diagram to show the dispersion of white light by a glass prism.

(b) A glass prism is able to produce a spectrum when white light passes through it but a glass slab does not produce any spectrum. Explain why is it so?

Answer. (a) The splitting up of white light into its constituent colours is called dispersion. The colour sequence is given by the acronym V I B G Y O R – Violet, Indigo, Blue, Green, Yellow,

Orange and Red. This colour pattern is called a spectrum.

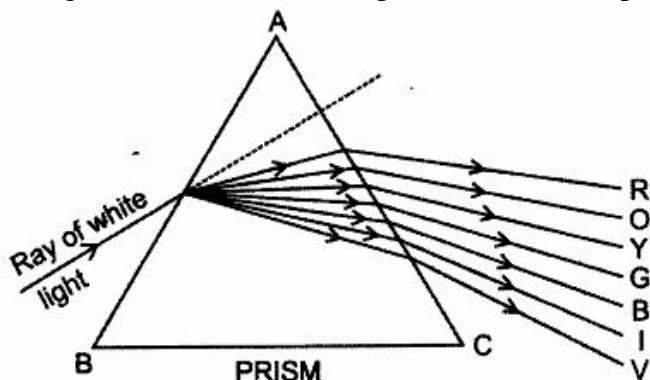

Dispersion takes place because the speed of light of different colours through a glass prism is different and so, refractive index, therefore, each colour bends (refracts) through different angles with respect to incident ray as they pass through a prism. The red colour has maximum speed in glass prism. So, it is least deviated while the violet colour has minimum speed so its deviation is maximum. Thus, the ray of each colour emerges along different paths and becomes distinct.

(b) For dispersion, the two refracting surfaces must be inclined to each other as in case of prism. In rectangular glass slab, the refracting surfaces are parallel to each other. So, dispersion cannot occur. This is due to fact that the rectangular glass slab can be considered as equivalent of two identical prisms in inverted position placed in an inverted position with respect to each other. The deviation and dispersion produced by the second inverted prism is equal and opposite to that produced by the first prism.

Therefore, there will neither be dispersion, nor deviation, i.e. second inverted prism recombines the , colour to give a white light parallel to the incident ray again and will undergo only lateral displacement. Hence, rectangular glass slab cannot produce any spectrum.

56. Study the diagram given below and answer the questions that follow it:

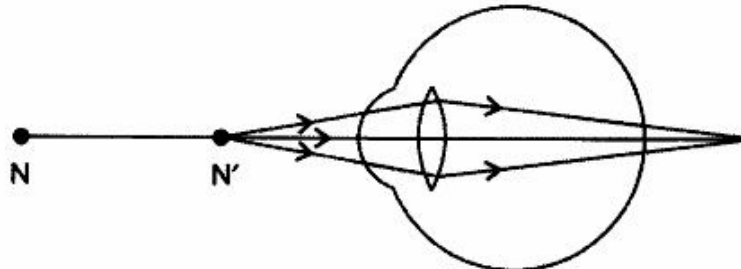

- Which defect of vision is represented in this case? Give reason for your answer.
- What could be the two causes of this defect?
- With the help of a diagram show how this defect can be corrected by the use of a suitable lens.

Answer. (a) Hypermetropia as the image is formed beyond the retina.

(b) (i) Due to greater focal length of the , lens and

(ii) As eyeball becomes smaller.

(c) It can be corrected by using a convex lens of suitable focal length as shown below.

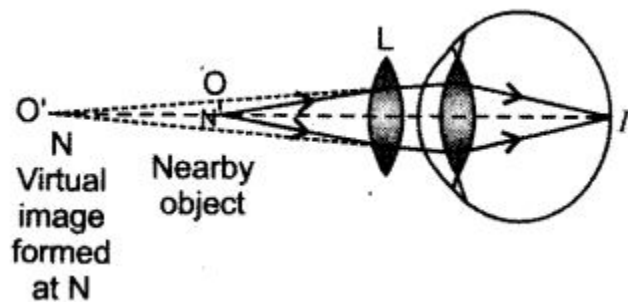

57. (a) Explain the following terms used in relation to defects in vision and correction provided by them:

(i) Myopia (ii) Astigmatism (iii) Bifocal lenses (iv) Far-sightedness.

(b) Why is the normal eye unable to focus on an object placed within 10 cm from the eye?

Answer. (a) (i) Myopia: Short-sightedness is caused due to excessive curvature in cornea or elongation of eyeball. Image is formed before of the retina. So, a concave lens is used to correct it.

(ii) Astigmatism: The inability to focus the light in both vertical and horizontal lines is called astigmatism. It is caused due to varying curvature in lens both horizontally and vertically. It is corrected by using cylindrical lens.

(iii) Bifocal lenses: These are used to correct presbyopic eye. These contain lenses with upper concave and lower convex surface. Presbyopia arises with age.

(iv) Far-sightedness: Hypermetropia or far-sightedness is caused due to greater focal length of eye lens and/or when eyeball becomes smaller. Image is formed beyond the retina and can be corrected using a convex lens.

(b) The focal length of the lens cannot be changed up to an extent that objects nearer than 25 cm can be viewed (its near point is 25 cm). So it is not able to focus for 10 cm.

58. (i) Draw a figure which shows the arrangement for observing the phenomenon of scattering of light in the laboratory.

(ii) What colours would you observe in the experiment? Why?

Answer. (i) An arrangement for observing the scattering of light in the laboratory is as shown below.

(ii) (a) On the screen, first orange red colour and then bright crimson red colour patch is observed.

(b) From the other three sides of colloidal solution of sulphur in a glass tank (T), blue colour is observed.

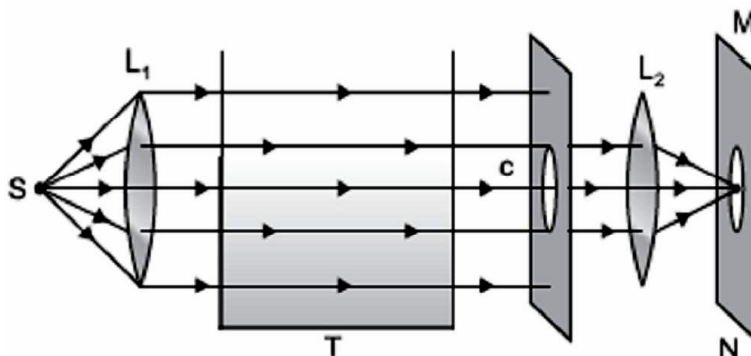

This is because the very fine colloidal sulphur particles scatter away the blue colour from the path of beam and only red colour (least scattered) of the beam of white light reaches the screen through the solution.

59. What is atmospheric refraction? Use this phenomenon to explain the following natural events.

(a) Twinkling of stars

(b) Advanced sunrise and delayed sunset.

Draw diagrams to illustrate your answers.

Answer. Atmospheric Refraction: The refraction of light caused by the earth's atmosphere due to gradual change in the refractive indices of its different layers by the varying conditions of it, is called atmospheric refraction.

(a) Twinkling of stars

Refer Q. No. 36

(b) Advanced sunrise and delayed sunset

The sun is visible 2 minutes before sunrise and 2 minutes after sunset because of atmospheric refraction. This can be explained as below.

The figure shows the actual position of the sun S at the time of sunrise or sunset, just below the horizon while the apparent position S', above the horizon as appear to us.

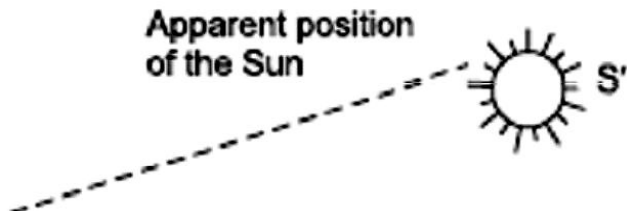

60. (a) A student cannot see clearly a chart hanging on a wall placed at a distance 3 m from his eye. Name the defect of vision he is suffering from. Draw a ray diagram to illustrate this defect. List its two possible causes.
 (b) Draw a ray diagram to show how this defect may be corrected using a lens of appropriate focal length.
 (c) An eye donation camp is being organised by social workers in your locality. How and why would you help in this cause?

Answer. (a) Myopia or Short-sightedness is the inability of an eye in viewing long distance objects. The image in this case falls before the retina. For every myopic eye, there exists a far point beyond which clear image cannot be seen. Short-sightedness is caused due to
 (i) excessive curvature in cornea. (ii) elongation of eyeball.
 (b) The short-sightedness is corrected by using a concave lens which diverges and shifts the image to the retina.

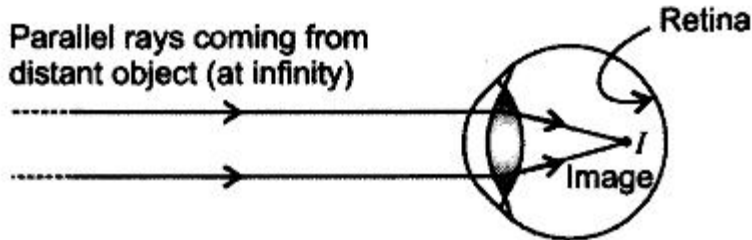

In a myopic eye, image of distant object is formed in front of the retina (and not on the retina)

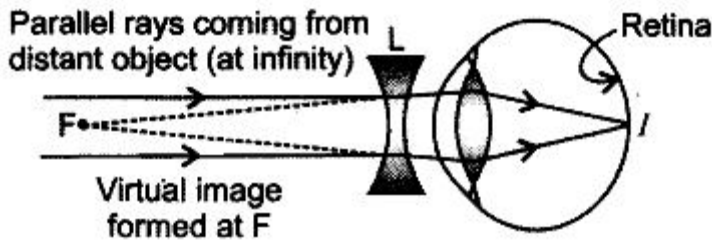

Correction of Myopia. The concave lens placed in front of eye forms a virtual image of distant object at far point (F) of the myopic eye.

(c) **Reasons for donating eyes:**

1. A person's corneal blindness can only be elevated by a human donor's cornea.
2. It is opportunity to restore someone's sight.

Methods for supporting this cause:

1. Make it a family tradition of donating the eyes.
2. Motivate and educating others about eye donation.
3. Help removing all the myths . about eye donation.

MAGNETIC EFFECTS OF ELECTRIC CURRENT

VERY SHORT ANSWER TYPE QUESTION [1 MARK]

1. Name the type of current: (a) used in household supply. (b) given by a cell.

Answer. (a) Alternating current. (b) Direct current.

2. State the observation made by Oersted on the basis of his experiment with current carrying conductors.

Answer. The electric current passing through a conducting wire produces magnetic effect.

3. Name the device which is used to draw magnetic field lines.

Answer. Compass needle.

4. Identify the poles of the magnet in the given figure.

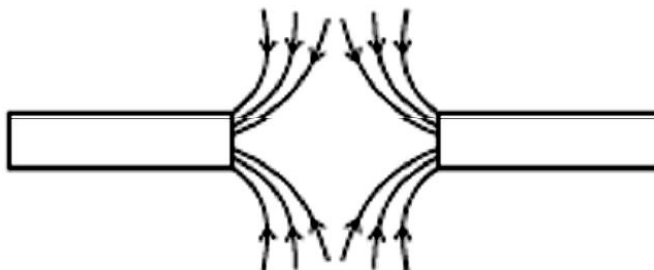

Answer. Both the poles facing each other represent south pole in nature as the magnetic field lines outside the magnet move from North to South Poles.

5. State the direction of magnetic field in the following case.

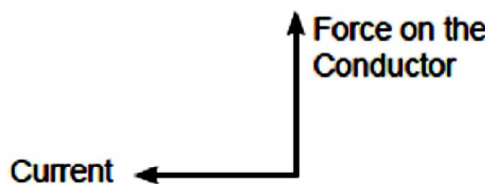

Answer. In given situation, according to Fleming's Left-Hand Rule Force is along y-axis. Current is along x-axis. Then magnetic field is along z-axis.

6. State the direction of magnetic field in the following case.

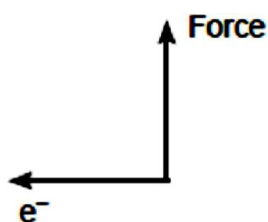

Answer. Perpendicular to the plane of paper in the outward direction by using Fleming's left hand rule.

7. Give one application of electromagnetic induction.

Answer. This phenomenon is used in electric generator.

8. Name the physical quantities which are indicated by the direction of thumb and forefinger in the Fleming's right hand rule?

Answer. In Fleming's right hand rule, thumb indicates — direction of motion of the conductor; forefinger indicates — direction of magnetic field.

9. A positively charged particle (alpha-particle) projected towards west is deflected towards north by a magnetic field. The direction of magnetic field is

(a) towards north (b) towards east
(c) downward (d) upward

Answer. (d) Upward (Apply Fleming's left hand rule).

10. The diagram shows a coil of wire wound on a soft iron core forming an electromagnet. A current is passed through the coil in the direction indicated by the arrows. Mark the N and S poles produced in the iron core.

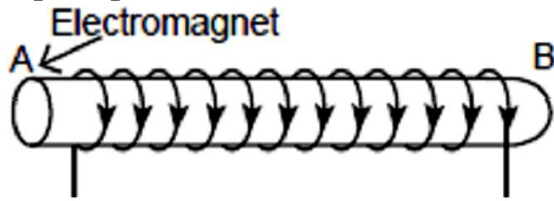

Answer. Using clock face rule
A is South pole. B is North pole.

11. How will you determine the direction of the magnetic field due to a current-carrying solenoid in the below diagram?

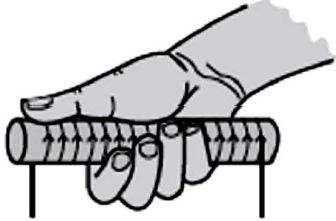

Direction of magnetic field produced by anticlockwise current in a solenoid

Answer. Direction of magnetic field: Imagine the current carrying solenoid in your right hand such that the curled fingers are in the direction of current, then the extended thumb will indicate the direction of emerging magnetic field line, i.e. the face of solenoid which has North polarity.

12. A steady current of 5 A is flowing through a conductor AB. Will the current be induced in the circular wire of radius 1m?

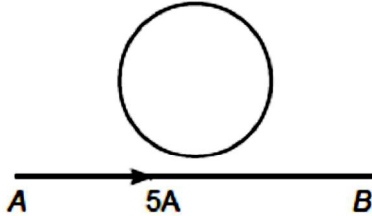

Answer. No, because circular coil is placed in a constant magnetic field produced by a steady current of 5A.

13. Name the device used to prevent damage to the electrical appliances and the domestic circuit due to overloading.

Answer. Electric fuse.

14. Give one difference between the wires used in the element of an electric heater and in a fuse.

Answer. Electric wire used in electric heater has a high melting point whereas fuse wire has a low melting point.

15. The diagram shows a beam of electrons about to enter a magnetic field. The direction of the field is into the page.

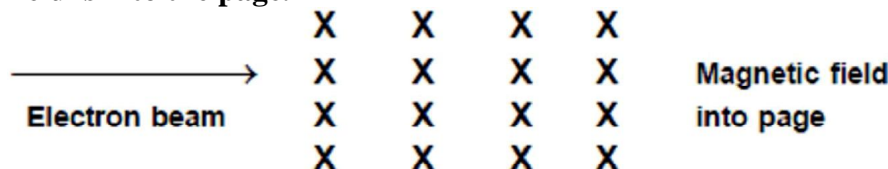

What will be the direction of deflection, if any, as the beam passes through the field?

Answer. Direction of current is from right to left as electron beam enters from left to right and magnetic field is into the page. So, according to Fleming's left hand rule, force is perpendicular to the flow of current and in its left side. So, electron beam deflects towards bottom of the page.

16. How can you show that the magnetic field produced by a given electric current in the wire decreases as the distance from the wire increases?

Answer. The decrease in deflection of the magnetic compass needle clearly shows that the magnetic field decreases as we move away from the current-carrying conductor.

17. A current carrying straight wire held perpendicular to the plane of paper and current passes through this conductor in the vertically upward direction. What is the direction of magnetic field produced around it?

Answer. According to right-hand thumb rule, the direction of magnetic field produced around the given conductor is anticlockwise.

18. If the circular coil has n turns, the field produced is n times as large as that produced by a single turn. Justify it.

Answer. This is because the current in each circular turn has the same direction, and the field due to each turn then just adds up along the axis of the coil

19. Name any two appliances which are based on the application of heating effect of electric current.

Answer. Room heater and geyser.

20. An electron beam is moving vertically upwards. If it passes through a magnetic field which is directed from south to north in a horizontal plane, then in which direction will the beam deflect?

Answer. Using Fleming's Left-Hand Rule, electron beam will be deflected towards the west.

21. A charged particle enters at right angle into a uniform magnetic field as shown. What should be the nature of charge on the particle if it begins to move in a direction pointing vertically out of the page due to its interaction with the magnetic field?

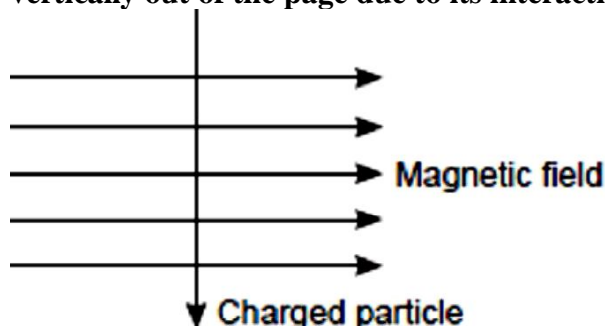

Answer. Using Fleming's left hand rule, the nature of charged particle is positive.

SHORT ANSWER TYPE QUESTIONS [I] [2 MARKS]

22. The given magnet is divided into three parts A, B, and C.

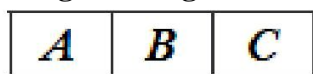

Name the parts where the strength of the magnetic field is: (i) maximum (ii) minimum.

How will the density of magnetic field lines differ at these parts?

Answer.

(i) Maximum strength – at A and C

(ii) Minimum strength – at B

At A and C, magnetic field lines are crowded while at B, they are spread out.

23. A compass needle is placed near a current-carrying wire. State your observation for the following cases, and give reason for the same in each case.

(a) Magnitude of electric current in the wire is increased.

(b) The compass needle is displaced away from the wire.

Answer.

(a) **Observation:** The deflection of the needle increases.

Reason: Magnetic field strength due to current-carrying wire increases as current in the wire

increases, $B \propto I$.

(b) Observation: The deflection in the compass needle decreases as its displacement from the current-carrying wire increases.

Reason: The strength of magnetic field reduces with the increase in distance from the wire as $B \propto \frac{1}{r}$.

24. (a) Two magnets are lying side by side as shown below.

Draw magnetic field line between poles P and Q.

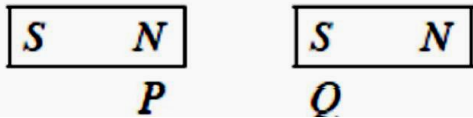

(b) What does the degree of closeness of magnetic field lines near the poles signify?

Answer. (a)

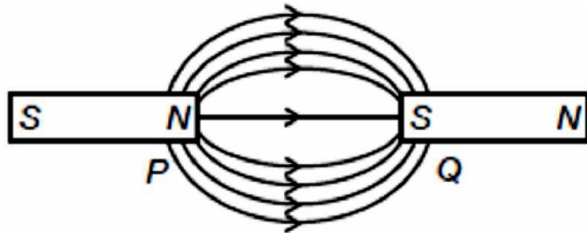

(b) The degree of closeness of magnetic field lines near the poles signify that the field is stronger there, i.e. the pole of another magnet when placed in the magnetic field experiences a greater force where the field lines are crowded.

25. Magnetic field lines of two magnets are shown in fig. A and fig. B.

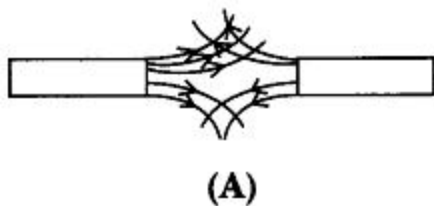

(A)

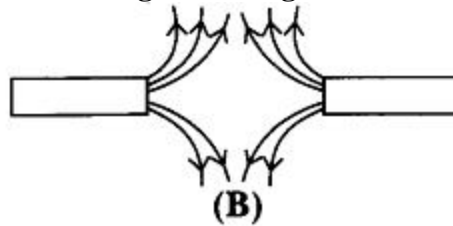

(B)

Select the figure that represents the correct pattern of field lines. Give reasons for your answer. Also name the poles of the magnets facing each other.

Answer. Figure B represents the correct pattern of field lines. In figure A, field lines cross each other which is not possible because if they cross each other, at the point of intersection, there would be two directions of field lines.

In figure B, field lines are emerging in nature, so poles of magnet facing each other are north poles while opposite faces will have south polarity.

26. Insulation cover of which colour is conventionally used for earth wire? Why is an earth wire connected to metallic parts of appliances?

Answer. For earth wire, green or yellow colour insulation is used. The earth wire provides the low resistance conducting path for the current and maintains the potential of appliances body with that of the earth. So, earth wire is used as a safety measure.

27. Identify the poles of the magnet in the given figure (1) and (2).

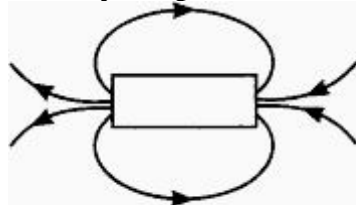

Figure (1)

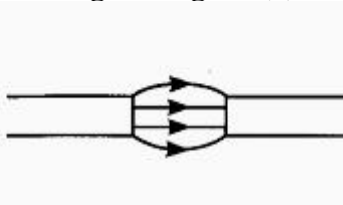

Figure (2)

Answer. Field lines emerge from north pole (N) and merge at the south pole (S) as shown in both

the figures

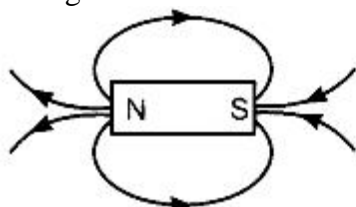

Figure (1)

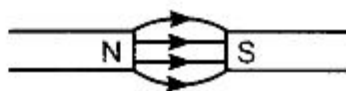

Figure (2)

28. **Explain the role of fuse in series with any electrical appliance in an electric circuit. Why should a fuse with defined rating for an electric circuit not be replaced by one with a larger rating?**

Answer. Fuse is a safety device connected in series with live wire or with any electrical appliance in an electric circuit. It stops the flow of unduly high electric current in the circuit by getting melted due to rise in temperature as per Joule's law of heating.

High rating fuse wire has the larger capacity. So, it will not stop the flow of any relatively high current. Therefore, electrical devices cannot be protected from the possible damage.

29. **The magnetic field associated with a current-carrying straight conductor is in anticlockwise direction. If the conductor was held along the east-west direction, what will be the direction of current through it? Name and state the rule applied to determine the direction of current.**

Answer. Direction of current – east to west as determined by Right-hand thumb rule. Right-hand Thumb Rule: If we hold a current-carrying conductor by right hand in such a way that the stretched thumb is along the direction of current, then the curly fingers around the conductor represents the direction of field lines of magnetic field.

30. **Two circular coils A and B are placed close to each other. If the current in the coil A is changed, will some current be induced in the coil B? Give reason.**

Answer. Yes, when a current in coil A changes, magnetic field lines linked with coil B also change. Hence, due to change in number of magnetic field lines, there is an induced current in coil B.

31. **A coil of insulated wire is connected to a galvanometer. What would be seen if a bar magnet with its north pole towards one face of the coil is**

- (i) moved quickly towards it,
- (ii) moved quickly away from the coil and
- (iii) placed near its one face?

Name the phenomenon involved.

Answer.

(i) Deflection in the galvanometer needle will be more on right-side.

(ii) Larger deflection in opposite direction as compared to the case (i) will be seen. (iii) No deflection.

The phenomenon involved is electromagnetic induction.

32. **Two coils A and B of insulated wires are kept close to each other. Coil A is connected to a galvanometer while coil B is connected to a battery through a key. What would happen if (i) a current is passed through coil B by plugging the key, and (ii) the current is stopped by removing the plug from the key?**

Explain your answer mentioning the name of the phenomenon involved.

Answer. In both the given cases, galvanometer shows momentary deflection but in opposite direction. In coil A, magnetic field lines [increased in case (i) and decreased in case (ii)] induce a potential difference across the coil A which sets up induced electric current in coil A. It is shown by the deflection in galvanometer. This is known as electromagnetic induction.

33. **An electric oven of 2 kW power rating is operated in a domestic electric circuit (220.V) that has a current rating of 5 A. What result do you expect? Explain.**

Answer. Current drawn by electric oven

$$I = \frac{P}{V} = \frac{2000 \text{ W}}{220 \text{ V}} = 9.09 \text{ A}$$

Current rating of the circuit = 5 A

So, fuse will blow off and power supply will cut off

34. **When is the force experienced by a current-carrying conductor placed in a magnetic field largest?**

Answer. When the length of current-carrying conductor and direction of magnetic field are perpendicular to each other, the maximum force is experienced by the current-carrying conductor.

35. **Why and when does a current carrying conductor kept in a magnetic field experience force? List the factors on which direction of this force depends?**

Answer. The drifting of free electrons of a conductor in a definite direction causes the current to flow through it. When such conductor is placed in a uniform magnetic field, each drifted electron of a conductor experience a magnetic force. This force is collectively experience by a conductor as a whole. Hence a current carrying conductor kept in a magnetic field experience a force. The direction of magnetic force depends on

- (i) direction of current through the conductor, and
- (ii) direction of magnetic field.

36. **How is the strength of magnetic field near a straight current-conductor (i) related to the strength of current in the conductor? (ii) is affected by changing the direction of flow of current in the conductor?**

Answer.

- (i) The strength of magnetic field around a straight current conductor increases on increasing the strength of current in the conductor or vice versa.
- (ii) The direction of magnetic field around a straight current carrying conductor gets reversed if the direction of current through that conductor is reversed.

37. **List in tabular form two major differences between an electric motor and a generator.**
Answer.

Electric motor	Electric Generator
(i) It converts electrical energy into mechanical energy.	(i) It converts mechanical energy into electrical energy.
(ii) It works on the principle of magnetic effect of electric current, i.e. when a current carrying conductor is placed perpendicular to the direction of magnetic field, it experiences a force. The direction of force can be found by using the Fleming's Left-Hand Rule.	(ii) It is based on the electromagnetic induction, i.e. current can be induced in a coil by rotating it in a magnetic field. The direction of induced current can be found by using the Fleming's Right-Hand Rule.
(iii) Armature is rotated in the magnetic field by supplying electric current to it by some external source such as battery to get the mechanical work.	(iii) Armature is rotated in the magnetic field by some external mechanical force to produce electric current.
(iv) Split ring is used as a commutator to reverses the direction of flow of current and direction of force acting on the arms of the coil after every half of its rotation. This make the coil to continue rotate in the same direction.	(iv) The slip rings conduct the alternating current or split ring conduct the direct current to the external circuit through the carbon brushes.

38. **Explain any two situations that can cause electrical hazards in domestic circuits.**

Answer. (i) Connecting too many electrical devices to a single socket or in the extension cord for any length of time draws high current from the mains that will exceed the current rating of connecting wires. The wires cannot withstand such a high current and melt and may cause fire.
(ii) Most electrical hazards in domestic circuits are caused by the faulty electrical outlets, old and out-dated appliances. The chances of short circuit i.e., contact of live wire and neutral wires with

each other due to damage in their insulation or some fault in the appliances are very high. It may result spark at the contact point which may even cause fire,

39. How does the power of electric motor be enhanced?

Answer. The power of electric motor can be enhanced by

- (i) using an electromagnet in place of permanent magnet.
- (ii) increasing the number of turns in the coil and
- (iii) using a soft iron core on which the coil is wound.

40. What is meant by the term 'frequency of an alternating current'? What is its value in India? Why is an alternating current considered to be advantageous over direct current for long range transmission of electric energy?

Answer.

- Frequency of Alternating current is equal to the number of cycles completed in one second.
- In India, frequency of AC is 50 Hz i.e. 50 cycles per second.
- An alternating current is considered to be advantageous over direct current for long range transmission of electric energy because it can be transmitted over long distances to distant places without much loss of electric power as compared to direct current.

SHORT ANSWER TYPE QUESTIONS [II] [3 MARKS]

41. What is short circuiting? State one factor/condition that can lead to it. Name a device in the household that acts as a safety measure for it. State the principle of its working.

Answer. Short circuiting: When electric circuit offers very low resistance to the flow of current through it, the current increases heavily and the circuit is said to be short circuited. It occurs when live wire touches the neutral wire. This happens due to the damage in insulation of the power lines.

Safety measure device: Fuse.

Working principle of fuse: It works on the heating effect of electric current or Joule's law of heating. According to this law, the heat produced in a resistor is directly proportional to the

- (i) square of current for a given resistance.
- (ii) resistance for a given current and
- (iii) time for which the current flows through the resistor.

$$H = I^2Rt$$

So, when current in the circuit increases, the wire with low melting point in it melts to the heat generated. Hence, the circuit breaks and electrical devices and appliances are saved. _

42. Write one application of each of the following:

- (a) Right-hand thumb rule**
- (b) Fleming's left hand rule**
- (c) Fleming's right hand rule**

Answer.

(a) Right-hand thumb rule is used to find the direction of magnetic field in a coil of wire and the electric current in a straight conductor.

(b) Fleming's left hand rule is used to find the direction of force exerted on a current-carrying conductor placed in a magnetic field as in electric motor.

(c) Fleming's right hand rule is used to find the direction of induced current in a closed circuit placed in changing magnetic field as in electric generator.

43. State one main difference between A.C. and D.C. Why is A.C. preferred over D.C. for long range transmission of electric power? Name one source each of D.C. and A.C.

Answer. Difference between A.C. and D.C.: The alternating current (A.C.) reverses its direction periodically whereas the direct current (D.C.) always flows in one direction.

A.C. is preferred over D.C. because it can be transmitted over long distance without much loss of energy.

D.C. source: Battery

A.C. source: A.C. generator

44. **How will the magnetic field produced at a point due to a current-carrying circular coil change if we:**

(i) increase the current flowing through the coil?

(ii) reverse direction of current through the coil?

(iii) increase the number of turns in the coil?

Answer. Magnetic field (B) at the centre of the circular coil

(i) increases if the current is increased as $B \propto I$

(ii) reverses on reversing the current. .

(iii) increases if the number of turns in the coil increases as field is directly proportional to the number of turns.

45. **(a) Mention the factors on which the direction of force experienced by a current-carrying conductor placed in a magnetic field depend.**

(b) Under what condition is the force experienced by a current-carrying conductor placed in a magnetic field maximum?

(c) A proton beam is moving along the direction of a magnetic field. What force is acting on proton beam?

Answer. (a) The direction of force experienced by the current-carrying conductor depends on:

(i) direction of current and

(ii) direction of magnetic field.

(b) When the direction of current is at right angle to the direction of magnetic field, the force is maximum.

(c) No force is experienced by the proton beam. As proton beam is moving along the direction of magnetic field.

46. **A coil of insulated copper wire is connected to a galvanometer. What will happen if a bar magnet is (a) pushed into the coil,**

(b) withdrawn from inside the coil,

(c) held stationary inside the coil?

Answer.

(a) When a bar magnet is pushed into the coil, magnetic field lines linked with the coil changes (increases). It causes the electric current to get induced in it. The needle of galvanometer will move momentarily in one direction.

(b) When a bar magnet is withdrawn from inside the coil, the magnetic field lines linked with the coil changes but in decreasing order. Current will be induced in the coil which will be indicated by deflection of needle in the galvanometer. The deflection is opposite to that in case (a). This indicates that the direction of induced current is now opposite to the direction of induced current in case (a).

(c) When bar magnet is held stationary inside the coil, there is no deflection in the galvanometer. This is because there is no change in magnetic field lines linked with the coil. Hence, no induced current will flow through the coil.

47. **State the rule to determine the direction of a**

(a) magnetic field produced around a straight conductor carrying current,

(b) force experienced by a current-carrying straight conductor placed in a magnetic field which is perpendicular to it.

Answer.

(a) Direction of magnetic field produced around a straight current-carrying conductor is given by right-hand thumb rule.

If we hold a current-carrying conductor in a right hand in such a way that the stretched thumb is along the direction of current, then the curly fingers around the conductor represent the direction of magnetic field lines.

(b) Direction of force experienced by a current-carrying straight conductor placed in a magnetic field which is perpendicular to it, is given by Fleming's left hand rule.

Stretch the thumb, forefinger and middle finger of left hand in such a way that they are mutually perpendicular to each other. If the forefinger points to the direction of magnetic field and the

middle finger points to the direction of current, then the thumb will point to the direction of motion or the force acting on the conductor.

48. **State one main difference between A.C and D.C. Why A.C is preferred over D.C for long range transmission of electric power? Name one source each of D.C and A.C.**

Answer. Difference between A.C. and D.C. The alternating current (A.C.) reverses its direction periodically whereas the direct current (D.C.) always flows in one direction.

A.C. is preferred over D.C. because it can be transmitted over long distance without much loss of energy.

D.C. source : Battery, A.C. source : A.C. generator

49. **The direction of electric current passed through a vertical wire and through a horizontal card is shown below:**

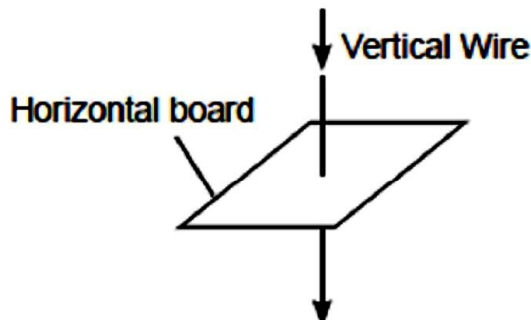

Sketch the pattern of the magnetic field on the card around the wire. Indicate the direction of the magnetic field at any one point. How would you check this direction experimentally?

Answer. The pattern of magnetic field lines on the card around the current carrying conductor for the downward direction of current is shown. They are concentric in circle with their centre ties on the axis of wire.

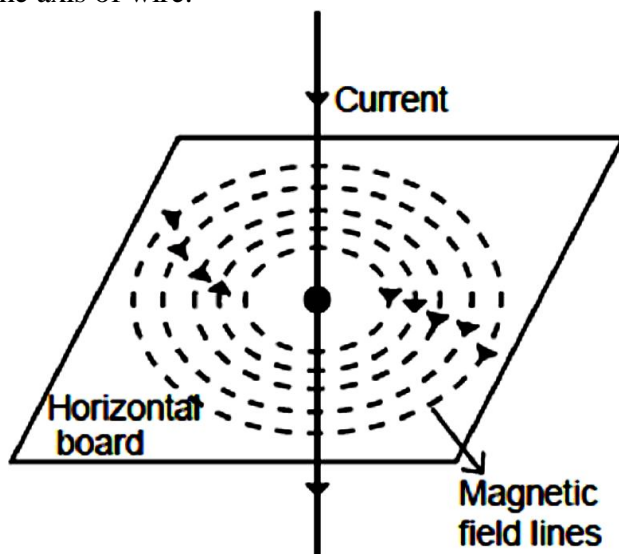

Direction of magnetic field lines can be checked experimentally by placing a magnetic compass needle any where on the card board. Direction of its North pole indicating the direction of magnetic field.

50. **State the consequences that can lead to a short circuit. OR One of the major cause of fire in office building is short circuiting. List three factors which may lead to the short circuit.**

Answer. It occurs as a consequence of

- failure of electrical insulation's due to which live wire comes in direct contact with neutral or earth wire.
- presence of external conducting material such as water which is introduced accidentally into the circuit.
- electrical appliances are forced to operate when its moving parts are jammed.

- connection of current carrying parts of electrical equipment's comes in contact to one another due to human or natural cause and
- use of less rating wires.
When this happens, there is an excessive electric current which can damage the circuit and may also cause electrical fires.

51. **What is meant by solenoid? How does a current carrying solenoid behave? Give its main use.**

Answer. Solenoid: A coil of many circular turns of insulated copper wire wound on a cylindrical insulating body (i.e., cardboard etc.) such that its length is greater than its diameter is called solenoid.

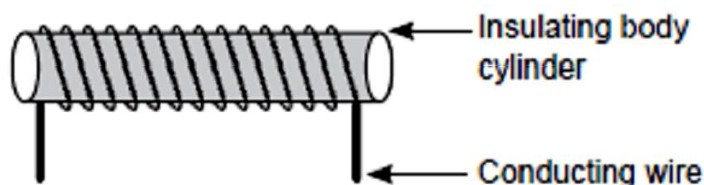

When current is flowing through the solenoid, the magnetic field line pattern resembles exactly with those of a bar magnet with the fixed polarity, i.e. North and South pole at its ends and it acquires the directive and attractive properties similar to bar magnet. Hence, the current carrying solenoid behave as a bar magnet.

Use of current carrying solenoid: It is used to form a temporary magnet called electromagnet as well as permanent magnet.

52. **For the current carrying solenoid as shown below, draw magnetic field lines and giving reason explain that out of the three points A, B and C at which point the field strength is maximum and at which point it is minimum.**

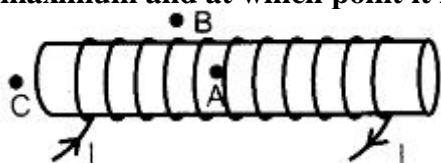

Answer. Outside the solenoid magnetic field is minimum. At the ends of solenoid, magnetic field strength is half to that inside it. So Minimum – at point B; Maximum – at point A

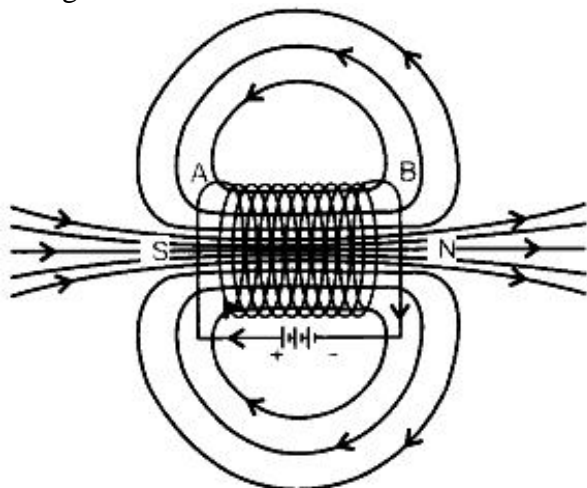

53. **With the help of a diagram of experimental setup describe an activity to show that the force acting on a current carrying conductor placed in a magnetic field increases with increase in field strength.**

Answer.

Aim : To show that force acting on a current carrying conductor placed in a magnetic field increases with the field strength.

Apparatus Required : Aluminium rod, stand horse shoe magnet of different intensity, cell, key and connecting wires.

Procedure :

- i) Arrange the set-up as shown in figure.

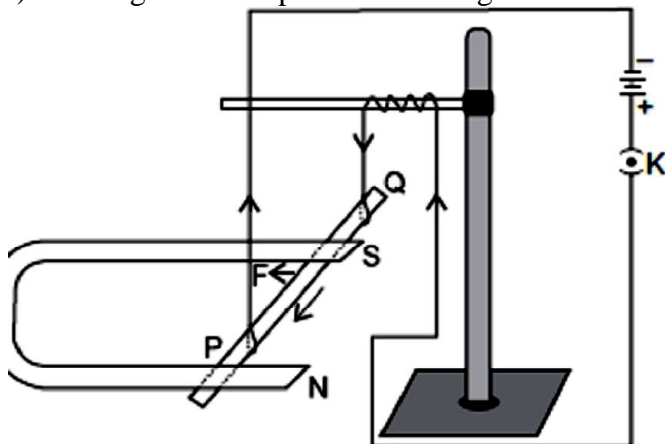

A current carrying rod, PQ is experiencing force F

- ii) Plug the key, the current flowing through the rod from Q to P observe the displacement of rod.
 iii) Now unplug the key and remove the first horse shoe magnet and place the second horse shoe magnet of higher magnetic field strength in a similar manner to that of first.
 iv) Plug the key, the current again flow through the rod from Q to P. Again observe the deflection of rod.
 v) Now bring both the magnet closer together (to ensure greater magnetic field than that of previous case). Again observe the motion of rod.

Observations : Each time, the conductor moves faster than that of previous one. It is possible only when conductor gets accelerated more each time which required more force. ($F = ma$) Thus, if the magnetic field strength is increased, the rod will experience a greater force and move faster.

Conclusion : The force acting on a current carrying conductor placed in a magnetic field increases with increase in field strength.

54. What are magnetic field lines? Justify the following statements

- (a) **Two magnetic field lines never intersect each other.**
 (b) **Magnetic field lines are closed curves.**

Answer.

Magnetic field lines: It is defined as the path along which the unit North pole (imaginary) tends to move in a magnetic field if free to do so.

- (a) The magnetic lines of force do not intersect (or cross) one another. If they do so then at the point of intersection, two tangents can be drawn at that point which indicates that there will be two different directions of the same magnetic field, i.e. the compass needle points in two different directions which is not possible.
 (b) Magnetic field lines are closed continuous curves. They diverge from the north pole of a bar magnet and converge its south pole. Inside the magnet they move from south pole to north pole.

55. What is overloading? State the causes of overloading.

Answer. Overloading: If the current drawn by the many electrical appliances connected to a single socket exceeds the current rating of the wire, the entire circuit or part of circuit gets heated and can even cause fire. This is known as overloading.

It might be due to

- (i) accidental hike in supply voltage or
 (ii) connecting too many appliance to a single socket or
 (iii) damage in the insulation of wires or
 (iv) some fault in the appliances or
 (v) direct contact between a live wire and a neutral wire.

56. Give scientific reasons.

(a) Wires carrying electricity should not be touched when bare-footed.

(b) We must not use many electrical appliances simultaneously.

(c) Electrical switches should not be operated with wet hand.

Answer. (a) When we touch the live wire bare-footed, our body is directly in contact with the earth. So, current passes through the body to the earth. As our body is good conductor of electricity, we get a severe shock. Hence, we should not handle live wires bare footed.

(b) When many high power rating appliances are switched on simultaneously, a large amount of current flows through the main circuit and current may exceed the bearing capacity of the connecting wires. This causes overloading, which may cause fire. Hence, we must not use many electrical simultaneously.

(c) Switches should not be operated with wet hand : Water is a good conductor of electricity as it contains salt and impurities. When we touch the switch with wet hand, it is possible that electric current will pass through our body and we get a severe shock.

57. Describe an activity to show that the magnetic field lines produced when current is passed through the circular coil.

Answer.

Aim : To study the characteristics of magnetic field produced by a current carrying circular coil at its centre.

Apparatus Required : Rectangular cardboard having two holes, Thick copper circular coils of different radii having known number of turns, key, battery, rheostat, stand, iron filings.

Procedure :

- i) Pass the coil through the two holes of cardboard in such a way that half of the loop is above the cardboard and remaining part should be below it and normal to the plane of cardboard.
- ii) Connect the circuit as shown.

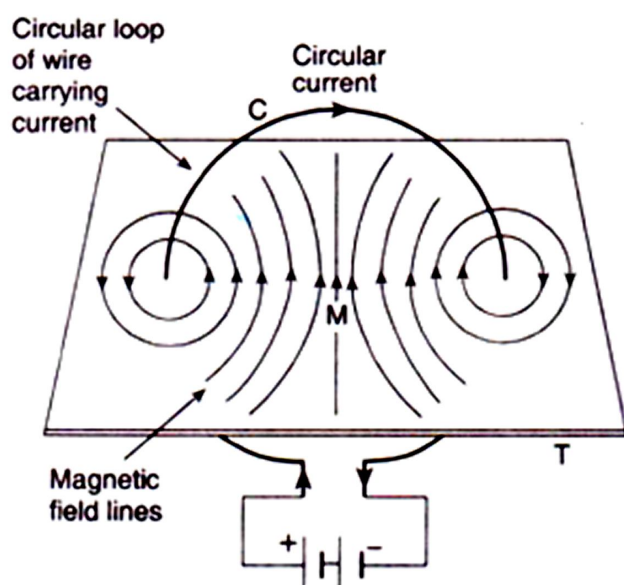

Magnetic lines of force due to a circular wire carrying current

- iii) Sprinkle iron filings uniformly on the cardboard.
- iv) Allow the current to pass through the coil by inserting plug in the key.
- v) Note the pattern of iron filings that emerges on the cardboard after tapping gently a few times. (Observation).
- vi) Place the compass at any point over the pattern of field. Observe the direction of needle. (Observation 2).

Observations :

- (a) Iron filings are arranged in the form of concentric circles.
- (b) The concentric circles become larger and larger as we move away from the wire.
- (c) At the centre of loop, lines are almost straight and perpendicular to the plane of the loop.

Conclusion :

- i) The concentric circles at every point of a current carrying circular loop represent the magnetic field around it.
- ii) Magnetic field line close to the axis of loop is straight and is perpendicular to the plane of the coil.
- iii) Field lines keep on diverging as we move away from the centre of loop.

LONG ANSWER TYPE QUESTION [5 MARKS]

58. (a) Describe activity with labelled diagram to show that a current carrying conductor experience a force in a magnetic field.

(b) State the rule to determine the direction of force.

Answer.

(a) Without using a magnet, magnetic field can be produced by flowing the current through a straight conductor or a solenoid.

Aim : To show that magnetic field exerts a force on a current carrying conductor.

Apparatus required : Aluminium rod, stand, strong horse shoe magnet, cell, key and connecting wires.

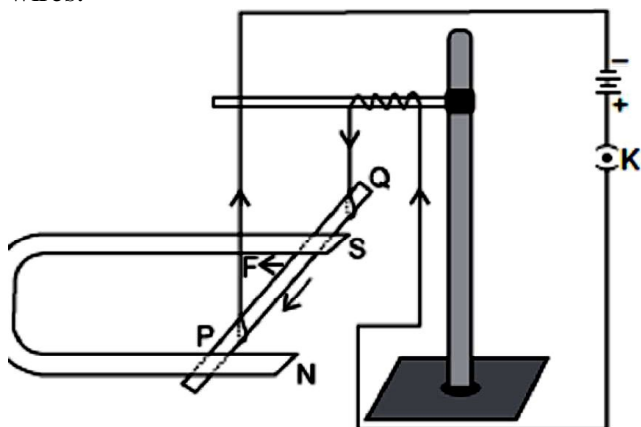

A current carrying rod, PQ is experiencing force F

Procedure :

- i) Hang the aluminium rod with the help of clamp stand such that it passes between the North and South pole of the magnet with the magnetic field directed upwards and the rod being horizontal and perpendicular to the field.
- ii) Connect the aluminium rod in series with a battery, a key as shown in figure.
- iii) Plug the key, the current flows through the rod from Q to P and observe the direction of motion of the rod.
- iv) Reverse the direction of current by reversing the battery connection. Again observe the direction of displacement of aluminium rod.
- v) Restore the original direction of current and change the direction of field vertically downwards by interchanging the two poles of the magnet. Observe the deflection of rod again.
- vi) Place the wire parallel to magnetic field and allow the current to pass through it. Check the deflection of rod again.

Observation :

- i) On plugging the key in step 3, the aluminium rod moves towards left.
- ii) In step 4, rod displaces towards right.
- iii) In step 5, rod moves towards right again.
- iv) In step 6, rod does not move in any direction.

Conclusion :

- i) Magnetic field exerts a force on a current carrying conductor.

- ii) The force exerted on the current carrying conductor depends upon the direction of current and direction of magnetic field acting on it.
- iii) Displacement of the rod or the magnetic force on it is largest when the direction of current is at right angle to the direction of magnetic field.
- iv) When current carrying conductor is placed parallel to the magnetic field, it experiences no force.

(b) Direction of force experienced by a current carrying straight conductor placed in a magnetic field which is perpendicular to it is given by Fleming's left hand rule.

Stretch the thumb, forefinger and middle finger of left hand in such a way that they are mutually perpendicular to each other. If the forefinger points in the direction of magnetic field and the middle finger in the direction of current, then the thumb will point in the direction of motion or the force acting on the conductor.

59. (a) Describe an activity to demonstrate the pattern of magnetic field lines around a straight conductor carrying current.

(b) State the rule to find the direction of magnetic field associated with a current carrying conductor.

(c) What is the shape of a current carrying conductor whose magnetic field pattern resembles that of a bar-magnet ?

Answer.

(a) **Aim :** To study the magnetic field due to a straight current carrying conductor.

Apparatus Required : A thick conducting wire, battery, rheostat, magnetic needle, ammeter (0-5 A), key, a cardboard, a stand to hold the wire, iron filings and sprinkler of iron filings.

Procedure :

- i) Attach the thick wire through a hole at the middle of the cardboard and clamp it in a stand.
- ii) Attach the ends of the wire through a key, variable resistor and an ammeter on either side of a battery and hold it vertically and perpendicularly to the board.
- iii) Spread the iron filings uniformly on the cardboard and place the magnetic needle on the board.
- iv) Close the key and tap the cardboard slightly and observe the orientation of iron filings.

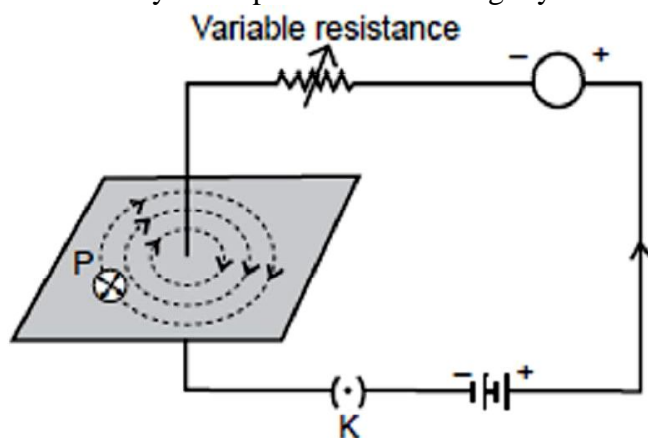

Magnetic field around a straight conducting wire.

Concentric circles indicate the field lines

Observation :

Just on closing the key, the iron filings are aligned in the pattern of concentric circles around the wire.

Conclusion :

- i) Current carrying conductor is a source of magnetic field.
- ii) The magnetic field is in the form of concentric circles whose centre lies on the wire.
 - (b) Right-Hand Thumb Rule. This rule is used to find the direction of magnetic field due to a straight current carrying wire.

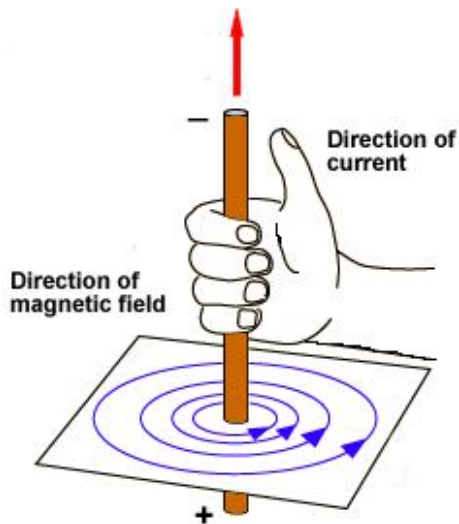

It states that if we hold the current carrying-conductor in the right hand in such a way that the thumb is stretched along the direction of current, then the curly finger around the conductor represent the direction of magnetic field produced by it. This is known as right-hand thumb rule.

Direction of Field Lines due to current carrying straight conductor is as shown in figure.

(c) Solenoid.

60. (a) Explain why there are two separate circuits one for high power rating appliances and other for low power rating appliances.
 (b) A domestic circuit has 5A fuse. How many bulbs of rating 100W, 220V can be safely used in this circuit? Justify your answer.

Answer.

(a) Two separate circuits are formed in the domestic wiring, one for high power rating appliances called power circuit and other for low power rating called lightning circuit.

Power circuit: The circuit which draw heavy current (15 A) from mains and used for high power rating devices such as microwave, oven, air conditioners, geysers, washing machine, etc., is known as power circuit. Lightning circuit: The circuit which draw small amount of current from the mains and used for low power rating devices such as bulb, tube light, fans, T.V., Computer, etc. having a current rating of 5 A is known as lightning circuit.

(b) In India, the correct voltage is 220 V.

Electric current flowing in the circuit is given by

$$I = \frac{P}{V}$$

Hence, $I = 5 \text{ A}$, $V = 220 \text{ V}$ and $P = n \times 100$

Where, $n =$ number of bulbs

$$\therefore 5 = \frac{n \times 100}{220}$$

$$\therefore n = \frac{5 \times 220}{100} = \frac{1100}{100} = 11$$

So, 11 bulbs of 100 W can be used in the house at correct voltage.

61. (i) Design an activity with the help of two nails, very thin aluminium strip, a 12 V Battery and a key to illustrates.
 (ii) Cable of a microwave oven has three wires inside it which have insulation of different colours black, green and red. Mention the significance of the three colours and potential difference between red and black one.

Answer.

(a) **Aim:** How electric fuse works?

Apparatus required : Two nails, card board, very thin aluminium strip, a 12 V battery, key and connecting wires.

Procedure:

Insert the two nails vertically on the card board.

Take very thin aluminium strip and tie it between the nails.

Make a circuit as shown in figure with 12 V battery and key with the help of connecting wires.

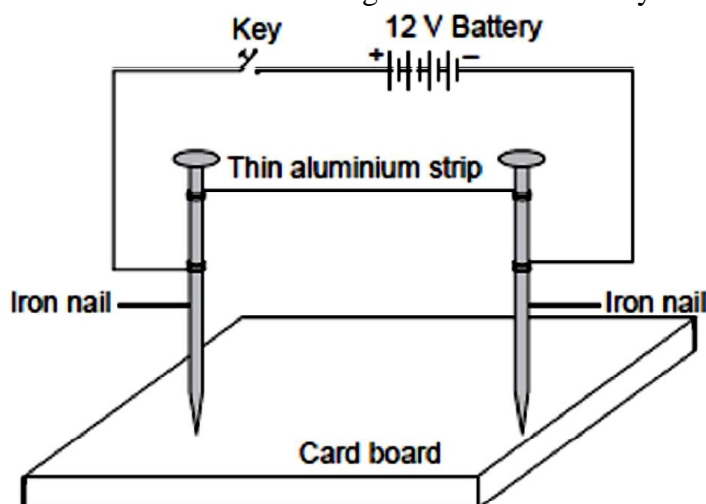

If there are any fans running in the room, switch them off.

Now switch on the current in the circuit by pressing the key or by moving the switch of the 'ON' position.

Now pass the current through the circuit for some time. Observe the strand of aluminium strip between the two nails carefully.

Observation: The strand of aluminum strip melt and break quickly on passing the large electric current through it.

Conclusion: When current flows through the circuit, exceed the rating of aluminium strip, i.e. safe limit, its temperature increases. This make it overheated. As a result, aluminium strip melts and breaks the circuit. Hence, very thin aluminium strip between the two nails acts as a fuse wire. This activity shows that how fuse works.

(b) Significance of insulation colour:

Red colour insulation wire – Live wire

Black colour insulation wire – Neutral wire

Green colour insulation wire – Earth wire

Live wire is at higher potential of 220 V while neutral wire is at zero potential. So, potential difference between red and black insulation wire is 220 V.

62. Two coils C_1 and C_2 are wrapped around a non conducting cylinder. Coil C_1 is connected to a battery and key and C_2 with galvanometer G . On pressing the key (K), current starts flowing in the coil C_1 . State your observation in the galvanometer:

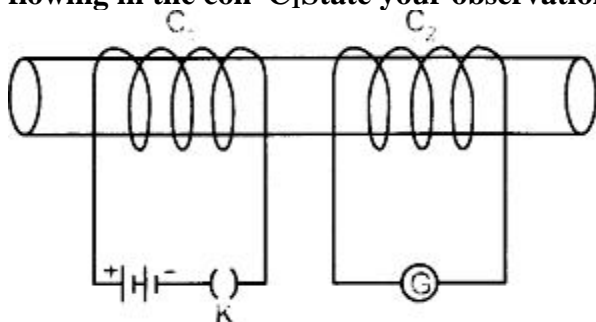

(i) When key K is pressed on

(ii) When current in the coil C_1 is switched off.

(iii) When the current is passed continuously through coil C_1

(iv) Name and state the phenomenon responsible for the above observation. Write the name of the rule that is used to determine the direction of current produced in the phenomena.

Answer.

(i) When key is pressed on, the galvanometer needle deflects momentarily in one direction.

(ii) When the current in the coil C_1 is switched off, the galvanometer needle deflects again

momentarily but in opposite direction to that in the previous case.

(iii) When current is passed continuously through coil C_1 , no deflection is observed in the galvanometer.

(iv) The phenomenon responsible for the above observations is electromagnetic induction. Electromagnetic Induction: The process, by which a changing magnetic field in a conductor induces a current in another conductor placed nearby, is called electromagnetic induction.

• Fleming's right hand rule is used to determine the direction of current produced in the phenomena of electroynagnetic induction.

63. **Two coils of insulated copper wire are wound over a non -conducting cylinder as shown.**

Coil I has larger number of turns.

(i) Write your observations when,

(a) key K is closed,

(b) key K is opened.

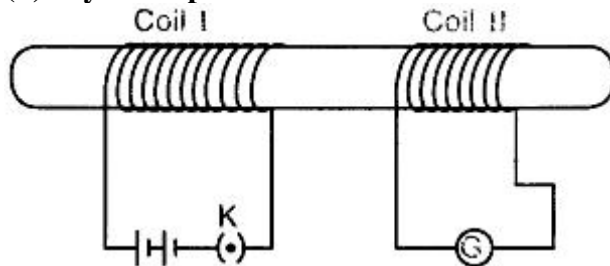

(ii) When the current is passed continuously through coil I.

Give reason for your observations.

(iii) Name and state the phenomenon responsible for the above observation.

(iv) Write the name of the rule that is used to determine the direction of current produced in the phenomenon.

(v) Name the two coils used in this experiment.

Answer.

(i) (a) When key is closed, the galvanometer needle deflects momentarily in one direction. ,

Reason: When key is closed, magnetic field lines around coil 2 increases momentarily. This causes an induced current to flow through it and hence deflection occurs in one direction.

(b) When key is opened, the galvanometer needle deflects again momentarily but in opposite direction.

Reason: When key is open, magnetic field lines around coil 2 decreases momentarily. This causes an induced current to flow in opposite direction. Hence, deflection occurs in opposite direction.

(ii) When current is passed continuously through coil I, no deflection is observed in the galvanometer.

Reason: There will be no change in magnetic field lines passing through the coil 2. Hence, no induced current will be set up in coil 2.

(iii) The phenomenon observed in above cases is electromagnetic induction. It is a process by which a changing magnetic field in a conductor induces a current in another conductor placed nearby.

(iv) Fleming's right hand rule

(v) Coil I – Primary coil Coil II – Secondary coil

64. **(a) Mention the effect of electric current on which the working of an electrical fuse is based.**

(b) Draw a schematic labelled diagram of a domestic circuit which has a provision of a main fuse, meter, one light bulb and a socket.

(c) Explain the term overloading of an electric circuit.

Answer.

(a) Heating effect of electric current.

(b) Domestic circuit wiring consists of a main fuse, meter, one light bulb and a socket.

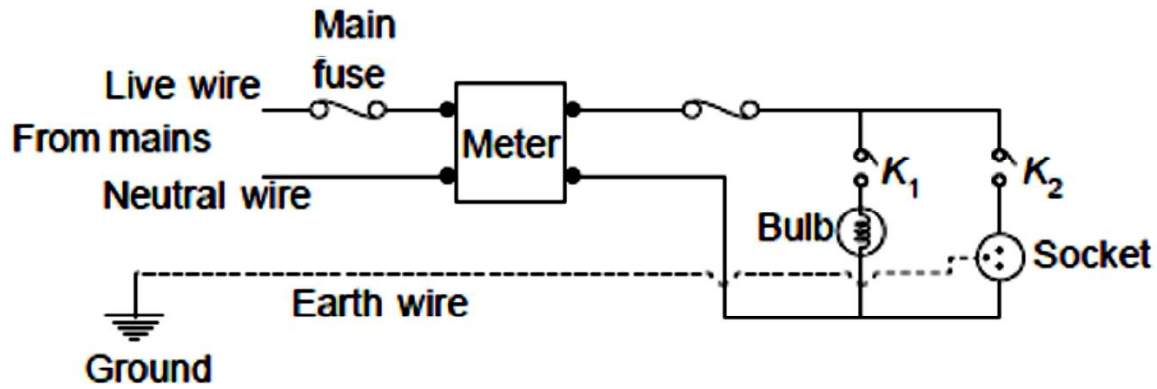

(c) The flow of large amount of current through the circuit beyond its bearing capacity due to use of many high power rating devices at the same time is called overloading.

65. Observe the figure given below and answer the following questions:

(a) Write the special name given to the coil AB which has many circular turns of insulated copper wire.

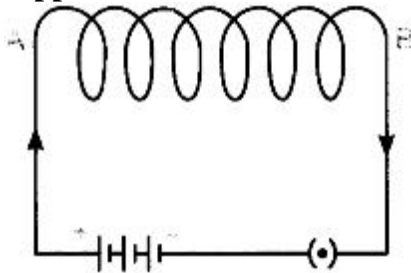

(b) State the nature of magnetic field inside AB when a current is passed through it.

(c) Redraw the diagram and sketch the pattern of magnetic field lines through and around AB.

(d) List two factors on which the strength of the magnetic field produced by AB depends.

(e) What is the effect of placing an iron core in the coil AB?

Answer.

(a) Solenoid.

(b) Uniform magnetic field.

(c)

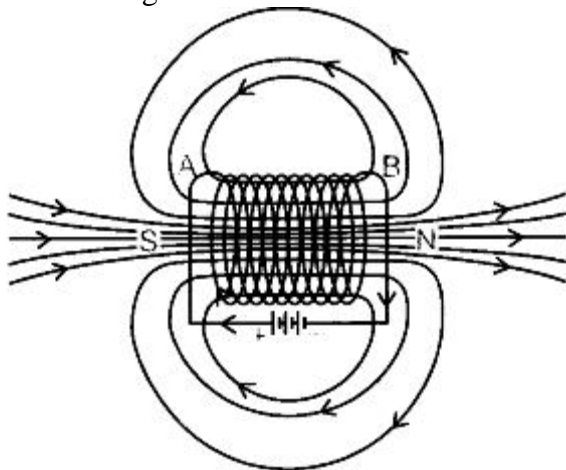

(d) (i) Magnitude of current flowing through it.

(ii) Number of turns of a circular coil.

(e) It becomes an electromagnet.

66. (a) Describe an activity to demonstrate the pattern of magnetic field lines around a straight conductor carrying current.

(b) State the rule to find the direction of magnetic field associated with a current-carrying conductor.

(c) What is the shape of a current-carrying conductor whose magnetic field pattern resembles that of a bar-magnet?

Answer.

(a) **Aim:** To study the magnetic field due to a straight current-carrying conductor.

Apparatus Required: A thick conducting wire, battery, rheostat, magnetic needle, ammeter (0-5 A), key, a cardboard, a stand to hold the wire, iron filings and sprinkler of iron filings.

Procedure:

Attach the thick wire through a hole at the middle of the cardboard and clamp it in a stand.

Attach the ends of the wire through a key, variable resistor and an ammeter. on either side of a battery and hold it vertically and perpendicularly to the board.

Spread the iron filings uniformly on the cardboard and place the magnetic needle on the board.

Close the key and tap the cardboard slightly and observe the orientation of iron filings.

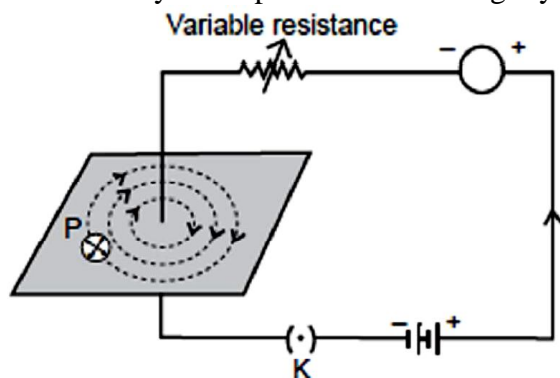

Magnetic field around a straight conducting wire.

Concentric circles indicate the field lines

Observation: Just on closing the key, the iron filings are aligned in the pattern of concentric circles around the wire.

Conclusion:

A current-carrying conductor is a source of magnetic field.

The magnetic field is in the form of concentric circles whose centre lies on the wire.

(b) **Right – Hand thumb Rule:** Hold the current-Carrying wire in your right hand, such that the thumb indicates the direction of current, then the folded fingers will indicate the direction of magnetic field (lines) surrounding the wire.

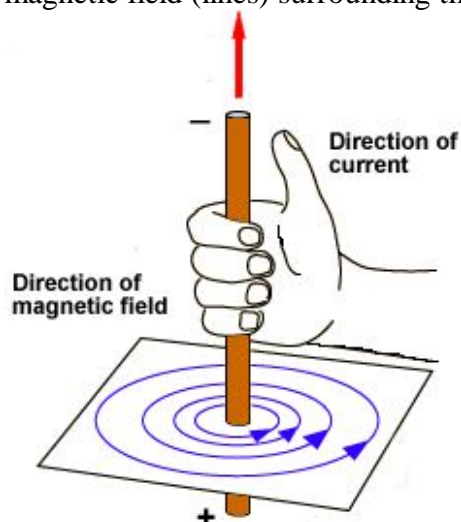

(c) Solenoid.

67. (a) **Draw a diagram to represent a uniform magnetic field in a given region.**

(b) **List two properties of magnetic field lines.**

Answer.

(a) Equidistant parallel line indicates a uniform magnetic field in a given region.

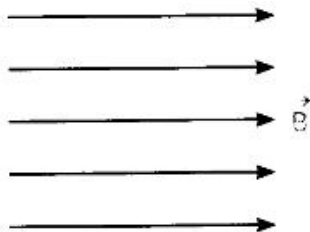

(b) Properties of magnetic field lines are:

The magnetic field lines of a magnet form continuous closed loops, i.e. outside the magnet, they emerge from north pole and merge at the south pole and inside the magnet, the direction of field lines is from its south pole to its north pole.

The degree of closeness of field lines indicates the strength of magnetic field.

Field lines never cross each other.

68. (i) **With the help of an activity, explain the method of inducing electric current in a coil with a moving magnet. State the rule used to find the direction of electric current thus generated in the coil.**

(ii) **Two circular coils P and Q are kept close to each other, of which coil P carries a current. What will you observe in Q**

(a) **if current in the coil P is changed?**

(b) **if both the coils are moved in the same direction with the same speed? Give reason.**

Answer.

(i) Take a coil AB of wire having a large number of turns.

Connect the ends of coil to a sensitive galvanometer as shown in figure.

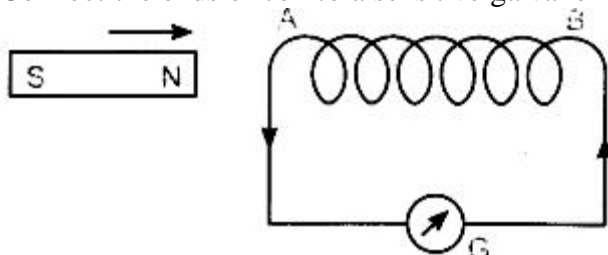

Take a strong bar magnet and move its north pole towards the end 'A' of coil. The deflection in the needle of galvanometer indicates that the induced current flows in the circuit in anticlockwise direction. The end A of the coil behaves as a north pole.

When north pole of the magnet moves away from the coil, the deflection in the galvanometer occurs but in opposite direction.

Similar observations can be made when south pole of the magnet is moved towards the coil or away from it.

When magnet is kept at rest with respect to the coil, the deflection in the needle of galvanometer drops to zero.

Thus, the motion of a magnet, with respect to the coil, produces an induced potential difference which sets up an induced electric current in the circuit.

The direction of electric current thus generated in the coil can be found by using the Fleming's right-hand rule.

(ii) **Fleming's right-hand rule:** Stretch the thumb, forefinger and middle finger of right hand in such a way that they are mutually perpendicular to each other. If the forefinger indicates the direction of magnetic field and thumb shows the direction of motion of the conductor, then the middle finger will indicate the direction of induced current.

(a) If current in the coil P is changed, the magnetic field lines of forces linked with coil Q also change. So, induced potential difference is set up in the coil Q. This results in induced electric current in coil Q which opposes the change in current in coil P.

(b) If both the coils are moved in the same direction with the same speed, there will be no relative motion between them and hence, there will be no change in magnetic field lines of force associated with the secondary coil. Hence, no current will be induced in the coil.

69. Consider a circular loop of wire lying in the plane of the paper. Let the current pass through the loop clockwise. With the help of a diagram, explain how the direction of the magnetic field can be determined inside and outside the loop. Name the law used to find the direction of magnetic field.

Answer. Consider a circular loop of wire of radius r with centre O lying in the plane of the paper. Let the current i pass through the loop clockwise. According to right hand thumb rule, direction of magnetic field due to any portion of small current carrying length of the coil is:
 Direction of magnetic field inside the loop — Perpendicular to the plane of paper inwards.
 Direction of magnetic field outside the loop — Perpendicular to the plane of paper outwards.

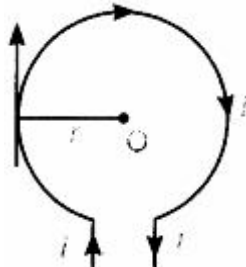

So, the direction of magnetic field can be considered as the direction of total magnetic field due to circular coil as current through all the elements will contribute to the magnetic field in the same direction.

70. Why is pure iron not used for making permanent magnets? Name one material used for making permanent magnets. Describe how permanent magnets are made electrically. State two examples of electrical instruments made by using permanent magnets.

Answer.

- Pure iron cannot retain its magnetism for long time. Hence it cannot be used for making permanent magnet.
- Cobalt-steel or some alloys of iron such as ALNICO are used for making permanent magnet.
- Formation of permanent magnet electrically A current carrying solenoid is used to magnetise steel rod. Steel rod is kept inside the solenoid. A strong uniform magnetic field produced by the current carrying solenoid magnetise it. The magnet so formed retains the magnetism even after switching off the current in solenoid.
- Permanent magnets are used in (i) Galvanometer and (ii) loudspeaker

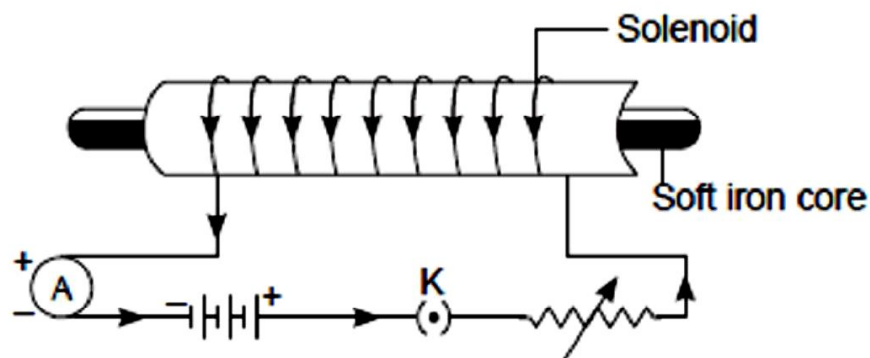

ELECTRICITY

1. Name a device that helps to maintain a potential difference across a conductor.

Answer. Cell or battery

2. Define 1 volt. Express it in terms of SI unit of work and charge calculate the amount of energy consumed in carrying a charge of 1 coulomb through a battery of 3 V.

Answer. When 1 joule of work is done in carrying 1 coulomb of charge, from infinity to a point in the electric field, then potential at that point is called 1 volt. Potential difference between two points is

$$V = \frac{W}{Q}$$

or

$$W = Q \times V \\ = 1 \times 3 = 3 \text{ J}$$

3. Write S.I. unit of resistivity.

Answer. Ohm-metre (Ωm).

4. How is an ammeter connected in a circuit to measure current flowing through it?

Answer. In series

5. What happens to resistance of a conductor when its area of cross-section is increased?

Answer.

Resistance decreases as $R \propto \frac{1}{A}$.

6. Name the physical quantity which is (i) same (ii) different in all the bulbs when three bulbs of:

(a) same wattage are connected in series.

(b) same wattage are connected in parallel.

(c) different wattage are connected in series.

(d) different wattage are connected in parallel.

Answer. (a) For identical bulbs in series- same current, same potential difference.

(b) For identical bulbs in parallel- same potential difference, different current.

(c) For unidentical bulbs in series- same current, different potential difference.

(d) For unidentical bulbs in parallel- different current, same potential difference.

7. A given length of a wire is doubled on itself and this process is repeated once again. By what factor does the resistance of the wire change?

Answer. Am. Length becomes one-fourth of the original length and area of cross-section becomes four times that of original.

i.e. $l_2 = \frac{1}{4}l_1$ and $A_2 = 4A_1$

$$\therefore \frac{R_2}{R_1} = \frac{l_2}{l_1} \times \frac{A_1}{A_2} = \frac{1}{4} \times \frac{1}{4} = \frac{1}{16}$$

$$\Rightarrow R_2 = \frac{1}{16}R_1$$

So, new resistance is (1/16)th of original resistance.

8. What is an electric circuit? Distinguish between an open and a closed circuit.

Answer. An arrangement for maintaining the continuous flow of electric current by the electrical energy source through the various electrical components connected with each other by conducting wires is termed as electric circuit.

An open circuit does not carry any current, while a closed circuit carries current.

9. (a) Define the term 'volt'.

(b) State the relation between work, charge and potential difference for an electric circuit.

Calculate the potential difference between the two terminals of a battery if 100 J of work is required to transfer 20 C of charge from one terminal of the battery to the other.

Answer.

(a) When 1 joule of work is done in carrying 1 coulomb of charge, from infinity to a point in the electric field, then potential at that point is called 1 volt.

(b) Potential difference, $V = \text{Work done on unit charge} = W/q$

Work is 100 J, $q=20\text{C}$

Potential difference, $V=W/q=100/20=5\text{V}$

10. A 9Ω resistance is cut into three equal parts and connected in parallel. Find the equivalent resistance of the combination.

Answer.

$$\text{Resistance of each part} = \frac{R}{3} = \frac{9}{3} = 3 \Omega$$

$$\therefore R_1 = R_2 = R_3 = 3 \Omega$$

In parallel combination,

$$\begin{aligned} \frac{1}{R_p} &= \frac{1}{R_1} + \frac{1}{R_2} + \frac{1}{R_3} \\ &= \frac{1}{3} + \frac{1}{3} + \frac{1}{3} = \frac{3}{3} = 1 \end{aligned}$$

$$\therefore R_p = 1 \Omega$$

11. (a) Define the term 'coulomb'.

(b) State the relationship between the electric current, the charge moving through a conductor and the time of flow.

Calculate the charge passing through an electric bulb in 20 minutes if the value of current is 200 mA.

Answer.

$$I = \frac{q}{t}$$

$$t = 20 \times 60 = 1200 \text{ seconds,}$$

$$I = 200 \text{ mA} = 200 \times 10^{-3} \text{ A}$$

$$\text{Charge passing} = q = It = 200 \times 10^{-3} \times 1200 = 240 \text{ C}$$

(a) When 1 A current flows across the wire in 1 second, the charge transfer across its ends is said to be 1 coulomb.

(b) The relationship between the electric current I, the charge q and time t is

12. (a) How is the direction of electric current related to the direction of flow of electrons in a wire?

(b) Calculate the current in a circuit if 500 C of charge passes through it in 10 minutes.

Answer.

(a) Conventional direction of electric current is opposite to the direction of flow of electrons in a wire.

(b) $q = 500 \text{ C}$, $t = 10 \times 60 = 600 \text{ s}$

$$I = 500/600 = 5/6 \text{ A}$$

13. An electric iron has a rating of 750 W, 220 V. Calculate the (i) current flowing through it, and (ii) its resistance when in use.

Answer. Given: $P = 750 \text{ W}$, $V = 220 \text{ V}$

(i) $P = VI$

$$750 = 220 \times I \Rightarrow I = \frac{750}{220} = 3.40 \text{ A}$$

$$(ii) \quad P = \frac{V^2}{R} \Rightarrow R = \frac{V^2}{P} = \frac{220^2}{750} \Rightarrow R = 64.53 \Omega$$

14. Study the following electric circuit and find (i) the current flowing in the circuit and (ii) the potential difference across 10Ω resistor.

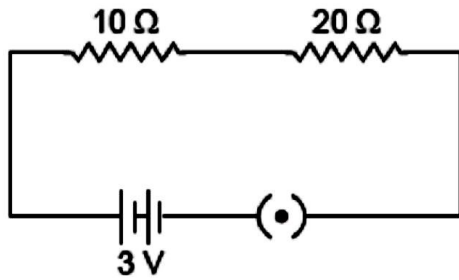

Answer.

10 Ω and 20 Ω are connected in series, their equivalent resistance is

$$R_s = R_1 + R_2 \\ = 10 + 20 = 30 \Omega$$

(i) Current flowing in the circuit

$$I = \frac{V}{R_s} = \frac{3}{30} \\ = \frac{1}{10} = 0.1 \text{ A}$$

(ii) Potential difference across 10 Ω resistor

$$V = IR \\ = \frac{1}{10} \times 10 = 1 \text{ volt.}$$

15. What is meant by electric current? Name and define its SI unit. In a conductor electrons are flowing from B to A. What is the direction of conventional current? Give justification for your answer. A steady current of 1 ampere flows through a conductor. Calculate the number of electrons that flows through any section of the conductor in 1 second. (Charge on electron 1.6×10^{-19} coulomb).

Answer.

- Electric Current: The amount of charge 'Q' flowing through a particular area of cross section in unit time 't' is called electric current, i.e.
- Electric current, $I = Q/t$
- SI unit of electric current is ampere.
- One ampere of current is that current which flow when one coulomb of electric charge flowing through a particular area of cross-section of the conductor in one second, i.e. $1\text{A} = 1 \text{Cs}^{-1}$.
- The direction of conventional current is A to B, i.e. opposite to the direction of flow of electrons. In a metal, flow of electrons carrying negative charge constitutes the current. Direction of flow of electrons gives the direction of electronic current by convention, the direction of flow of positive charge is taken as the direction of conventional current.
Charge = $q = ne$

$$\text{For } q = 1 \text{ coulomb, } n = \frac{1 \text{ C}}{1.6 \times 10^{-19} \text{ C}} = \frac{10^{19}}{1.6} = 6.25 \times 10^{18} \text{ electrons}$$

16. What is meant by electrical resistivity of a material? Derive its S.I. unit.

Answer. Mathematically, resistivity of the conducting material is given by

$$\rho = R \times A/J$$

If $l = 1 \text{ m}$, $A = 1 \text{ m}^2$, then $\rho = R$

Hence, the resistivity of the material is defined as the resistance offered by a metallic wire having a unit length and a unit area of cross-section. Since unit length and unit area of cross-section forms a cube, the specific resistance or resistivity can also be defined as the resistance offered by a cube of a material of side 1 m when current flows perpendicularly through the opposite faces. In

SI system, its units is

$$\text{Unit of } \rho = \frac{\text{Unit of } R \times \text{Unit of area of cross-section}}{\text{Unit of length of conductor}}$$

$$= \frac{\Omega \times \text{m}^2}{\text{m}} = \Omega\text{m}$$

17. (a) Write two points of difference between electric energy and electric power. (6) Out of 60 W and 40 W lamps, which one has higher electrical resistance when in use.

(c) What is the commercial unit of electric energy? Convert it into joules.

Answer. (a) Difference between electric energy and electric power:

Electrical energy	Electric power
(i) The work done or energy supplied by the source in maintaining the flow of electric current is called electrical energy. It appears in the form of heat given by $H = VI t = \frac{V^2 t}{R} = I^2 R T$	(i) The time rate at which electric energy is consumed or dissipated by an electrical device is called electric power and is given by $P = VI = \frac{V^2}{R} = I^2 R$
(ii) It is equal to the product of power and time i.e. $E = P \times t$	(ii) It is equal to the rate of doing work by an energy source i.e. $P = \frac{W}{t}$
(iii) Its SI unit is joule (J) $1 \text{ J} = 1 \text{ W} \times 1 \text{ s}$	(iii) Its SI unit is watt (W) $1 \text{ W} = 1 \text{ J s}^{-1}$

i.e. less the power of electrical device, higher is its electrical resistance.

(c) Kilowatt hour – Commercial unit of electrical energy

$$1 \text{ kWh} = 1000 \text{ Wh} = 1000 \text{ J/S} \times 3600 \text{ sec}$$

$$= 3600000 \text{ J} = 3.6 \times 10^6 \text{ J}$$

18. Draw a labelled circuit diagram showing three resistors R_1 , R_2 and R_3 connected in series with a battery (E), a rheostat (Rh), a plug key (K) and an ammeter (A) using standard circuit symbol. Use this circuit to show that the same current flows through every part of the circuit. List two precautions you would observe while performing the experiment.

Answer.

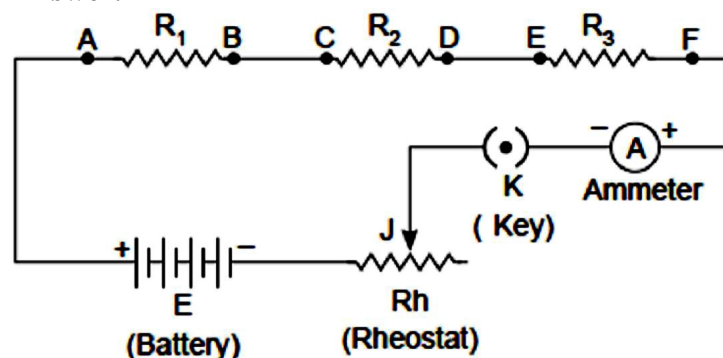

Aim: Same current flows through every part of the above circuit.

Procedure:

Connect ammeters, 'A₁' between B and C, and 'A₂' between D and E.

Adjust the sliding contact of the rheostat initially for a small current.

Note all the ammeter readings. These reading give us current flowing through the resistors R_1 , R_2 and R_3

The current in the circuit is now increased by changing the position of sliding contact J' of the rheostat.

Note all the ammeter readings each time.

Conclusion: Same reading of all the ammeter in each observation concluded that same current flows through every part of the circuit.

Precautions:

All the connection should be tight and properly connected as per circuit diagram.

The positive terminal of the ammeter and voltmeter must be connected to the positive terminal of the battery or battery eliminator.

19. **State Ohm's law. Write the necessary conditions for its validity. How is this law verified experimentally? What will be the nature of graph between potential difference and current for a conductor? Name the physical quantity that can be obtained from this graph.**

Answer. Ohm's law : When the physical conditions such as temperature etc. remain same, the current flowing through the conductor is directly proportional to the potential difference applied across the ends of the conductor, i.e.,

$$I \propto V \text{ or } V \propto I$$

$$\Rightarrow \frac{V}{I} = \text{constant}$$

$$\Rightarrow V = IR$$

where R is constant of proportionality and is called resistance of the wire.

Necessary condition for validity of Ohm's law is that physical condition such as temperature of the conductor remains same.

Procedure:

Experiment to verify ohm's law

Procedure : 1. Connect the various components as.

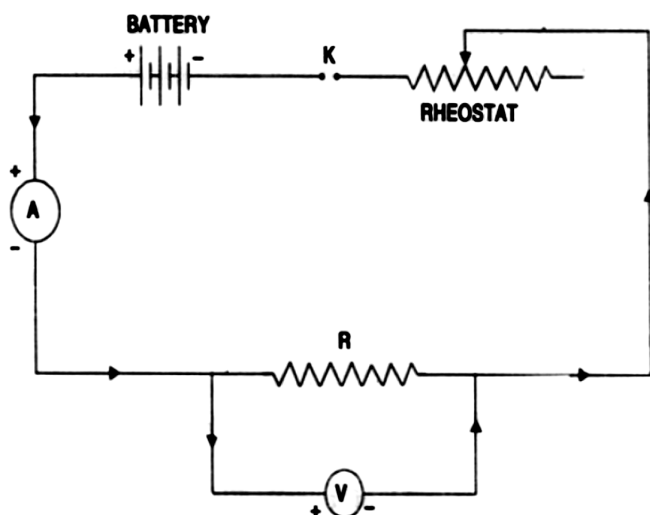

2. Close the key, so that current begins to flow in the circuit.
3. Note down the potential difference (V) across the conductor PQ of resistance R shown by the voltmeter and the corresponding current (I) shown by the ammeter.
4. Now move the knob of rheostat so that the current in the circuit increases.
5. Again note down the potential difference (V) across the conductor R in the voltmeter and current in the circuit shown by ammeter.
6. Repeat the experiment five times by increasing the current in the circuit by moving the knob of the rheostat in steps.

S. No.	Potential Difference (V)	Current (I)	V/ I
1			
2			
3			
4			

The value of $V/I = R$ (constant)

Plot a graph between V and I by taking V along X- axis along. We get a straight line passing through origin.

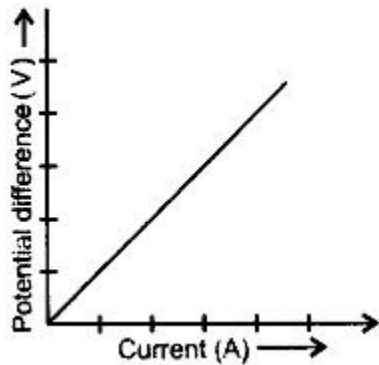

Conclusion : From the graph between V and I, we conclude that $I \propto V$, which is Ohm's law. Hence Ohm's law is verified experimentally.

Ohm's law does not hold under all conditions. Ohm's law does not hold for non-ohmic material such as electrolyte.

20. (a) Define electric power. Express it in terms of potential difference V and resistance R.
 (b) An electrical fuse is rated at 2 A. What is meant by this statement?
 (c) An electric iron of 1 kW is operated at 220 V. Find which of the following fuses that respectively rated at 1 A, 3 A and 5 A can be used in it.

Answer.

(a) Electric power: It is the rate of doing work by an energy source or the rate at which the electrical energy is dissipated or consumed per unit time in the electric circuit is called electric power.

$$\begin{aligned} \text{So, Power } P &= \frac{\text{Work done } (w)}{\text{Time } (t)} \\ &= \frac{\text{Electrical energy dissipated}}{\text{Time } (t)} \\ &= VI = \frac{V^2}{R} \end{aligned}$$

(b) It means, the maximum current will flow through it is only 2 A. Fuse wire will melt if the current exceeds 2 A value through it.

(c) Given: $P = 1 \text{ kW} = 1000 \text{ W}$, $V = 220 \text{ V}$

$$\text{Current drawn, } I = \frac{P}{V} = \frac{1000}{220} = \frac{50}{11} = 4.54 \text{ A}$$

To run electric iron of 1 kW, rated fuse of 5 A should be used.

21. Write relation between heat energy produced in a conductor when a potential difference V is applied across its terminals and a current I flows through for 't'

Answer. Heat produced, $H = VIt$

22. State difference between the wire used in the element of an electric heater and in a fuse wire.

Answer. The wire used in the element of electric heater has a high resistivity and have a high melting point, i.e. even at a high temperature element do not burn while fuse wire have a low melting point and high resistivity.

23. Find the current flowing through the following electric circuit.

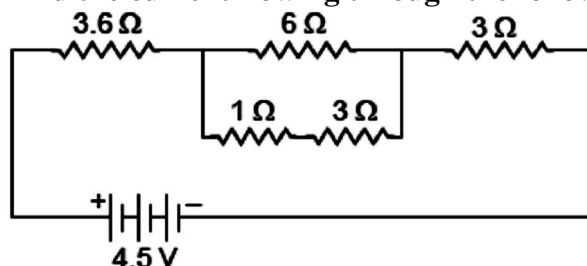

Answer.

Series combination of 1 Ω and 3 Ω resistance is in parallel combination with 6 Ω. Their equivalent resistance is

$$\frac{1}{R_p} = \frac{1}{6} + \frac{1}{3+1} = \frac{1}{6} + \frac{1}{4} = \frac{2+3}{12}$$

$$\therefore R_p = \frac{12}{5} = 2.4 \Omega$$

Now, 3.6 Ω, 2.4 Ω and 3 Ω are in series, their equivalent resistance be

$$\begin{aligned} R_s &= R_1 + R_2 + R_3 \\ &= 3.6 + 2.4 + 3 = 9 \Omega \end{aligned}$$

Hence, the current flowing through the circuit is

$$I = \frac{V}{R} = \frac{4.5}{9} = \frac{45}{90} = \frac{1}{2} = 0.5 \text{ A.}$$

24. An electric bulb of resistance 200Ω draws a current of 1 Ampere. Calculate the power of the bulb the potential difference at its ends and the energy in kWh consumed burning it for 5h.

Answer. Power of the bulb,

Power of the bulb,

$$P = I^2 R = (1)^2 \times 200$$

$$\Rightarrow P = 200 \text{ W}$$

Energy consumed by bulb in 5h in burning = Power × Time

$$= 200 \times 5$$

$$= 1000 \text{ Wh} = 1 \text{ kWh}$$

25. Draw a schematic diagrams of an electric circuit comprising of 3 cells and an electric bulb, ammeter, plug-key in the ON mode and another with same components but with two bulbs in parallel and a voltmeter across the combination.

Answer.

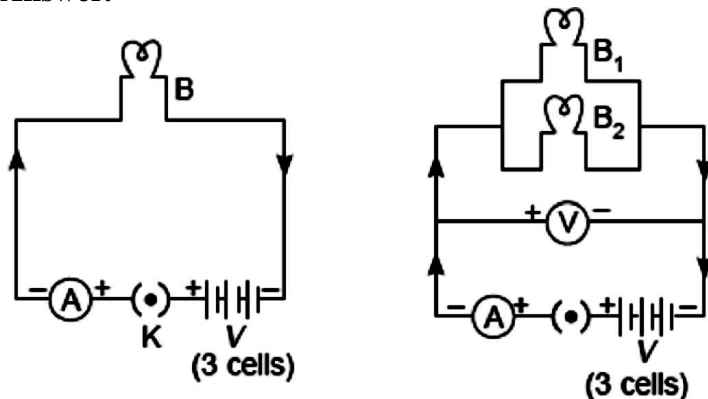

26. Explain the role of fuse in series with any electrical appliance in an electric circuit. Why should a fuse with defined rating for an electric circuit not be replaced by one with a larger rating?

Answer. Fuse wire is a safety device connected in series with the live wire of circuit. It has high resistivity and low melting point. It melts when a sudden surge of large current passes through it and disconnects the entire circuit from the electrical supply. But, in case if we use a larger rating instead of a defined rating, then it will not protect the circuit as high current will easily pass through it and it will not melt.

27. An electric bulb is rated at 60 W, 240 V. Calculate its resistance. If the voltage drops to 192 V, calculate the power consumed and the current drawn by the bulb. (Assume that the resistance of the bulb remain unchanged.)

Answer.

Given: $P_1 = 60 \text{ W}$, $V_1 = 240 \text{ V}$, $R = ?$, $P_2 = ?$, $V_2 = 192 \text{ V}$, $I_1 = ?$

Using,
$$P_1 = \frac{V_1^2}{R}$$

We get
$$R = \frac{V_1^2}{P_1} = \frac{240^2}{60} = 960 \Omega$$

Again
$$P_2 = \frac{V_2^2}{R} = \frac{192 \times 192}{960} = 38.4 \text{ W}$$

Current drawn by bulb at 192 V is

$$I = \frac{V}{R} = \frac{192}{960} = 0.2 \text{ A}$$

Current drawn by bulb at 192 V is

28. The charge possessed by an electron is 1.6×10^{-19} coulombs. Find the number of electrons that will flow per second to constitute a current of 1 ampere.

Answer.

Given: $q = 1.6 \times 10^{-19} \text{ C}$, $I = 1 \text{ A}$, $n = ?$, $t = 1 \text{ s}$

We know, $q = It$ and $q = ne$

$$\therefore ne = It$$

$$\Rightarrow n = \frac{It}{e} = \frac{1 \times 1}{1.6 \times 10^{-19}}$$

$$= 6.25 \times 10^{18} \text{ electrons}$$

29. Two devices of rating 44 W, 220 V and 11 W, 220 V are connected in series. The combination is connected across a 440 V mains. The fuse of which of the two devices is likely to burn when the switch is ON? Justify your answer.

Answer.

Using
$$P = \frac{V^2}{R}$$

$$R_1 = \frac{V^2}{P_1} = \frac{220 \times 220}{44} = 1100 \Omega$$

$$R_2 = \frac{V^2}{P_2} = \frac{220 \times 220}{11} = 4400 \Omega$$

Equivalent resistance in series

$$R_S = R_1 + R_2 = 1100 + 4400 = 5500 \Omega$$

Current,
$$I = \frac{V}{R_S} = \frac{440}{5500} = 0.08 \text{ A}$$

According to Joule's law of heating

$$H_1 = I^2 R_1 t$$
$$= (0.08)^2 \times 1100 \times 1 = 7.04 \text{ J}$$

$$H_2 = I^2 R_2 t$$
$$= (0.08)^2 \times 4400 \times 1 = 28.16 \text{ J}$$

$$\Rightarrow H_2 > H_1$$

30. Consider the circuit shown in the diagram. Find the current in 3Ω resistor.

Answer. 3 Ω and 6 Ω are in parallel.

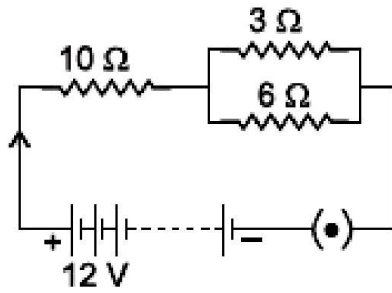

$$\frac{1}{R_p} = \frac{1}{R_1} + \frac{1}{R_2} = \frac{1}{3} + \frac{1}{6} = \frac{1}{2}$$

$$\therefore R_p = 2 \Omega$$

R_p and 10Ω are connected in series. So,

$$R_s = R_p + R_3 = 2 + 10 = 12 \Omega$$

Total current in the circuit,

$$I = \frac{V}{R_s} = \frac{12}{12} = 1 \text{ A}$$

Potential difference across, $R_p = IR_p = 1 \times 2 = 2 \text{ V}$

So, Potential difference across, $3 \Omega = 2 \text{ V}$

Current through 3Ω , $I_1 = \frac{V}{R_1} = \frac{2}{3} = 0.67 \text{ A}$

31. Series arrangements are not used for domestic circuits. List any three reasons.

Answer. Series arrangements are not used for domestic circuit because

The electrical appliances need current of widely different values to operate properly.

In series arrangement, when one component fails, the circuit is broken and none of the components works.

All electrical appliances work at a constant voltage. But in series circuit, the current is constant throughout the electric circuit and potential is different across the different components. So, series arrangement is not suitable for domestic circuits.

32. Explain with the help of a labelled circuit diagram, how will you find the resistance of a combination of three resistors, of resistance R_1 , R_2 and R_3 joined in parallel. Also mention how will you connect the ammeter and the voltmeter in the circuit while measuring the current in the circuit and the potential difference across one of the three resistors of the combination.

Answer. Parallel Combination:

Connect the three given resistor R_1 , R_2 and R_3 in parallel between the point XY with a battery, a plug key and ammeter in series as shown in figure.

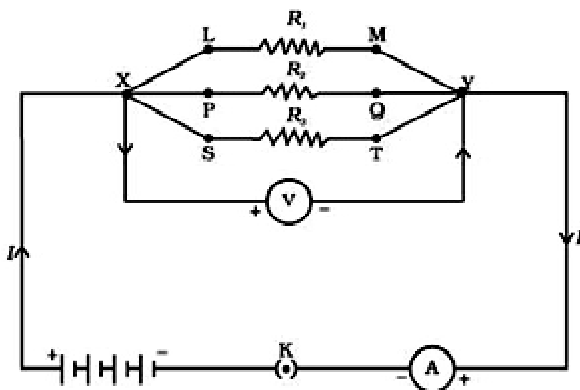

Connect voltmeter in parallel with these resistors between the terminals X and Y.

Close the key and note the ammeter and voltmeter reading. Ammeter shows the total current drawn by the parallel combination of these resistors while voltmeter shows the voltage applied across the combination.

Using Ohm's law, find the equivalent resistance of the combination, i.e. equivalent resistance,

$$R = \frac{\text{Voltmeter reading}}{\text{Ammeter reading}}$$

Thus, in parallel circuit,

$$I = I_1 + I_2 + I_3$$

$$\frac{V}{R_p} = \frac{V}{R_1} + \frac{V}{R_2} + \frac{V}{R_3}$$

$$\Rightarrow \frac{1}{R_p} = \frac{1}{R_1} + \frac{1}{R_2} + \frac{1}{R_3}$$

To find the current flow through any one of the resistor, ammeter will be connected in series with that resistor and to measure the potential difference across that resistor, voltmeter must be connected in parallel with that resistor as shown.

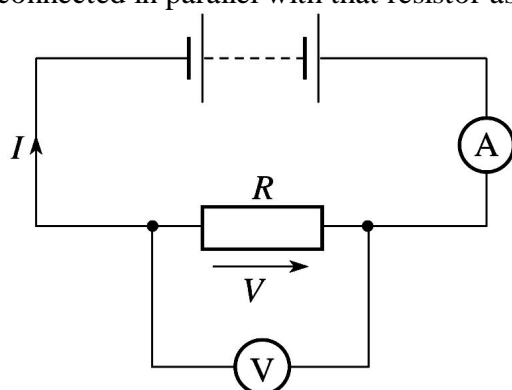

33. Deduce the expression for the equivalent resistance of the parallel combination of three resistors R_1 , R_2 and R_3

Consider the following electric circuit:

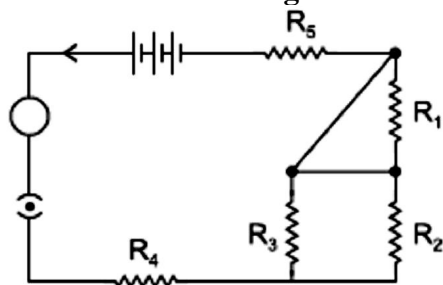

(a) Which two resistors are connected in series?

(b) Which two resistors are connected in parallel?

(c) If every resistor of the circuit is of 2Ω , what current will flow in the circuit?

Answer. Consider the following parallel circuit shown below: Let I_1 , I_2 and I_3 be the current flow through the resistor R_1 , R_2 and R_3 connected in parallel.

Using Ohm's law, current through each resistor is

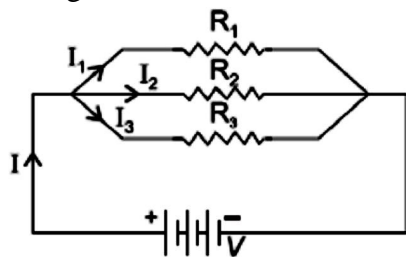

[Parallel circuit]

$$I_1 = \frac{V}{R_1}, I_2 = \frac{V}{R_2} \text{ and } I_3 = \frac{V}{R_3}$$

Let their equivalent resistance be R_p then

$$V = IR_p \Rightarrow I = \frac{V}{R_p}$$

Total current through the circuit is

$$I = I_1 + I_2 + I_3$$

or $\frac{V}{R_p} = \frac{V}{R_1} + \frac{V}{R_2} + \frac{V}{R_3}$

or $\frac{V}{R_p} = V \left(\frac{1}{R_1} + \frac{1}{R_2} + \frac{1}{R_3} \right)$

or $\frac{1}{R_p} = \frac{1}{R_1} + \frac{1}{R_2} + \frac{1}{R_3}$

(a) R_5 and R_4 with Parallel combination of R_2 and R_3 are in series

(b) R_2 and R_3 are in parallel.

(c) R_2 and R_3 in parallel gives $R_p = 1 \Omega$

R_p , R_5 and R_4 are in series. So, $R_{eq} = 5 \Omega$

R_1 is not to be taken as it is shorted.

Current flowing, $I = \frac{V}{R} = \frac{5}{5} = 1A$

34. Draw a schematic diagram of an electric circuit consisting of a battery of five 2 V cells, a 20 Ω resistor, a 30 Ω resistor, a plug key, all connected in series. Calculate the value of current flowing through the 20 Ω resistor and the power consumed by the 30 Ω resistor.

Answer. $R_{eq} = 20 + 30 = 50 \Omega$

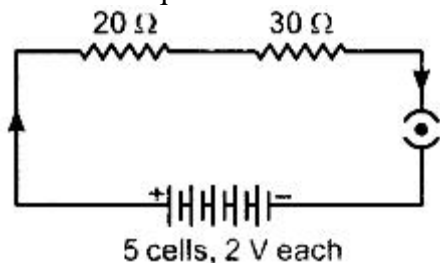

Here, $V = 5 \times 2 V = 10V$, Total Resistance, $R = 20\Omega + 30\Omega = 50\Omega$

Current through both 20 Ω and 30 $\Omega = I = V/R = 10/50 A = 0.2 A$

Power consumed by 30 $\Omega = I^2R = (0.2)^2 \times 30 = 1.2W$

35. Derive the expression for the heat produced due to a current I flowing for a time interval 't' through a resistor 'R' having a potential difference 'V' across its ends. With which name is the relation known? How much heat will an instrument of 12 W produce in one minute if it is connected to a battery of 12 V?

Answer. Heat produced in a conductor: Consider a wire AB having a resistance 'R' connected across the terminals of a cell. Let V be the potential difference applied by cell across the ends of a wire.

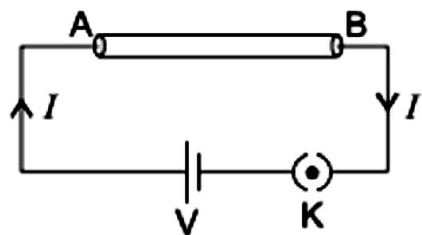

Let W be the work done in carrying the charge q across the conductor, then

$$V = \frac{W}{q} \text{ or } W = V \times q \quad (i)$$

but $q = I \times t$

So, $W = V \times It \quad (ii)$

This work done will appear in the form of heat produced in the wire, i.e.

$$H = VIt \quad (iii)$$

Using Ohm's law, $V = IR$

So, $H = (IR) It = I^2Rt$

This is the expression for the heat produced in the wire. This is called Joule's law of heating.

Heat produced in one minute

$$H = P \times t = 12 \text{ W} \times 60 \text{ s} = 720 \text{ J}$$

36. A piece of wire of resistance 20Ω is drawn out so that its length is increased to twice its original length. Calculate the resistance of the wire in the new Situation.

Answer.

Using, $R = \frac{\rho l}{A}$,

We have, $\frac{R_1}{R_2} = \frac{l_1}{A_1} \cdot \frac{A_2}{l_2}$

Given: $l_2 = 2l_1$

Volume of material will be conserved.

So, $A_1 l_1 = A_2 l_2$

$\therefore \frac{A_1}{A_2} = \frac{l_2}{l_1} = 2$

$$\frac{R_1}{R_2} = \frac{l_1}{l_2} \cdot \frac{l_1}{l_2} = \frac{l_1^2}{l_2^2} = \frac{1}{4}$$

$\therefore R_2 = 4R_1 = 80 \Omega$

37. (a) Two resistors R_1 and R_2 may form (i) a series combination or (ii) a parallel combination, and the combination may be connected to a battery of 6 volts. In which combination, will the potential difference across R_1 and across R_2 be the same and in which combination, will the current through R_1 and through R_2 be the same?
 (b) For the circuit shown in this diagram, calculate

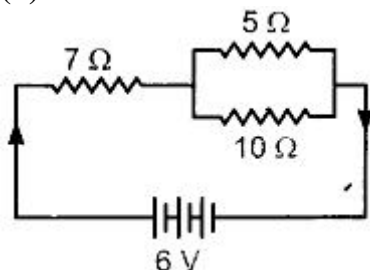

- (i) the resultant resistance.
 (ii) the total current.
 (iii) the voltage across 7Ω resistor.

Answer. (a) Potential difference across R_1 and R_2 is same in parallel combination of R_1 and R_2

and the current through R_1 and R_2 will be same when they are connected in series.

(b) (i) 5Ω and 10Ω are in parallel.

$$\text{So, } \frac{1}{R_1} = \frac{1}{5} + \frac{1}{10} = \frac{10+5}{50} = \frac{15}{50}$$

$$\Rightarrow R_1 = \frac{50}{15} \Omega = 3.33 \Omega$$

Since, 7Ω is in series with R_1

$$\begin{aligned} R_{eq} &= R_1 + 7 \\ &= 3.33 + 7 = 10.33 \Omega \end{aligned}$$

$$(ii) \text{ Total current drawn} = \frac{V}{R_{eq}}$$

$$I = \frac{6}{10.33} = 0.58 \text{ A}$$

$$(iii) \text{ Voltage across } 7 \Omega \text{ resistor} = I \times 7 = 0.58 \times 7 = 4.06 \text{ V}$$

.....

LIGHT REFLECTION AND REFRACTION

1. List four properties of the image formed by a plane mirror.

Answer. Properties of image formed by a plane mirror:

1. It is always virtual and erect.
2. Its size is equal to that of the object.
3. It is formed at the same distance behind the mirror as the object is in front of the mirror.
4. It is laterally inverted.

2. List four properties of the image formed by a convex mirror.

Answer. Properties of image formed by a convex mirror:

1. It is always formed behind the mirror, between the pole and its focus.
2. It is always virtual and erect.
3. Its size is always smaller than the object.
4. Magnification is always positive.

3. List four properties of the image formed by a concave mirror, when object is placed between focus and pole of the mirror.

Answer.

1. The image is formed behind the mirror.
2. It is enlarged, he. magnified.
3. It is virtual.
4. It is erect.

4. Redraw the given diagram and show the path of the refracted ray:

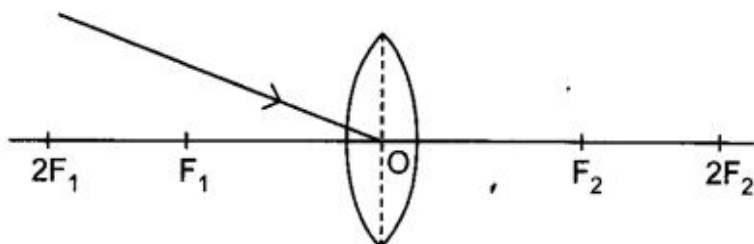

Answer.

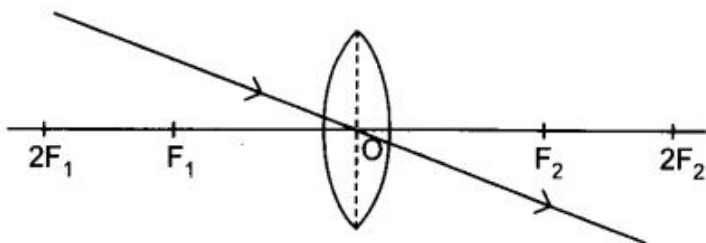

5. Redraw the given diagram and show the path of the refracted ray:

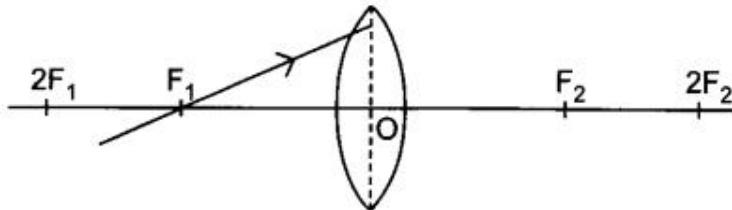

Answer.

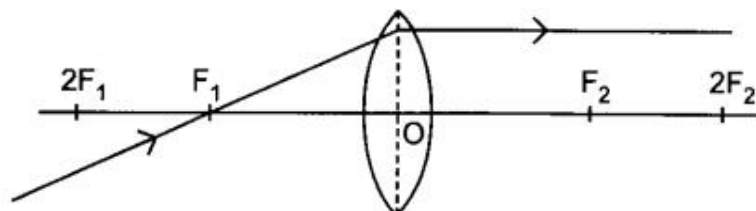

6. Draw the following diagram in your answer book and show the formation of image of the object AB with the help of suitable rays.

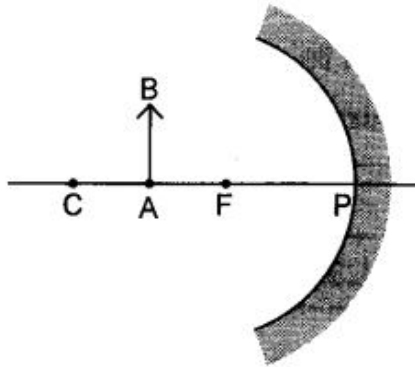

Answer.

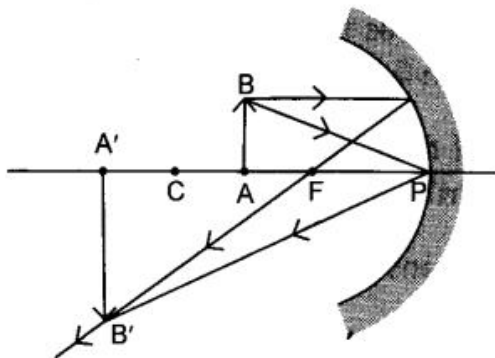

7. Which kind of mirrors are used in the headlights of a motor-car and why?

Answer. Concave mirror, to get the parallel beam of light.

8. Explain with the help of a diagram, why a pencil partly immersed in water appears to be bent at the water surface.

Answer. Light from different points on the pencil, immersed in water refracts and appears to come from a point above the original position.

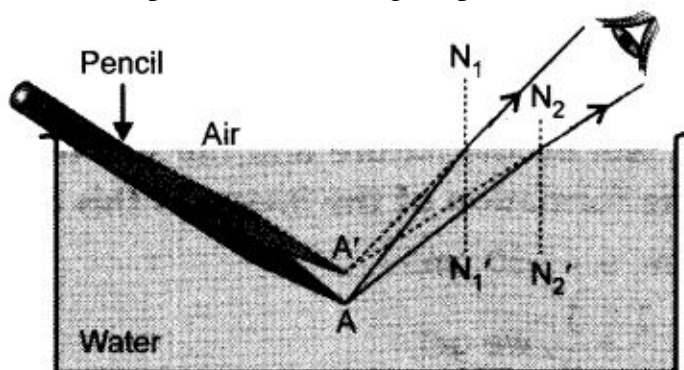

9. Name the type of mirror used in the following situations:

(i) Headlights of a car (ii) Rear-view mirror of vehicles (iii) Solar furnace Support your answer with reason.

Answer. Type of mirror used in

(i) Headlights of a car: Concave mirror Concave mirror is used because light from the bulb placed at the focus of it gets reflected and produces a powerful parallel beam of light to illuminate the road.

(ii) Rear view mirror of vehicles: Convex mirror

Convex mirror is used because it always produces a virtual, and erect image whose size is smaller than the object. Therefore it enables the driver to see wide field view of the traffic behind the vehicle in a small mirror.

(iii) Solar furnace: Concave mirror

Concave mirror has the property to concentrate the sunlight coming from sun along with heat radiation at its focus. As a result, temperature at its focus increases and the substance placed at the focal point gets heated to a high temperature.

10. A concave lens has focal length of 20 cm. At what distance from the lens a 5 cm tall object be placed so that it forms an image at 15 cm from the lens? Also calculate the size of the image formed.

Answer.

$$f = -20 \text{ cm}, h_o = 5 \text{ cm}, v = -15 \text{ cm}.$$

Using, $\frac{1}{f} = \frac{1}{v} - \frac{1}{u}$, we get

$$\frac{1}{u} = \frac{1}{v} - \frac{1}{f} = \frac{1}{-15} - \frac{1}{(-20)}$$

$$\frac{1}{u} = \frac{-20+15}{300} = -\frac{5}{300}$$

$$u = -60 \text{ cm}.$$

Since, $m = \frac{h_i}{h_o} = \frac{v}{u}$, we get

$$h_i = \frac{v}{u} \cdot h_o = \frac{(-15)}{(-60)} \times 5$$

$$= \frac{5}{4} = 1.25 \text{ cm}.$$

Image is diminished and virtual.

11. An object 50 cm tall is placed on the principal axis of a convex lens. Its 20 cm tall image is formed on the screen placed at a distance of 10 cm from the lens. Calculate the focal length of the lens.

Answer.

$$h_o = 50 \text{ cm},$$

$$h_i = 20 \text{ cm}, v = 10 \text{ cm}.$$

Using, $m = \frac{h_i}{h_o} = \frac{v}{u}$, we get

With sign convention,

$$u = v \frac{h_o}{h_i} = 10 \times \frac{50}{(-20)}$$

$$= -25 \text{ cm}.$$

Using, $\frac{1}{f} = \frac{1}{v} - \frac{1}{u}$, we get

$$\frac{1}{f} = \frac{1}{10} - \frac{1}{-25} = \frac{25+10}{250}$$

$$f = \frac{250}{35} = 7.14 \text{ cm}.$$

12. Draw the ray diagram in each case to show the position and nature of the image formed when the object is placed:

- (i) at the centre of curvature of a concave mirror
- (ii) between the pole P and focus F of a concave mirror
- (iii) in front of a convex mirror
- (iv) at 2F of a convex lens
- (v) in front of a concave lens

Answer.

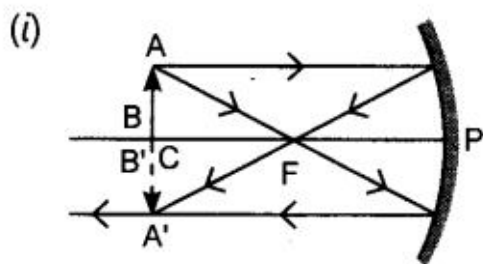

Nature of image: Real, inverted and same size image is formed at the centre of curvature.

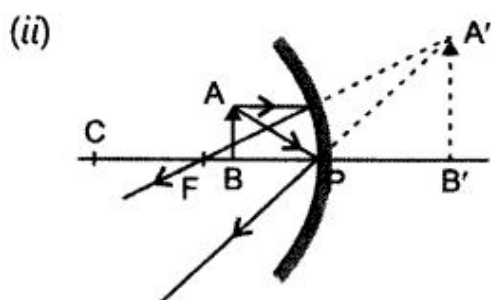

Nature of image: Virtual, enlarged and erect image is formed behind the mirror.

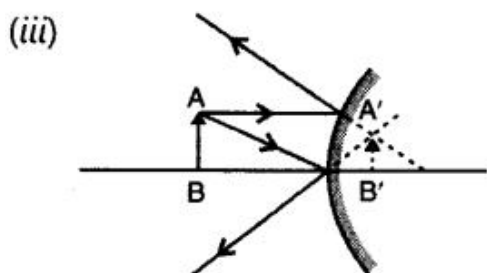

Nature of image: Virtual, erect and diminished, image is formed behind the mirror.

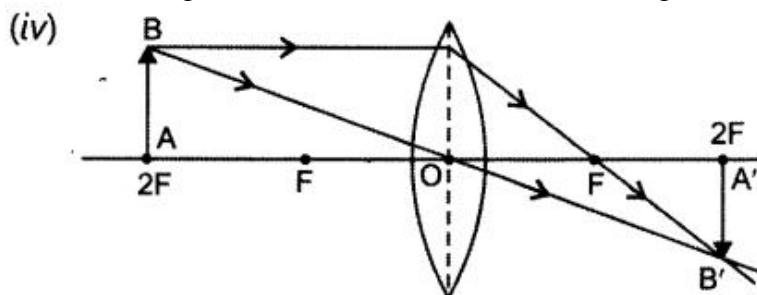

Nature of image: Real, inverted and size to size, image is formed at 2F on the other side of lens.

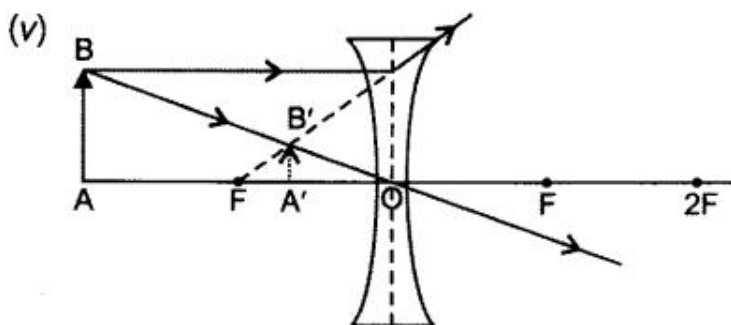

Nature of image: Virtual, erect and diminished image is formed between O and F on the same side of object.

13. If a light ray IM is incident on the surface AB as shown, identify the correct emergent ray.

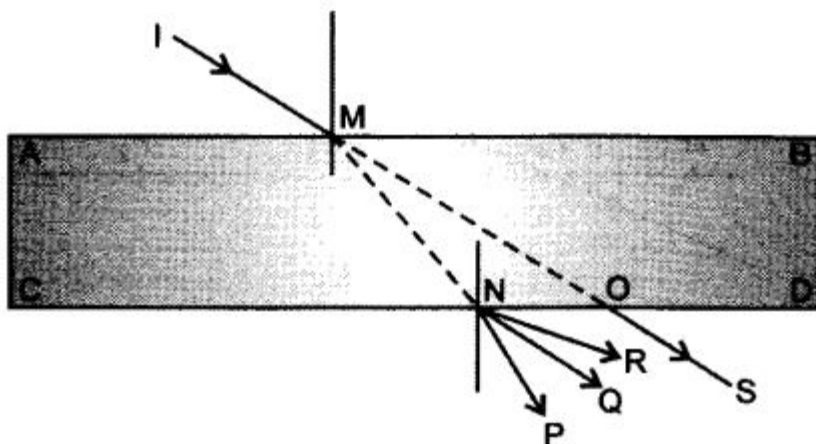

Answer. Ray NQ, as it has to be parallel to ray OS.

14. Draw ray diagrams to represent the nature, position and relative size of the image formed by a convex lens for the object placed:

(a) at $2F_1$

(b) between F_1 and the optical centre O of lens:

Answer.

(a) At $2F_1$

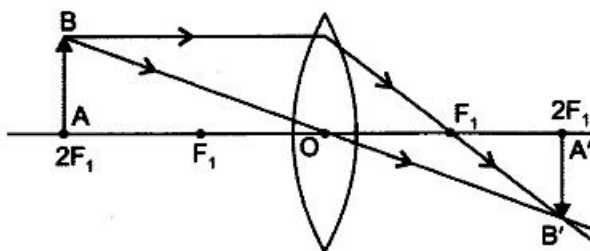

Nature: Real, inverted, size to size.

Position: At $2F$.

(b) Between F_1 and the optical centre O of lens

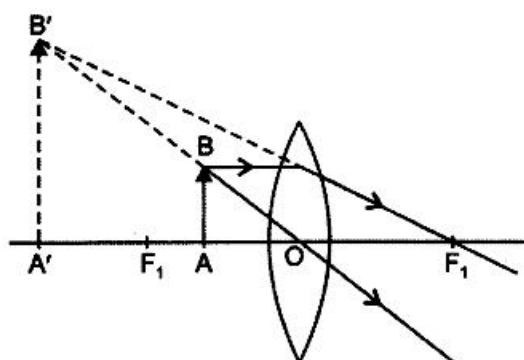

Nature: Virtual, erect, enlarged.

Position: On the same side of the lens.

15. A ray of light, incident obliquely on a face of a rectangular glass slab placed in air, emerges from the opposite face parallel to the incident ray. State two factors on which the lateral displacement of the emergent ray depends.

Answer. Lateral displacement depends on the:

angle of incidence,
thickness of slab, and

refractive index of the material. (any two)

16. An object 2 cm in size is placed 30 cm in front of a concave mirror of focal length 15 cm. At what distance from the mirror should a screen be placed in order to obtain a sharp image? What will be the nature and the size of the image formed? Draw a ray diagram to show the formation of the image in this case.

Answer.

$$f = -15 \text{ cm}, h_o = 2 \text{ cm}, u = -30 \text{ cm}.$$

Using, $\frac{1}{f} = \frac{1}{v} + \frac{1}{u}$, we get

$$\frac{1}{v} = \frac{1}{f} - \frac{1}{u} = \frac{1}{-15} - \frac{1}{-30}$$

$$= \frac{2-1}{-30} = \frac{1}{-30}$$

$$\Rightarrow v = -30 \text{ cm}$$

So, screen should be placed at a distance of 30 cm on the same side of the object in order to obtain a sharp image.

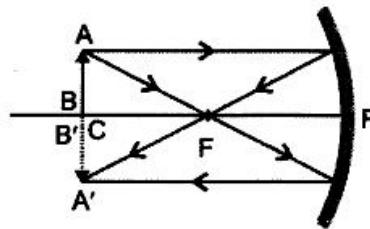

Since, $|v| = |u| = 2f$, it means that the object is placed at the centre of curvature (C) of a concave mirror, the image formed is at the centre of curvature, real and inverted and of the same size as the object.

17. An object 2 cm high is placed at a distance of 64 cm from a white screen. On placing a convex lens at a distance of 32 cm from the object it is found that a distinct image of the object is formed on the screen. What is the focal length of the convex lens and size of the image formed on the screen? Draw a ray diagram to show the formation of the image in this position of the object with respect to the lens.

Answer. Since, object-screen distance is double of object-lens separation, the object is at a distance of $2f$ from the lens and the image should be of the same size of the object.

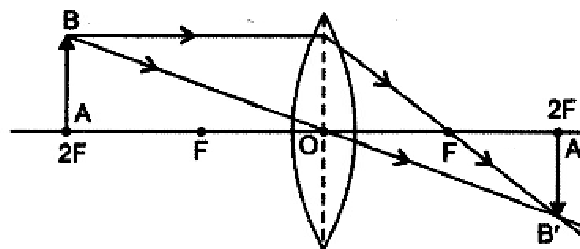

$$\text{So, } 2f = 32 \Rightarrow f = 16 \text{ cm}$$

$$\text{Height of image} = \text{Height of object} = 2 \text{ cm}.$$

18. Why does a ray of light bend when it travels from one medium into another?

Answer. Due to change in velocity in the medium and to reduce the time taken to travel the same.

19. Redraw the diagram given below in your answer book and show the direction of the light ray after refraction from the lens.

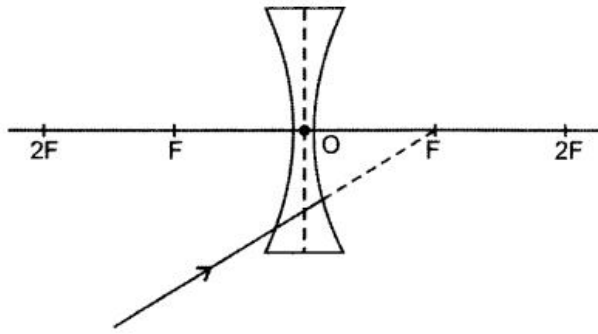

Answer.

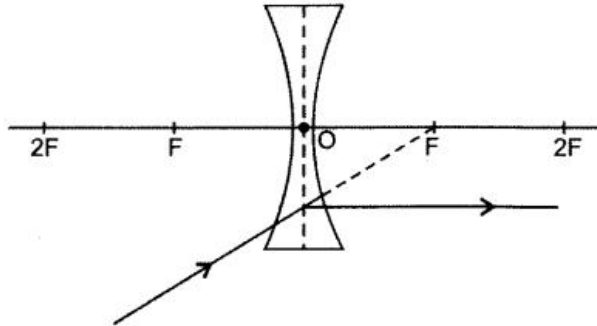

20. A convex lens has a focal length of 10 cm. At what distance from the lens should the object be placed so that it forms a real and inverted image 20 cm away from the lens? What would be the size of the image formed if the object is 2 cm high? With the help of a ray diagram show the formation of the image by the lens in this case.

Answer.

$f = +10$ cm, $v = +20$ cm as image is real and inverted. Height of the object = 2 cm. (Say +ve)

Using, $\frac{1}{f} = \frac{1}{v} - \frac{1}{u}$, we get

$$\frac{1}{u} = \frac{1}{v} - \frac{1}{f}$$

$$= \frac{1}{+20} - \frac{1}{10} = \frac{+1-2}{20} = -\frac{1}{20}$$

$$\therefore u = -20 \text{ cm } (= 2f)$$

Object is placed at $2F$, image is also formed at $2F$ on the other side of the lens. So, image will be of the same size as the object as $|u| = |v|$ and, therefore, the height of the image will be 2 cm.

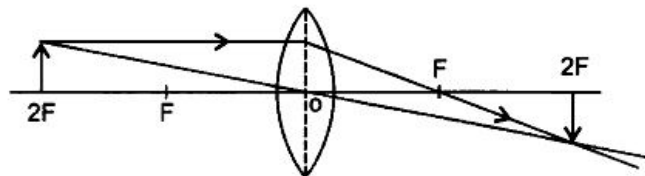

21. The refractive index of water is 1.33 and the speed of light in air is $3 \times 10^8 \text{ ms}^{-1}$. Calculate the speed of light in water.

Answer.

$$\text{Since, refractive index} = n = \frac{\text{Speed of light in vacuum}}{\text{Speed of light in medium}} = \frac{c}{v}$$

$$\begin{aligned} \text{we get, } v &= \frac{c}{n} = \frac{3 \times 10^8}{1.33} = \frac{3 \times 10^8}{4} \times 3 \\ &= 2.25 \times 10^8 \text{ ms}^{-1}. \end{aligned}$$

22. The refractive index of glass is 1.50 and the speed of light in air is $3 \times 10^8 \text{ ms}^{-1}$. Calculate the speed of light in glass.

Answer.

Since refractive index = n

$$= \frac{\text{Speed of light in vacuum}}{\text{Speed of light in the medium}} = \frac{c}{v}$$

$$\text{we have, } v = \frac{c}{n} = \frac{3 \times 10^8}{1.50} = 2 \times 10^8 \text{ ms}^{-1}.$$

23. For which position of the object does a convex lens form a virtual and erect image? Explain with the help of a ray diagram.

Answer. When the object is placed between the focus and the optical centre, a virtual and erect image is formed.

Position of Object	Position of Image	Nature of Image	Ray Diagram
Between F and optical centre	On the same side of the lens	Virtual, erect and enlarged	

24. In an experiment with a rectangular glass slab, a student observed that a ray of light incident at an angle of 55° with the normal on one face of the slab, after refraction strikes the opposite face of the slab before emerging out into air making an angle of 40° with the normal. Draw a labelled diagram to show the path of this ray. What value would you assign to the angle of refraction and angle of emergence?

Answer.

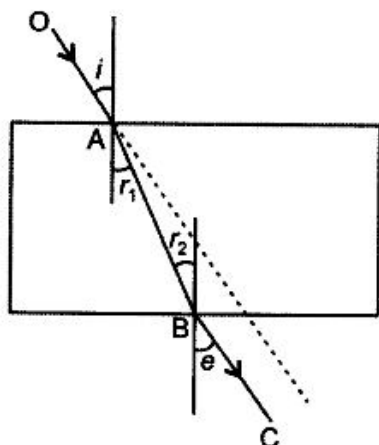

OA – incident ray

i is angle of incidence = 55°

Given $r_2 = 40^\circ$

r_1 and r_2 are alternate interior angles,

$\therefore \angle r_1 = \angle r_2 = 40^\circ$

So, angle of refraction = 40°

Since, the emergent ray is parallel to the incident ray, the angle of emergent must be equal to angle of incidence, i.e. $\angle e = \angle i = 55^\circ$

25. At what distance should an object be placed from a convex lens of focal length 18 cm to obtain an image at 24 cm from it on the other side. What will be the magnification produced in this case?

Answer.

$$f = +18 \text{ cm}, v = 24 \text{ cm}$$

$$\text{Using, } \frac{1}{f} = \frac{1}{v} - \frac{1}{u}, \text{ we get, } \frac{1}{u} = \frac{1}{v} - \frac{1}{f}$$

$$= \frac{1}{24} - \frac{1}{18} = \frac{3-4}{72}$$

$$\Rightarrow u = -72 \text{ cm.}$$

Object should be kept at a distance of 72 cm on the left side of the convex lens.

$$\text{Magnification, } m = +\frac{v}{u} = \frac{24}{-72} = \frac{-1}{3}$$

Image is inverted, real and diminished.

26. What is the nature of the image formed by a concave mirror if the magnification produced by the mirror is +3?

Answer. Positive sign of magnification indicates that image is virtual, erect and enlarged.

27. Between which two points of a concave mirror should an object be placed to obtain a magnification of -3?

Answer. Negative sign of magnification indicates that image is real and inverted. Also size of image is enlarged. So, object must be positioned between F and 2F, i.e. C.

28. Define and show on a diagram, the following terms relating to a concave mirror:

(i) Aperture

(ii) Radius of curvature

Answer. (i) The diameter of the reflecting surface of the mirror is called aperture.

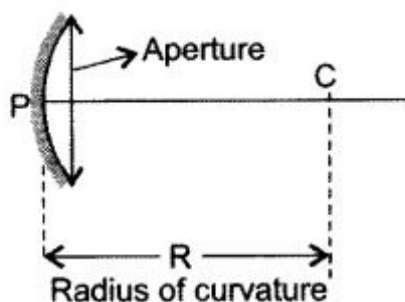

(ii) The radius of the sphere of which the reflecting surface of the spherical mirror forms a part is called the radius of curvature of the mirror.

29. How far should an object be placed from a convex lens of focal length 20 cm to obtain its image at a distance of 30 cm from the lens? What will be the height of the image if the object is 6 cm tall?

Answer.

$$f = + 20 \text{ cm}, v = + 30 \text{ cm}$$

$$\text{Using, } \frac{1}{f} = \frac{1}{v} - \frac{1}{u}$$

$$\begin{aligned} \text{we get, } \frac{1}{u} &= \frac{1}{v} - \frac{1}{f} \\ &= \frac{1}{30} - \frac{1}{20} = \frac{2-3}{60} = \frac{-1}{60} \end{aligned}$$

$$\therefore u = -60 \text{ cm.}$$

Object should be placed at a distance of 60 cm on the left side of the convex lens.

$$\text{Using, } m = \frac{h_i}{h_o} = + \frac{v}{u} \text{ we get,}$$

$$\begin{aligned} \text{Height of the image, } h_i &= + \frac{v}{u} h_o \\ &= + \frac{30}{(-60)} \times 6 = -3 \text{ cm} \end{aligned}$$

Negative sign shows that the image is inverted and real.

30. The image of an object placed at 60 cm in front of a lens is obtained on a screen at a distance of 120 cm from it. Find the focal length of the lens. What would be the height of the image if the object is 5 cm high?

Answer.

$$u = -60 \text{ cm}, v = +120 \text{ cm}$$

$$\text{Using, } \frac{1}{f} = \frac{1}{v} - \frac{1}{u}, \text{ we get}$$

$$\frac{1}{f} = \frac{1}{120} - \frac{1}{-60} = \frac{1+2}{120}$$

$$\Rightarrow f = 40 \text{ cm}$$

$$m = \frac{v}{u} = \frac{h_i}{h_o}$$

$$\begin{aligned} \therefore h_i &= h_o \times \frac{v}{u} \\ &= 5 \times \frac{120}{60} = 10 \text{ cm.} \end{aligned}$$

31. Define the focus of a concave mirror. If the radius of curvature of a convex mirror is 30 cm, what would be its focal length?

Answer. The point on the principal axis where all the rays parallel to it meet after reflection is called focus. Since, $R = 30 \text{ cm}$ and $f=R/2$ we have, $f=+15 \text{ cm}$ for a convex mirror.

32. **Distinguish between a real and a virtual image of an object. What type of image is formed (i) by a plane mirror, (ii) on a cinema screen?**

Answer. If light rays after reflection converge to a point to form an image on its own, it is called a real image. If they are diverging, then they form a virtual image. Real image can be obtained on a screen, while a virtual image cannot be.

(i) Plane mirror forms virtual image.

(ii) On cinema screen, real image is formed.

33. **Draw a ray diagram and also state the position, the relative size and the nature of image formed by a concave mirror when the object is placed at the centre of curvature of the mirror.**

Answer.

Position of object	Position of image	Nature of image	Ray diagram
At C	At C	Real, inverted and of same size.	

34. **Define 'refractive index of a transparent medium.' What is its unit? Which has a higher refractive index, glass or water?**

Answer. The ratio of the speed of light in the free space (c) to the speed of light in given medium (v) is called its refractive index.

$$n = c/v.$$

It has no unit. Glass has more refractive index than water.

35. **An object is placed between infinity and the pole of a convex mirror. Draw a ray diagram and also state the position, the relative size and the nature of the image formed.**

Answer.

Position of Object	Position of Image	Nature of Image	Ray Diagram
Between infinity and pole P of the mirror	Between P and F and behind the mirror	Virtual, erect and diminished	

36. (a) **What is meant by 'power of a lens'?**

(b) **State and define the S.I. unit of power of a lens.**

(c) **A convex lens of focal length 25 cm and a concave lens of focal length 10 cm are placed in close contact with each other. Calculate the lens power of this combination. [All India]**

Answer. (a) Power of a Lens: The ability of a lens, to converge or diverge the ray of light after refraction, is called power (P) of the lens. It is defined as the reciprocal of the focal length, i.e.

$$P = \frac{1}{f}.$$

(b) The SI unit of power of a lens is 'diopetre'. A lens of focal length 100 cm has a power of 1

diopetre, i.e. 1 diopetre = 1m⁻¹.

(c) Power of the combination, $P = P_1 + P_2 = \frac{100}{25} + \frac{100}{-10} = 4 - 10 = -6D$

37. What is the principle of reversibility of light? Show that the incident ray of light is parallel to the emergent ray of light when light falls obliquely on a side of a rectangular glass slab.

Answer. The final path of the ray of light after reflections or refractions is reversed; the ray retraces its entire path. This principle is called reversibility of light.

For rectangular glass slab,

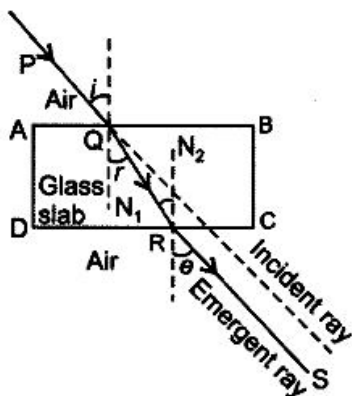

Apply Snell's law at Q on the side AB

$$\frac{\sin i}{\sin r} = \frac{n_g}{n_a} = {}_a n_g \quad \dots (1)$$

Apply Snell's law at R on the side DC

$$\frac{\sin r}{\sin e} = \frac{n_a}{n_g} = {}_g n_a \quad \dots (2)$$

$$[\angle N_1QR = \angle QRN_2 \\ = r, \text{ alt. angles}]$$

If the ray retraces its entire path, then for reversed ray

$$\frac{n_g}{n_a} = \frac{\sin e}{\sin r} = {}_a n_g \quad \dots (3)$$

Multiplying (2) by (3), we get

$$\frac{\sin r}{\sin e} \times \frac{\sin e}{\sin r} = {}_g n_a \times {}_a n_g = 1$$

Due to this property, we say refraction of light is reversible.

From (1) and (3),

$$\frac{\sin i}{\sin r} = \frac{\sin e}{\sin r} \quad \dots(4)$$

$$\Rightarrow \sin i = \sin e$$

$$\text{or} \quad \angle i = \angle e$$

Hence incident ray PQ is parallel to the emergent ray RS when light falls obliquely on a side of rectangular glass slab.

38. What is understood by lateral displacement of light? Illustrate it with the help of a diagram.

List any two factors on which the lateral displacement of a particular substance depends.

Answer. Lateral displacement is the perpendicular distance between the incident ray produced and the emergent ray. Lateral displacement in the diagram is BL. The lateral displacement depends on the thickness of the slab, the incident and refraction angles.

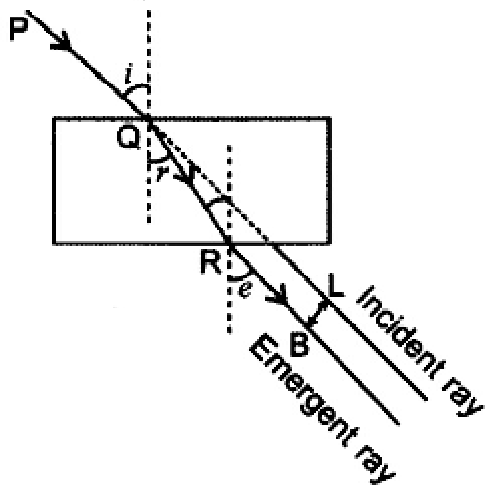

39. (a) If the image formed by a lens is diminished in size and erect, for all positions of the object, what type of lens is it?

(b) Name the point on the lens through which a ray of light passes undeviated.

(c) An object is placed perpendicular to the principal axis of a convex lens of focal length 20 cm. The distance of the object from the lens is 30 cm. Find (i) the position (ii) the magnification and (iii) the nature of the image formed. [Delhi]

Answer. (a) Concave lens.

(b) Optical centre.

(c) $u = -30$ cm, $f = 20$ cm

(i) Using, $\frac{1}{f} = \frac{1}{v} - \frac{1}{u}$ we get,

$$\frac{1}{v} = \frac{1}{f} + \frac{1}{u} = \frac{1}{20} + \frac{1}{-30} = \frac{3-2}{60}$$

$$\Rightarrow v = 60 \text{ cm}$$

Image is formed at a distance of 60 cm from the lens on the right side.

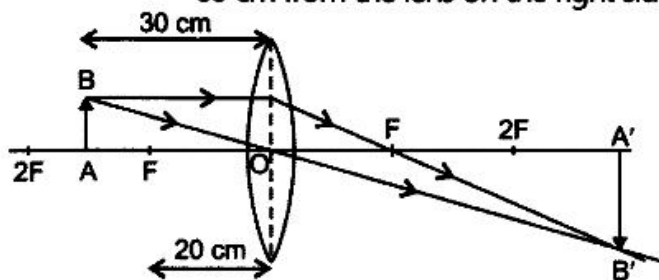

$$(ii) m = \frac{v}{u} = \frac{60}{-30} = -2$$

So, image is inverted and double the size of the object.

(iii) Image is real as $v > 0$, inverted and enlarged.

40. (a) Draw a ray diagram to show the formation of image of an object placed between infinity and the optical centre of a concave lens.

(b) A concave lens of focal length 15 cm forms an image 10 cm from the lens. Calculate

- (i) the distance of the object from the lens.
- (ii) the magnification for the image formed.
- (iii) the nature of the image formed. [All India]

Answer. (a) Image formation when the object is at any position between infinity and optical centre:

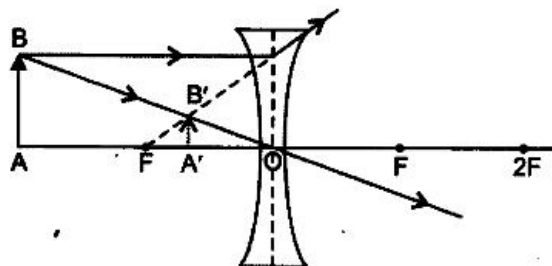

Position of image: Between F and optical centre

Nature of image: Virtual, erect and diminished.

(b) $f = -15 \text{ cm}$ $v = -10 \text{ cm}$

(i) Using, $\frac{1}{f} = \frac{1}{v} - \frac{1}{u}$, we get

$$\frac{1}{u} = \frac{1}{v} - \frac{1}{f} = \frac{1}{-10} - \frac{1}{-15} = -\frac{1}{30}$$

$\therefore u = -30 \text{ cm}$

Therefore the object is at 30 cm from the concave lens on its left side.

(ii) $m = \frac{-10}{-30} = \frac{1}{3}$

(iii) m is +ve, so image is erect. v is -ve, so image is virtual. As $m < 1$, image is diminished.

41. With the help of a ray diagram explain why a convex mirror is preferred for rear view mirrors in motor cars.

Answer. (i) It always forms a virtual, erect and diminished image.

(ii) The field of view increases while using a convex mirror as shown.

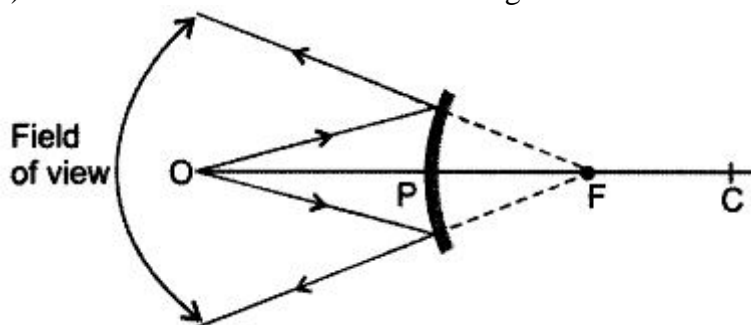

42. To instruct a ray diagram, we use two light rays which are so chosen that it is easy to know their directions after refraction from the lens. List these two rays and state the path of these rays after refraction. Use these two rays to locate the image of an object placed between 'F' and '2F' of a convex lens. [Foreign]

Answer. Two rays choose for refraction:

- (i) A ray of light parallel to the principal axis.
- (ii) A ray of light passing through the optical centre of a lens.

Path of these rays after refraction:

In case of convex lens, the first ray will pass through the principal focus on the other side of the lens.

In case of concave lens, the first ray will

- (a) appear to diverge or
- (b) appear to come from the principal focus positioned on the same side of the object.

The second ray emerge from the lens without any deviation in the path.

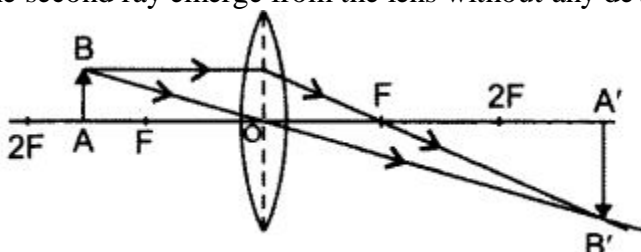

43. **List the sign conventions for reflection of light by spherical mirrors. Draw a diagram and apply these conventions in the determination of focal length of a spherical mirror which forms a three times magnified real image of an object placed 16 cm in front of it.**

Answer. Sign conventions for reflection of light by spherical mirror are:

1. The object is always placed to the left of the mirror.
2. All the distances parallel to the principal axis are always measured from the pole of the spherical mirror.
3. All the distances measured along the direction of incident light (along +ve x-axis), are considered to be positive.
4. Those distances measured opposite to the direction of incidence light (i.e. along -ve x-axis), are taken as negative.
5. The distances measured in upward direction, i.e. perpendicular to and above the principal axis (along +ve y-axis), are taken as positive.
6. The distances measured in the downward direction, (along -ve y-axis), i.e. perpendicular to and below the principal axis are taken as negative.

From the question

$$u = -16 \text{ cm}, m = -3 \text{ for real}$$

image

$$\text{But } m = -\frac{v}{u} = -3$$

$$\Rightarrow v = 3u = 3(-16) = -48 \text{ cm.}$$

Using mirror formula,

$$\frac{1}{f} = \frac{1}{v} + \frac{1}{u}$$

$$\text{We get, } \frac{1}{f} = \frac{1}{-48} + \frac{1}{-16}$$

$$= \frac{1}{-48} - \frac{1}{16} = \frac{-1-3}{48} = \frac{-4}{48} = \frac{-1}{12}$$

$$\text{or } f = -12 \text{ cm}$$

So, focal length of spherical mirror is 12 cm. Negative sign of focal length indicates that mirror is concave in nature.

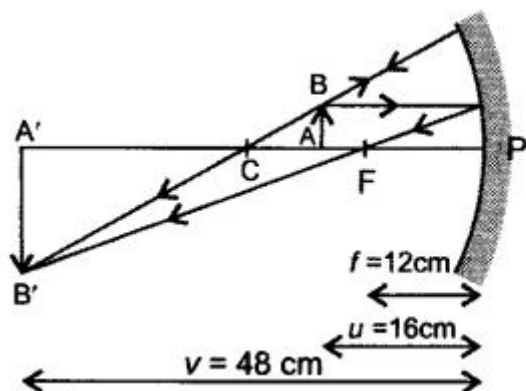

44. To construct a ray diagram, we use two light rays which are so chosen that it is easy to know their directions after reflection from the mirror. List these two rays and state the path of these rays after reflection. Use these rays to locate the image of an object placed between centre of curvature and focus of a concave mirror.

Answer. Rays which are chosen to construct ray diagram for reflection are:

- (i) A ray parallel to the principal axis and
- (ii) A ray passing through the centre of curvature of a concave mirror or appear to pass through the centre of curvature of convex mirror.

Path of these rays after reflections is:

- (i) After reflection, the first ray will pass through the principal focus of a concave mirror or appear to diverge in case of a convex mirror.
- (ii) After reflection, the second ray is reflected back along the same path.

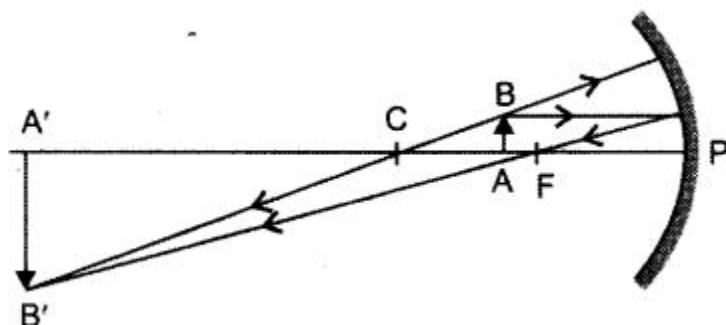

45. State the type of mirror preferred as (i) rear view mirror in vehicles, (ii) shaving mirror. Justify your answer giving two reasons in each case. [Delhi] ?

Answer. (i) Convex mirror (ii) Concave mirror

Justification:

- (i) Convex mirror is used as a rear view mirror because:
 - (a) it gives a wider field of view as it is curved outwards and
 - (b) it produces erect and diminished image of the traffic behind the driver of the vehicle.
- (ii) Concave mirror is used as a shaving mirror to see a large size image of the face. When the object lies in between pole and principal focus of a concave mirror, it forms a virtual, erect and enlarged image behind it.

46. List the sign conventions that are followed in case of refraction of light through spherical lenses. Draw a diagram and apply these conventions in determining the nature and focal length of a spherical lens which forms three times magnified real image of an object placed 16 cm from the lens.

Answer. Sign conventions for refraction of light through spherical lens are:

1. The object is always placed to the left of the lens so that incident light moves from left to right.
2. All distances are to be measured from the optical centre of the lens.

3. The distances measured in the direction of incident light (along +ve x-axis) will be taken as positive, while those measured to the left of the origin (along -ve x-axis) will be taken as negative.
4. All measurements of heights above the principal axis (along +ve y-axis) will be considered as positive while below it (along -ve y-axis) will be taken as negative.

- According to question,

$$u = -16 \text{ cm}, m = -3$$

(real image)

But $m = \frac{v}{u}$

$$= -3$$

$$\Rightarrow v = -3u$$

$$= -3 \times (-16)$$

$$= 48 \text{ cm.}$$

Using lens formula,

$$\frac{1}{f} = \frac{1}{v} - \frac{1}{u}$$

$$= \frac{1}{48} - \frac{1}{-16} = \frac{1}{48} + \frac{1}{16}$$

$$= \frac{1+3}{48} = \frac{4}{48} = \frac{1}{12}$$

$$\Rightarrow f = +12 \text{ cm}$$

So, focal length of the given spherical lens is 12 cm. The positive sign of focal length shows that the nature of spherical lens is convex.

Ray diagram:

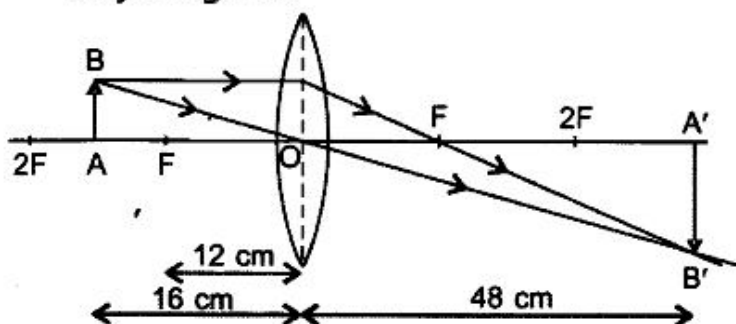

SOURCES OF ENERGY

- 1. List two nutrients that the slurry left behind in the biogas plant contain.**
Answer. Nitrogen and phosphorous.
- 2. Biogas is also known as gobar gas. Justify.**
Answer. Starting material for biogas is mainly cow dung. So, it is also known as gobar gas.
- 3. List two practical uses of biogas in rural areas.**
Answer. Practical uses of biogas in rural area are:
 1. It is an excellent fuel which burns without smoke with high heating capacity.
 2. It is also used for lighting.
- 4. Name any two fossil fuels.**
Ans. A good fuel is the one which
 - has high calorific value,
 - is non-polluting,
 - is easy to transport and easily available,
 - has moderate ignition temperature.
- 5. What is acid rain?**
Answer. Acid rain: The rain containing the acidic oxides such as oxides of carbon, nitrogen and sulphur.
- 6. Name one fuel used in nuclear reactor.**
Answer. Uranium-235.
- 7. Name any two elements that are used in fabricating solar cells.**
Answer. Germanium, Silicon.
- 8. Name the reaction responsible for large energy production in the sun.**
Answer. Nuclear fusion.
- 9. Write the name of the substance whose vapours are used to run the turbine of the generator of ocean thermal energy plant.**
Answer. Ammonia.
- 10. Mention the minimum temperature difference required between surface water and water at a depth of upto 2 km in an ocean thermal energy plant.**
Answer. 20 °C or 293 K in trapping geothermal energy
- 11. Name the part of a biogas plant where reactions take place in the absence of oxygen.**
Answer. Digester chamber.
- 12. Name the kind of energy possessed by wind and the device used to harness it.**
Answer. Kinetic energy, wind mill.
- 13. List two non-conventional sources of energy.**
Answer. Geothermal, solar, biomass, water, wind are the non-conventional sources of energy, (any two)
- 14. A black surface absorbs more heat radiations as compared to a white or a reflecting surface under identical conditions. List two solar devices which make use of this property in their design.**
Answer. Solar cooker, solar water heater.
- 15. Name any two elements that are used in fabricating solar cells.**
Answer. Germanium, Silicon.
- 16. Bio gas is considered to be a boon to the farmers. Give reasons.**
Answer.
 1. It is the source of excellent manure, rich in nitrogen and phosphorous which can be obtained from the biogas plant in addition to biogas.
 2. It provides the safe, efficient and profitable disposal method for bio-waste and sewage material.
- 17. Why a solar cooker painted black form outside?**
Answer. Black surface absorbs more heat as compared to white or reflecting surface under identical conditions.

18. **Define fuel. List any two characteristics that you would look for in a good fuel.**

Answer. A substance that produces useful energy when it burn or undergoes a chemical f or nuclear reaction. The fuel such as coal, wood, oil, or gas provides energy when burned. A good fuel is the one which produces a huge amount of heat on burning. It does not produce a lot of smoke and is easily available.

19. **State any three reasons to justify that LPG is considered as an ideal fuel.**

Answer. LPG is considered as an ideal fuel because

It is easy to store, handle and transport.

It produces large amount of heat on burning.

It does not leave any residue on burning,

20. **State any three advantages of charcoal over wood.**

Answer. Advantages of charcoal over wood

It has higher calorific value, i.e. higher heat generating efficiency.

Charcoal does not produce smoke on burning so it is a clean fuel.

It is easier to transport and ready to use in a convenient dry and broken-up form.

21. **Mention the purpose of blackening the interior of a solar cooker.**

Answer. The purpose of blackening the interior of a solar cooker is that the black surface absorbs more heat radiations of incident solar energy (about 98%) as compare to white or other light coloured surface

22. **Why do people oppose the construction of Tehri Dam on the river Ganga and Sardar sarover project on the river Narmada. (Or)**

Mention three disadvantage of producing hydroelectricity by constructing the dams.(Or)

List any three ways in which construction of dams for production of electricity adversely affects the environment of that place.

Answer.

1. Large area is required to build the dam that result rehabilitation of displaced people.

2. Large eco-systems are destroyed when submerged under the water in dams.

3. The vegetation which is submerged rots under anaerobic conditions and gives rise to large amounts of methane gas which leads to a green-house effect.

23. **Bio gas is an excellent fuel. Justify the statement by giving two reasons. Mention the main constituents of bio gas along with its percentage.**

Answer.

(i) It burns without smoke and leave no residue therefore causes no atmospheric pollution.

(ii)Its heating capacity is high, i.e. it has high calorific value. Main constituents of bio gas: The composition of bio gas varies depending upon the nature of organic matter feeding in'the digester and advanced waste treatment technology. The typical composition of bio gas is

Methane 50 – 75%

Carbon dioxide 25 – 50%

Nitrogen 0 – 10%

Hydrogen 0 – 1%

Hydrogen sulphide 0 – 3%

24. (a) **Define tidal energy.**

(b) **Explain how the tidal energy is harnessed and write one limitation of the use of tidal energy.**

Answer.

(a) Tidal energy: The energy produced by the surge of ocean water during high and low tides due to difference in sea-levels is called tidal energy. The high and low tides occur due to the gravitational pull of the moon. This causes enormous movement of water.

(b) Tidal energy is harnessed by constructing a dam near the shores. During the high tides water flows into the dam and during the low tides, water flows out. This flowing water rotates the turbine, present at the opening of the dam and produces electricity.

25. **Define process of nuclear fission. Writ the steps involved in generating electricity in a nuclear reactor.**

Answer. Nuclear Fission: The process in which a heavy nucleus (such as uranium, plutonium or thorium) is broken into two nearly equal fragments when bombarded with low-energy neutrons and a tremendous amount of energy is released. This process is called nuclear fission.

Steps involved in generating electricity:

1. The fuel rods full of uranium pellets are placed in a nuclear reactor chamber.
2. Low-energy neutrons are bombarded on uranium fuel rod.
3. A self-sustaining fission chain reaction starts that releases energy at a controlled rate.
4. With this heat the reactor converts water to steam at a high temperature and pressure.
5. This high temperature and pressure steam spins generator turbines producing electricity.
6. The steam cools back into water, which can then be used over again.

26. **Solar cooker takes more time as compared to the LPG to boil potato or rice, yet Kunal uses solar cooker for such type of cooking:**

(i) Why does Kunal uses Solar cooker instead of LPG? Give reasons for your Answer.

(ii) Name the phenomenon which is responsible for obtaining high temperature in solar cooker.

Answer.

(a)(i) There are no energy losses while cooking on the solar cooker as the food gets cooked in a controlled environment whereas cooking on the LPG leads to maximum percentage of energy loss.

(ii) Temperature controlled cooking retains the nutrient value of the food.

(iii) Using the solar cooker, LPG can be served which result reduction in the emission of CO₂.

(iv) It saves a lot of prestigious time which is normally consumed for cooking purpose.

(b) Greenhouse effect.

27. **Distinguish between renewable and non-renewable sources of energy. Also give an example of each of these sources.**

Answer.

Renewable Source of Energy	Non-renewable Source of Energy
(i) They are constantly supplied by nature and are inexhaustible.	(i) They do not renew or regenerate and are exhaustible.
(ii) Low cost of operation.	(ii) High cost of operation.
(iii) They produce little or no pollutants. Thus minimum impact on environment, e.g. wind energy, solar energy.	(iii) They produce a lot of pollutants, e.g. coal, petroleum, etc.

28. **State the principle of working of ocean thermal energy conversion plant.**

Explain how the plant works? Write one essential condition for it to operate properly.

Answer. Principle of working of OTEC: The water at the surface of the ocean is warmer than the water at deeper depths. This temperature difference can be used by Ocean Thermal Energy Conversion (OTEC) systems to generate electricity.

Working of OTEC:

- In OTEC plant, the energy of warm surface water is used to convert low boiling point liquid ammonia into gaseous state.
- The vapour of ammonia at high pressure is used to spin the turbines of generators converting the Ocean thermal energy to electricity.

- The used vapour pass through the condenser where cold water, pumped from the deeper parts of ocean condenses ammonia vapour back into a liquid.
- This process is repeated again and again ,to get continuous production of electricity.
Essential condition for it to operate properly: The temperature difference between the warmer water at the surface and colder water at depths up to 2 km should be 293 K (20°C) or more.

29. Mention why is it not possible to make use of solar cells to meet all our energy needs? State three reasons to support your Answer. Also mention three uses of solar cells.

Answer. It is not possible to make use of solar cells to meet all our energy needs because:

- (i) of limited availability of special grade semiconducting materials such as silicon and germanium.
- (ii) solar cells have lower efficiency as they depend entirely on intensity of solar radiation.
- (iii) the process of manufacturing of solar cells is very expensive, silver used for interconnection of cells in the panel further adds to the cost.

Uses of solar cells:

- (i) They provide electric power to satellites and space probes.
- (ii) They provide electric power to off-shore drilling platforms and light houses.
- (iii) TV relay stations or wireless transmission systems located in remote areas use solar panels to get electric power.

30. What are the advantages of nuclear energy?

Answer. Advantages of nuclear energy are:

- A small quantity of nuclear fuel is needed to produce a large amount of useful energy.
- Nuclear power plant produces less atmospheric pollution than thermal power plants, if the nuclear fission reaction is performed properly.
- Small amount of nuclear fuel can run a nuclear power plant over a long period of time.
There is no need of inserting the nuclear fuel in the nuclear reactor again and again in a short period as in case of thermal power plant.

31. What is a solar cell panel? Mention any three of its applications.

Answer. A large number of solar cells combined in an arrangement to obtain large electrical power is called solar cell panel.

Applications of solar cell panel are:

It provides the electric power for the:

- working of artificial satellites stationed in outer space,
- running of irrigation water pumps by the farmers in rural areas,
- street lighting in remote areas.

32. Out of two solar cookers, one was covered with a plane glass slab and the other was left open. Which of the two solar cookers will be more efficient and why?

Answer. The solar cooker which was covered with a plane glass slab would be more efficient. The glass lid allows the heat radiation from sun to enter the solar cooker but does not allow the reflected heat radiation to escape or go outside the box. Thus, heat trapped inside the box increases the temperature. Glass lid also reduces heat loss due to reflection.

33. List any three hazards of nuclear waste. How does the disposal of nuclear waste pose a problem for the plant and animal life?

Answer. Hazards of nuclear wastes are:

- i) Nuclear waste contains radioactive substances which emit harmful nuclear radiations.
- ii) There is a high risk of environmental contamination.
- iii) It is highly toxic.

Effect of nuclear waste on plant and animal life is:

The radiations emitted from the nuclear waste penetrate deep inside the human or animal body where they can damage biological cells thereby initiate cancer or causes genetic disease.

Increased mortality of plants, soil invertebrates and mammals and reproductive losses in plants and animals have also been observed.

34. (a) **Charcoal is a better fuel than wood. Why? .**
 (b) **How does biogas plant help to reduce the problem of pollution?**
Answer.
 (a) Charcoal is considered to be a better fuel than wood because:
 i) It burns without flames.
 ii) It is comparatively smokeless.
 iii) It has higher calorific value, i.e. higher heat generating efficiency than wood.
 (b) Biogas plant helps to reduce the problem of pollution in the following ways.
 i) It provides better sanitation due to safe disposal of bio-waste and sewage material.
 ii) Biogas obtained from this plant produces less smoke on burning. (Hi) The residue left can be used as a manure which can be used as an alternative of fertilizers. Thus, it prevents soil and water from degradation.
35. (a) **What is geothermal energy?**
 (b) **What are the advantages of wind energy?**
Answer.
 (a) The heat energy obtained from the molten rocks formed in the deeper hot regions inside the earth are called geothermal energy.
 (b) Advantages of wind energy are:
 a) It is an inexhaustible source of energy.
 b) It does not cause any environmental pollution.
 c) It is available at free of cost.
36. (a) **How does construction of dams across the river get linked with production of greenhouse gases?**
 (b) **How do technological inputs improve the efficiency of biomass fuels?**
Answer.
 (a) A vast variety of plants get submerged in water, rot under anaerobic conditions and produce large amount of greenhouse gases such as methane.
 (b) Traditional uses of biomass fuels are not only efficient but they also produce a lot of pollutants which are hazardous to health. Therefore, technological inputs are necessary to improve the efficiency of these fuels and make them environment friendly. With the help of technology, smokeless chulhas and biogas plants have been designed.
37. **Mention any four limitations in harnessing wind energy on a large scale.**
Answer. Limitations in harnessing wind energy are:
 a) Speed of wind is not available at all time and at all places.
 b) To establish the wind energy farm, a large area of land is needed.
 c) Speed of wind should be higher than 15 km/h to harness the wind energy.
 d) Construction of windmill and its installation is very expensive.
38. **What happens when wood is burnt in a limited supply of oxygen? Name the residue left behind after the reaction and state two advantages of using this residue as a fuel over wood.**
Answer. When wood is burnt in a limited supply of oxygen, volatile materials present in it get removed and cooled to get wood tar and wood gas.
 The black residue left behind after the reaction is known as charcoal. Advantages of using charcoal as a fuel over wood are:
 Burning of charcoal does not produce smoke. On the other hand, wood produces a lot of smoke on burning.
 For a given quantity, charcoal produces ,more heat than wood.
39. **Name four gases commonly present in biogas. State two advantages of using this gas over fossil fuels.**
Answer. Methane, carbon dioxide, hydrogen and hydrogen sulphide.
 Advantages of using biogas over fossil fuels are:
 Biogas burns without smoke, leaves no residue unlike coal.
 Biogas is cheaper as compared to fossil fuels.

40. **How are the wastes produced in nuclear power plants different from those produced in a thermal power plants ? What happens to the waste of a nuclear power plant?**

Answer. The waste obtained from nuclear power plants is highly radioactive in nature which emits harmful radiations, whereas waste produced in a thermal power plant is non-radioactive.

Management of nuclear waste is given as follows:

Some products of nuclear waste are buried in sealed steel/lead containers for a long term storage, buried under the ground or dumped in vacated coal mines.

Other waste products transform into less harmful products or to products with a shorter half life.

41. **In a solar cooker, the following arrangements are made. Write one function of each arrangement.**

(a) **The box is made of insulating material such as plastic or wood.**

(b) **The inner walls of the box are painted black.**

(c) **The box is covered with a transparent glass sheet.**

(d) **A plane mirror is hinged at an angle at the top of the box.**

Answer.

(a) To avoid loss of heat from solar cooker to the surroundings.

(b) Black surface absorbs more heat radiations of incident energy.

(c) Transparent glass sheet does not allow the reflected heat radiation to go outside the box.

(d) To increase the amount of solar energy incident on the transparent glass sheet.

42. **Describe how hydro energy can be converted into electrical energy. Write any two limitations of hydro energy.**

Answer. Conversion of hydro energy into electrical energy

- High rise dams are constructed on the river to obstruct the flow of water to collect it at a suitable height. The stored water has a lot of potential energy.
- The water from a suitable height is allowed to fall on the blades of a turbine located at the bottom of a dam through a pipe.
- Kinetic energy of flowing water rotates the turbine rapidly. Rotation of turbine helps the armature coil of generator to rotate rapidly in the magnetic field. Thus, hydroelectricity is generated.

Limitations of hydro energy:

(i) All river-sites are not suitable for construction of dams.

(ii) Large ecosystems are destroyed when submerged under the water in dam.

.....

HEREDITY AND EVOLUTION

1. **What is a gene?**

Answer. Gene is the unit of inheritance. Gene is the part of a chromosome which controls the appearance of a set of hereditary characteristics.

2. **What is meant by analogous organs? Taking a suitable example, explain how they support the theory of Organic Evolution.**

Answer. Analogous organs are those organs which have different basic structural design and developmental origin but have similar appearance and perform similar functions.

Example: The wings of birds and bats look similar but have different design in their structure. They have a common function of flying but their origins are not common. So, birds and bats are not closely related.

3. **What is a sex chromosome?**

Answer. Sex chromosome is a chromosome that operates in the sex-determining mechanism of a species. Many animals have two different types of sex chromosomes. For example, in human there is a large X chromosome and a much smaller Y chromosome.

4. **Define 'evolution'. Describe Darwin's theory of evolution.**

Answer. Evolution is the sequence of gradual changes which take place in the primitive organisms over millions of years and new species are produced. Since, the evolution is of the living organisms, so it is called 'Organic Evolution'.

Darwin's theory of Evolution: Charles Robert Darwin gave the theory of evolution in his famous book, 'The Origin of Species'. The theory of evolution proposed by Darwin is known as 'The Theory of Natural Selection'. It is also called 'Darwinism'.

According to Darwin's theory of evolution:

- a) There is natural variation within any population and some individuals have more favourable variations than others.
- b) Population remains fairly constant even though all species produce a large number of off springs.
- c) This is due to 'competition' or struggle for existence between same and different species.
- d) The struggle for survival within population eliminates the unfit individuals and those with 'favourable variations' survive and pass on these variations to their progeny to continue. This is called natural selection.
- e) The favourable variations are accumulated over a long time period leading to the origin of a new species.

5. **"The sex of the children is determined by what they inherit from their father and not their mother." Justify.**

Answer. It is because a child who inherits an X chromosome from her father will be a girl and one who inherits a Y chromosome from his father will be a boy. But all children inherit a X chromosome from their mother regardless of whether they are boys or girls.

6. **Define variation in relation to a species. Why is variation beneficial to the species?**

Answer. Variation refers to the differences in the characters or traits among the individuals of a species. Variations are beneficial to the species because:

- a) They enable the organisms to adapt themselves in changing environment.
- b) Variations form the basis of heredity.
- c) They form the raw materials for evolution and development of new species.

7. **Describe briefly four ways in which individuals with a particular trait may increase in a population.**

Answer. The four ways in which individuals with a particular trait may increase in a population are as follows:

- a) Sexual reproduction results into variations.
- b) The individuals with special traits survive the attack of their predators and multiply while the other will perish.
- c) Genetic drift provides diversity without any adaptation

d) Variations in the species may lead to increased survival of the individuals.

8. **What are fossils? What do they tell us about the process of evolution?**

Answer. The remains of dead plants and animals which were buried under the rocks millions of years ago are called fossils.

Fossils tell us about the process of evolution. The fossils of different organisms have some features similar to one species while some features are similar to the other species. In this way, they show the link between two species. They tell us that one species evolves from the other.

9. **Distinguish between acquired and inherited traits by giving one example of each. Why are traits acquired during the lifetime of an individual not inherited?**

Answer. Acquired trait is a particular characteristic that is developed during the lifetime of an individual. Such characteristics are not genetically controlled and cannot be passed on to the next generation. Example: Loss of weight due to starvation.

Inherited trait is the transmission of particular characteristics from parents to their off springs, generation to generation. Such traits are genetically determined characteristic that distinguishes a person.

Example: Colour of skin.

The acquired traits cannot change the DNA of the germ cells. Therefore, the acquired traits cannot be inherited over generations during the lifetime of an individual.

10. **The human beings who look so different from each other in terms of colour, size and looks are said to belong to the same species. Why? Justify your answer.**

Answer. Human beings are said to belong to the same species because of the following reasons:
DNA studies.

Number of chromosome is same,

All have a common ancestor.

They interbreed among themselves to produce fertile young ones of their own kind.

11. **Explain the mechanism of sex determination in humans.**

Or

With the help of a flow chart explain in brief how the sex of a newborn is genetically determined in human beings. Which of the two parents, the mother or the father, is responsible for determination of sex of a child?

Answer. Mechanism of Sex Determination in Human Beings:

In human beings, the sex of the individual is genetically determined.

- Sex determination is the process by which sex of a new born individual can be determined.
- Human beings have 1 unpaired sex chromosome. Sex chromosome of male is XY and of female is XX.
- Sex of a child depends on what happens at fertilisation.

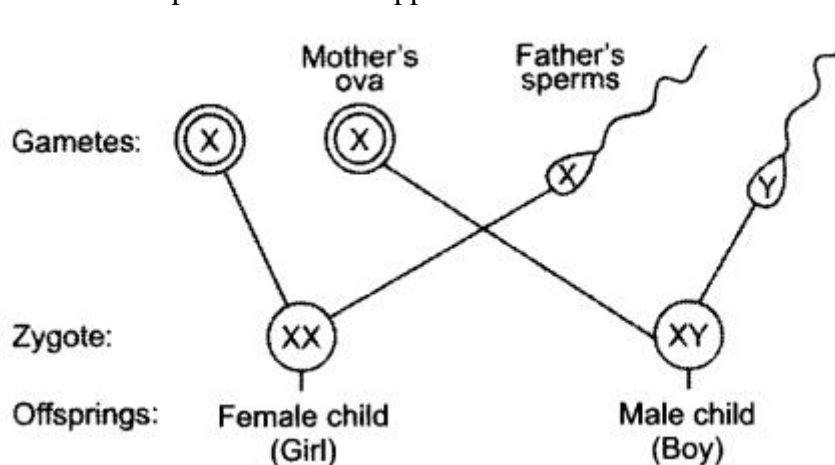

Thus, father is responsible for the determination of the sex of a child.

12. **Give one example each of characters that are inherited and the ones that are acquired in humans. Mention the difference between the inherited and the acquired characters. Answer.**

Eye colour or hair colour of a person is an example of inherited character whereas, body weight is

an example of acquired character.

The basic difference between inherited and acquired character is that inherited character is passed on from parent to offspring and acquired characters are acquired by an individual during his lifetime depending upon his lifestyle.

13. How is the equal genetic contribution of male and female parents ensured in the progeny?

Answer. During sexual reproduction, a female gamete or egg cell fuses with a male gamete or sperm cell which are haploid to form zygote. Zygote is diploid which contains 23 chromosomes from mother and 23 from father. In this way, an equal genetic contribution of male and female parents is ensured in the progeny.

14. What evidence do we have for the origin of life from inanimate matter?

Answer. Stanley L. Miller and Harold C. Urey provided evidence regarding origin of life from inanimate matter. They assembled an atmosphere similar to that existed on early earth. The atmosphere had molecules like ammonia, methane and hydrogen sulphide, but no oxygen and kept over water at temperature just below 100°C. Sparks were passed through the mixture of gases. At the end of a week, 15% carbon from methane had been converted to simple compounds of carbon like amino acids which make-up protein molecules. So, life arose afresh on earth.

15. Explain the terms: (i) Speciation (ii) Natural selection

Answer. (i) Speciation is the evolution of reproductive isolation among once-interbreeding populations, i.e. the development of one or more species from an existing species.

(ii) Natural selection is the process, according to Darwin, which brings about the evolution of new species of animals and plants.

16. Explain with examples how the following are evidences in favour of evolution in organisms. (i) Homologous organs (ii) Analogous organs (iii) Fossils

Answer. (i) Forelimb of human and bird are homologous organs. They have same structural design and developmental origin but they have different functions and appearance. Homologous organs help us to understand that the organism has evolved from a common ancestor. The more common characteristics the two species have, the more closely they are related.

(ii) Analogous organs are those organs design and developmental origin but have similar appearance and perform similar functions.

Example: The wings of birds and bats look similar but have different design in their structure.

They have a common function of flying but their origins are not common. So, birds and bats are not closely related.

(iii) Fossils and their study is useful in knowing about the species which are no longer alive. They provide evidence and missing links between two classes. They are helpful in forming a sequence of organisms in the pathway of evolution. Thus, fossils have an importance in deciding evolutionary relationship. Archaeopteryx is a fossil bird. It had feathers, fused bones and beak which are exclusively bird structures. It also had some features which are found in reptiles, e.g. teeth in jaw, claws on free fingers and a long tail. This fossil provides a clue that birds have evolved from reptiles.

17. Give an example of body characteristics used to determine how close two species are in terms of evolution and explain it.

Answer. Homologous organs help to identify the relationship between organisms. These characteristics in different organisms would be similar because they have inherited from a common ancestor. For example, forelimbs of human and wings of birds show closeness between the two species because the organs have similar basic structural design of limbs though it has been modified to perform different functions.

18. What are homologous organs? Can the wing of a butterfly and the wing of a bat be regarded as homologous? Why?

Answer. Homologous organs are those organs which have the same basic structural design and developmental origin but have different functions and appearance.

Example: The forelimb of a frog, a lizard, a bird and a man seem to be built from the same basic design of bones, but they perform different functions.

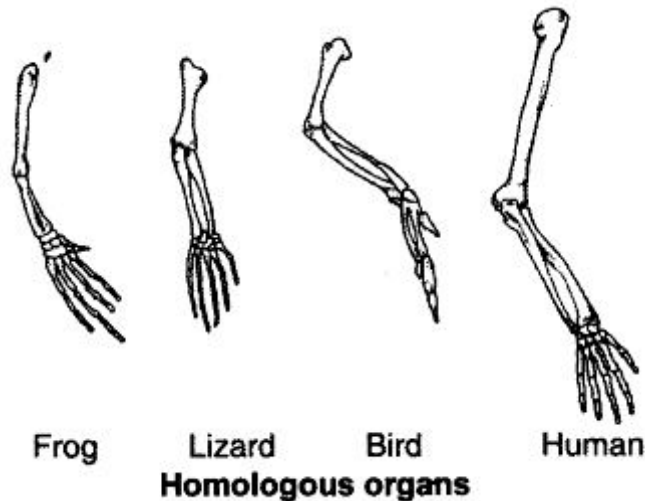

No, the wing of a butterfly and the wing of a bat cannot be considered homologous organs because they have a common function for flying but their origin and structure are not common. So, they are analogous organs.

19. A blue colour flower plant denoted by **BB** is cross bred with that of white colour flower plant denoted by **bb**.

- State the colour of flower you would expect in their F_1 generation plants.
- What must be the percentage of white flower plants in F_2 generation if flowers of F_1 plants are self-pollinated?
- State the expected ratio of the genotypes **BB** and **Bb** in the F_2 progeny. [Delhi]

Answer.

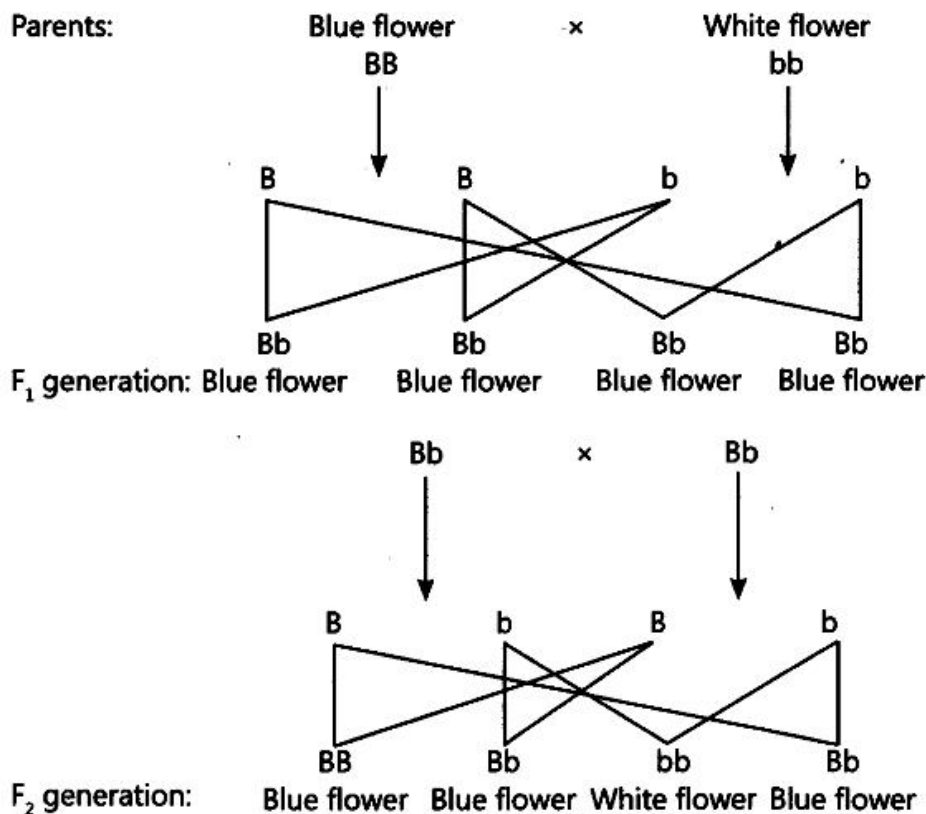

- The colour of all the flowers in F_1 generation will be blue.
- Percentage of white flower plants in F_2 generation will be 25.
- The ratio of genotype **BB** and **Bb** in F_2 progeny will be 1 : 2.

20. **What is meant by the term speciation? List four factors which could lead to speciation.**

Answer. Speciation is the evolution of reproductive isolation among once interbreeding population.

Factors which can lead to speciation are:

Genetic drift: Over generations, genetic drift may accumulate which leads to speciation.

Natural selection: Natural selection may work differently in different location which may give rise to speciation.

Severe DNA change.

A variation may occur which does not allow sexual act between two groups.

21. **Distinguish between homologous organs and analogous organs. In which category ; would you place wings of a bird and wings of a bat? Justify your answer giving a suitable reason.**

Answer.

Homologous organs	Analogous organs
(i) They have same basic structural design.	(i) They have different basic structural designs.
(ii) They perform different functions.	(ii) They perform similar functions.
(iii) Their appearances are different.	(iii) They have similar appearance.

Wings of a bird and wings of a bat are analogous organs as they have different basic structural design but have similar appearance and perform similar functions.

22. **How are fossils formed? Describe, in brief, two methods of determining the age of fossils.**

Answer. When organisms die, their bodies decompose due to action of micro organisms.

However, sometime the body or at least some parts of the body may be in such an environment that does not let it decompose completely. All such preserved traces of living organisms are called fossils.

The age of fossils can be estimated by the following two methods:

If we dig into the earth and start finding fossils, it can be assumed that the fossils closer to the surface are more recent to those found in deeper layers.

By detecting the ratios of different isotopes of the same element in the fossil material.

23. **State the meaning of inherited traits and acquired traits. Which of the two is not passed on to the next generation? Explain with the help of an example.**

Answer. Inherited traits are the characteristics transmitted from parents to their offspring. Acquired traits are characteristics which are developed during the lifetime of an individual. Acquired traits are not passed on to the next generation. For example, if we breed a group of mice, all their progeny will have tails. Now, if the tails of these mice are removed by surgery and allowed to breed, the next generation mice will also have tails. If these tails are also removed and allowed to breed, the progeny of mice will again have tails. Removal of tail by surgery is an acquired trait and do not change the genes of germ cells and hence, are not passed on to the next generation.

24. **“An individual cannot pass on to its progeny the experiences of its lifetime.” Justify the statement with the help of an example and also give reason for the same. [Foreign]**

Answer. Experience achieved during the lifetime of an individual does not make any change in the gene of the individual.

For example, if a person reads a book on birds, the knowledge he earns by reading the book does not make any change in the gene, hence, this knowledge will not get automatically transmitted to his next generation. Such a trait is called acquired trait.

25. **How do Mendel’s experiments show that the (a) traits may be dominant or recessive, (b) traits are inherited independently?**

Answer. Mendel's Experiments on Inheritance of Traits. Mendel used a number of visible contrasting characters of garden pea like round/wrinkled seeds, tall/short plants, white/violet flowers, etc.

Two Visible Contrasting Characters:

- Mendel took pea plants with two different characteristics such as plant with round and green seed and plant with wrinkled and yellow seeds and cross-pollinated then to get F₁ progeny.
- In F₁ progeny, all the plants will have round and yellow seeds. The round and yellow are dominant traits.
- Mendel then allowed F₁ progeny plants for self-pollination to get F₂ progeny.
- F₂ progeny will have plants with round and yellow seeds, round and green seeds, wrinkled and yellow seeds, wrinkled and green seed.
- The ratio of plants with above characteristics will be 9 : 3 : 3 : 1
- Therefore, round seed/wrinkled seed trait are independently inherited.

(a) In F₁ progeny, all the plants will have round and yellow seeds. Wrinkled and green traits were not seen. But wrinkled and green characters appeared in the F₂ progeny.

This means that wrinkle and green characters were recessive trait in F₁ progeny, whereas round and yellow traits were dominant trait.

(b) New mixture of traits are seen in both F₁ and F₂ progeny. This means traits are independently inherited.

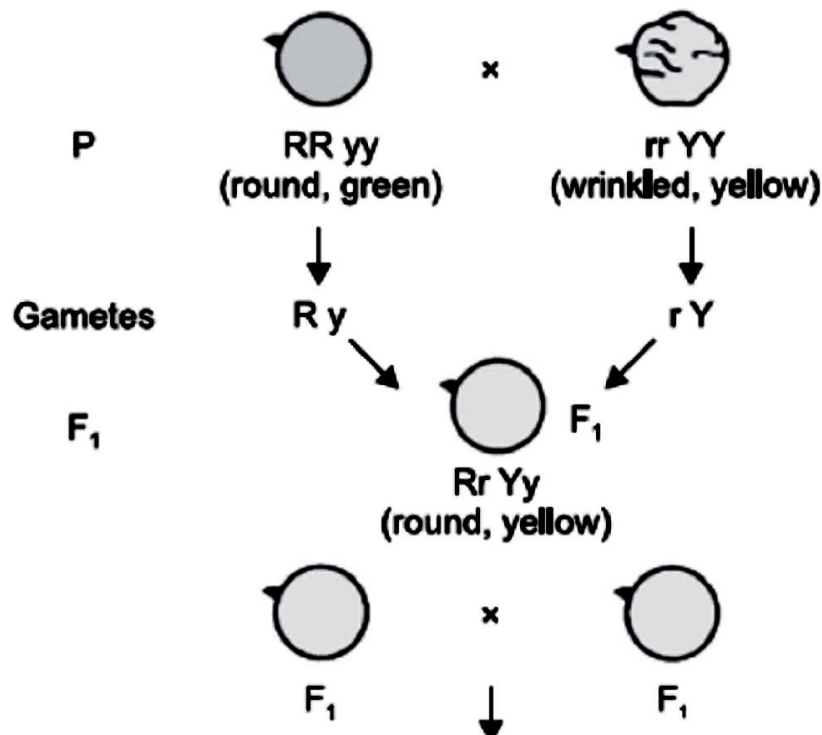

HOW DO ORGANISMS REPRODUCE?

1. (i) **What is fertilisation? Distinguish between external fertilisation and internal fertilisation.**

(ii) **What is the site of fertilisation in human beings?**

Answer.

(i) Fertilisation is defined as the fusion of a male gamete (sperm) with a female gamete (an ovum or egg) to form a zygote during sexual reproduction.

External Fertilisation	Internal Fertilisation
(i) The fusion of male gamete (sperm) and female gamete (ovum) occurs outside the body.	(i) The fusion of gametes occurs inside the body.
(ii) Both individuals discharge their gametes outside the body.	(ii) Only the male discharges sperms into female genital tract.
(iii) Development occurs outside the body.	(iii) Development occurs inside the body.
(iv) Example: Frog.	(iv) Examples: Human, birds, cattle, etc.

(ii) The site of fertilisation in human beings is in the fallopian tube of female reproductive system.

2. **Define the terms unisexual and bisexual giving one example of each.**

Answer. Unisexual is the plant whose flowers contain either stamens or carpels but not both.

Example: Papaya, Watermelon.

Bisexual is the plant whose flowers contain both stamens and carpels. Example: Hibiscus, Mustard.

3. **Differentiate between ‘self-pollination’ and ‘cross-pollination’. Describe double fertilisation in plants.**

Answer.

Self-pollination	Cross-pollination
(i) Self-pollination occurs within a flower or between two flowers of the same plant.	(i) Cross-pollination occurs between two flowers borne on different plants of the same species.
(ii) Flowers do not depend on other agencies for pollination.	(ii) Agents such as insects, water and wind are required for pollination.
(iii) Pollen grains are produced in small numbers.	(iii) Pollen grains are produced in large numbers.

During fertilisation in plants, the following events take place:

(i) One of the male gamete fuses with the female gamete present in the embryo sac.

(ii) The other male gamete fuses with the two polar nuclei in the embryo sac.

The first fusion product gives rise to the zygote while the second one forms the endosperm.

The process of two fusions occurring in the embryo sac is called double fertilisation.

4. **What is the effect of DNA copying which is not perfectly accurate on the reproduction process?**

Answer. DNA copying is not perfectly accurate and the resultant errors are a source of variations in populations of organisms.

5. **What is ‘reproduction’? Mention the importance of DNA copying in reproduction.**

Answer. Reproduction is the process of producing new individuals of the same species by existing organisms of a species, i.e. parents. The importance of DNA copying in reproduction are as follows:

(i) DNA copying is called DNA replication. In this process, one copy each of replicated DNA will

be passed to daughter cells.

(ii) Variations may be introduced during DNA copying. This inbuilt tendency for variation during reproduction forms the basis of evolution.

6. **Name one sexually transmitted disease each caused due to bacterial infection and viral infection. How can these be prevented?**

Answer. Sexually transmitted disease caused due to

(i) Bacterial infection is gonorrhoea, and

(ii) Viral infection is AIDS (Acquired Immune Deficiency Syndrome). These diseases can be prevented by responsible sexual behaviour such as use of condom during intercourse, etc.

7. (a) **In the human body what is the role of (i) seminal vesicles, and (ii) prostate gland?**

(b) **List two functions performed by testis in human beings.**

Answer. (a) The role of seminal vesicles and the prostate gland are as follows:

(i) Seminal vesicles produce seminal plasma which is in the form of fluid makes the transport of sperms smooth.

(ii) Prostate gland secretes prostatic fluid that keeps the sperms alive and helps them to swim vigorously.

(b) Two functions performed by testis in human beings are as follows:

(i) Formation of sperms takes place in testis.

(ii) They secrete the hormone testosterone which regulates the formation of sperms and brings changes in appearance of boys at the time of puberty.

8. **Illustrate the following with the help of suitable diagrams:**

(i) **Binary Fission in Amoeba.**

(ii) **Leaf of Bryophyllum with buds.**

Answer.

(i) **Binary Fission in Amoeba**

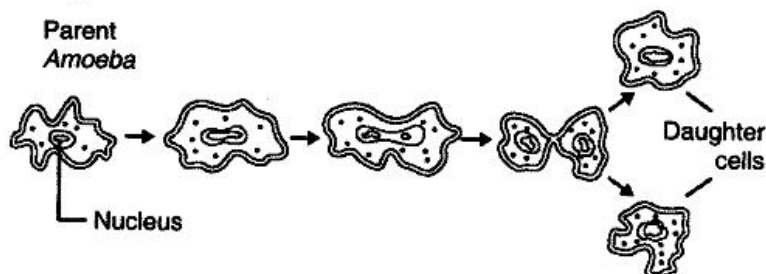

(ii) **Leaf of Bryophyllum with Buds**

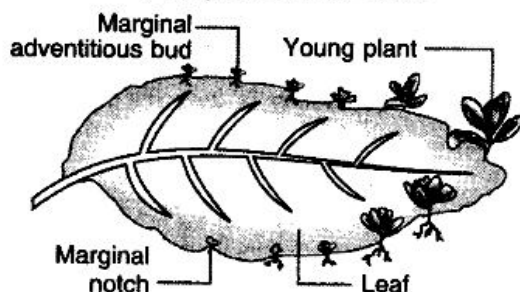

9. **Illustrate the following with the help of suitable diagrams:**

(i) **Spore formation in Rhizopus.**

(ii) **Multiple fission in Plasmodium.**

Answer.

(i) Spore formation in *Rhizopus*

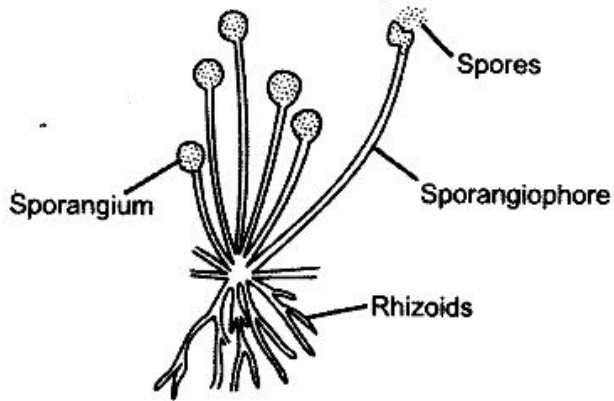

(ii) Multiple fission in *Plasmodium*

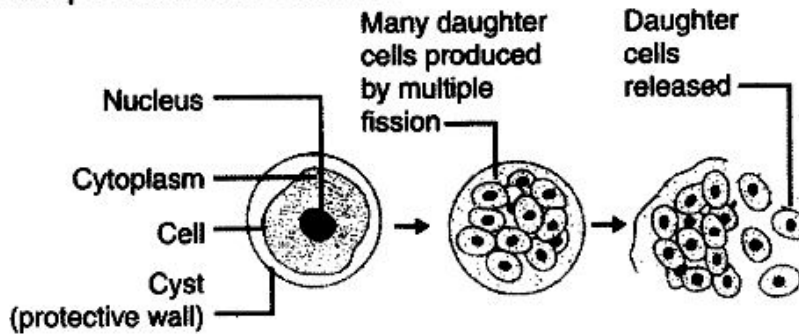

10. (a) Name the parts labelled A, B, C, D and E.

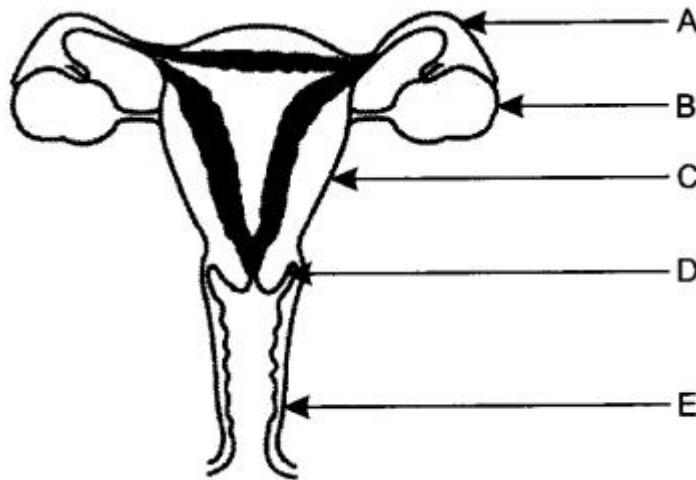

(b) Where do the following functions occur?

(i) Production of an egg

(ii) Fertilisation

(iii) Implantation of zygote.

(c) What happens to the lining of uterus:

(i) before release of a fertilised egg?

(ii) if no fertilisation occurs?

Answer. (a)

A – Oviduct or Fallopian tube;

B – Ovary;

C – Uterus;

D – Cervix;

E – Vagina.

(b) (i) Ovaries; (ii) Fallopian tube;

(iii) Lining of the uterus.

(c) (i) The lining of uterus becomes

(ii) The lining of uterus slowly breaks and comes out through the vagina as blood and mucous, if no fertilisation occurs.

11. (a) **Draw a diagram showing**

germination of pollen on stigma of a flower.

(b) **Label pollen grain, male germ-cells, pollen tube and female germ-cell in the above diagram.**

(c) **How is zygote formed?**

Answer. (a) and (b)

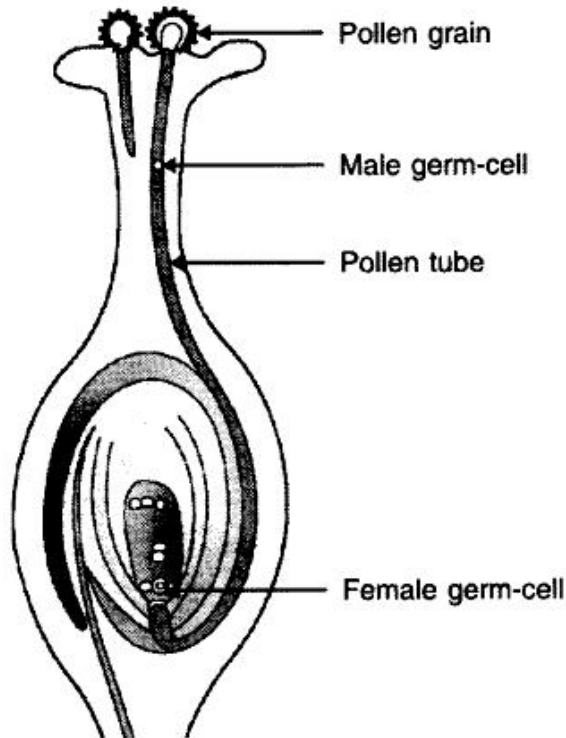

(c) Zygote is formed when male gamete, i.e. sperm fuses with female gamete, i.e. ovum.

12. **Mention the mode of reproduction used by (a) Amoeba (b) Planaria.**

Answer. Mode of reproduction used by

(a) Amoeba is Binary fission.

(b) Planaria is Regeneration.

13. **Name the information source of making proteins in the cell. State two basic events in reproduction.**

Answer. The DNA in the cell nucleus is the information source of making proteins.

The two basic events in reproduction are:

(i) Creation of a DNA copy,

(ii) Additional cellular apparatus by the cell involved in the process.

14. **What is regeneration? State a reason why a more complex organism cannot give rise to new individuals through this method.**

Answer. Regeneration is the ability of a fully differentiated organism to give rise to new individual organisms from its body parts. More complex organisms cannot give rise to new individuals through regeneration because:

(i) their body is highly complicated.

(ii) there are specific organs to do specific functions.

(iii) there is a labour division in the body of complex organisms.

(iv) regeneration is carried out by specialised cells which are not present in complex organisms.

15. **What is reproduction? What are its two types? Which one of the two confers new characteristics on the offsprings and how?**

Answer. Reproduction is the process of producing new individuals of the same species by existing organisms of a species, z.e. parents. Its two types are: Asexual reproduction and Sexual reproduction.

Sexual reproduction confers new characteristics on the offspring due to variation in DNA copying.

16. (a) **Explain the terms: (i) Implantation (ii) Placenta**

(b) **What is the average duration of human pregnancy?**

Answer. (a) (i) Implantation: The embedding of a fertilised mammalian egg (embryo) into the inner thick wall of the uterus (womb) where it will continue its development is called implantation.

(ii) Placenta: It is a complex double-layered spongy vascular tissue in human female formed by the joint activity of maternal and foetal tissues in the wall of uterus that is meant for attachment, nourishment and waste disposal for the foetus.

(b) The average duration of human pregnancy is 40 weeks or 280 days.

17. **What are sexually transmitted diseases? Name four such diseases. Which one of them damages the immune system of human body?**

Answer. Sexually Transmitted Diseases (STDs) are the diseases which are spread by sexual contact from an infected person to a healthy person. They are caused by various microorganisms that live in warm and moist environments of the vagina, urethra, anus and mouth.

The four sexually transmitted diseases are:

(i) Gonorrhoea

(ii) Syphilis

(iii) Trichomoniasis

(iv) AIDS (Acquired Immune Deficiency Syndrome).

AIDS damages the immune system of human body.

18. **List any four reasons for vegetative propagation being practised in the growth of some type of plants.**

Answer.

(i) Vegetative propagation is a cheaper, easier and more rapid method of propagation in plants than growing plants from their seeds.

(ii) Better quality of plants can be maintained by this method.

(iii) It results in propagation of those plants which do not produce viable seeds or produce seeds with prolonged period of dormancy.

(iv) The plants generated from vegetative means are more uniform and genetically similar to the parent stock.

19. **Write the full form of DNA. Name the part of the cell where it is located. Explain its role in the process of reproduction of the cell.**

Answer. The full form of DNA is deoxyribonucleic acid. It is the genetic material found in the chromosomes, which are present in the nucleus of a cell.

Role of DNA in the process of reproduction of the cell:

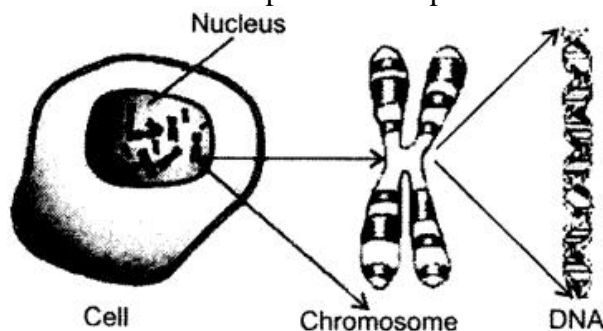

DNA plays an important role in the reproduction of a cell. The reproducing cell produces an identical copy of DNA through some cellular mechanism. Since the newly formed copy of DNA lacks an organised cellular structure, the cell gets divided to provide cell cover to the newly

formed DNA. Thus, two daughter cells are formed from the single cell as a result of the copying of DNA.

20. **List any three differences between pollination and fertilisation.**

Answer.

Pollination	Fertilisation
(i) It is the transfer of pollen grains from anther to the stigma of a flower.	(i) It is the fusion of male and female gametes.
(ii) Pollination precedes fertilisation.	(ii) Fertilisation occurs only after pollination when the pollen grain has germinated and sent the male gametes to ovule.
(iii) Pollination carries the male gamete producing pollen grains to the female sex organ.	(iii) Fertilisation brings about fusion of gametes.

21. **Draw a longitudinal section of a flower and label the following parts:**

- (i) Part that produces pollen grain.
- (ii) Part that transfers male gametes to the female gametes.
- (iii) Part that is sticky to trap the pollen grain.
- (iv) Part that develops into a fruit.

Answer.

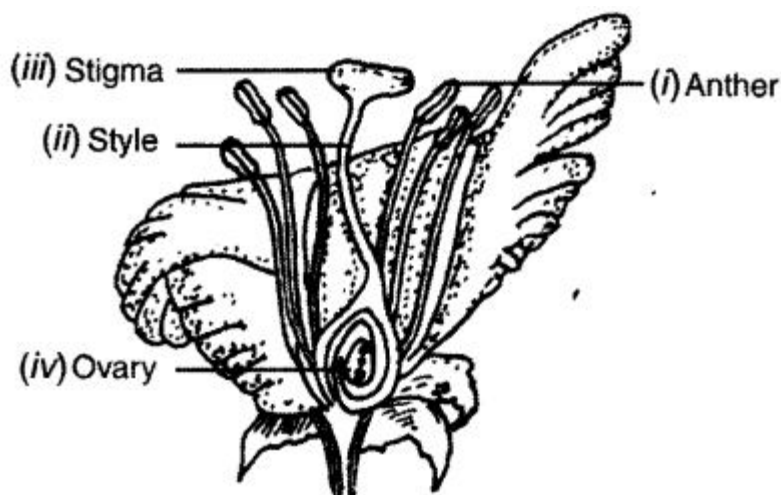

22. **Explain vegetative propagation with the help of two examples. List two advantages of vegetative propagation.**

Answer. In vegetative propagation, new plants are obtained from the parts of old plants like stems, roots and leaves, without the help of any reproductive organ.

There are two ways of vegetative propagation:

- (a) Natural Vegetative Propagation, and
- (b) Artificial Vegetative Propagation.

Natural vegetative propagation by leaves: The fleshy leaves of Bryophyllum bear adventitious buds in the notches along the leaf margin.

Grafting: In this method of reproduction, two plants of closely related varieties are joined together so that they live as one plant.

- The portion of a plant that is grafted on the other plant is called scion, and the plant in which grafting is performed is called the stock.
 - This method is applied to improve variety of fruits like mango, apple, peas, citrus and guava.
- advantages of vegetative propagation are:

(i) Vegetative propagation is a cheaper, easier and more rapid method of propagation in plants than growing plants from their seeds.

(ii) Better quality of the plants can be maintained by this method.

23. (a) **Explain the role of placenta in the development of human embryo.**

(b) **Give example of two bacterial and two viral sexually transmitted diseases. Name the most effective contraceptive which prevents spread of such diseases.**

Answer.

(a) Role of placenta in the development of human embryo: A special tissue develops between the uterine wall and the embryo (foetus) called placenta, where exchange of nutrients, glucose and oxygen takes place. The developing embryo will also generate waste substances which can be removed by transferring them into the mother's blood through the placenta. The development of the child inside the mother's blood takes approximately nine months.

(b) Sexually transmitted diseases (STDs) transmitted by bacteria are:

(i) Gonorrhoea (ii) Syphilis

STDs transmitted by virus:

(i) AIDS (ii) Genital warts

The most effective contraceptive which prevents the spread of these diseases is by the use of mechanical barriers such as physical devices like condoms.

24. **Write any two differences between binary fission and multiple fission in a tabular form as observed in cells of organisms.**

Answer.

Binary fission	Multiple fission
(i) It is the division of the parent into two nearly equal sized daughter individuals	(i) It is the division of the parent into many small daughter individuals
(ii) Two daughter individuals are formed by a simple division or splitting.	(ii) Nucleus of the parent cell divides to form a number of nuclei.

25. **List any four modes of asexual reproduction.**

Answer. Four modes of asexual reproduction are—Binary fission in Amoeba, Fragmentation in Spirogyra, Regeneration in Planaria and Budding in Hydra.

26. **Why is DNA copying an essential part of the process of reproduction?**

Answer. DNA copying is an essential part of the process of reproduction because:

(i) DNA copying provides cellular apparatus in the daughter cells.

(ii) DNA in daughter cells will be able to control the functioning of daughter cells.

(iii) DNA copies will retain the traits.

27. **What does HIV stand for? Is AIDS an infectious disease? List any four modes of spreading AIDS.**

Answer. HIV stands for Human Immunodeficiency Virus.

Yes, AIDS is an infectious disease.

Four modes of spreading AIDS are as follows:

(i) By having sexual contact with an infected person.

(ii) By the transfusion of blood from an infected person.

(iii) Through infected needles used for injection.

(iv) Through the placenta from the mother to child during pregnancy.

28. **Expand AIDS. List any four methods of prevention (control) of AIDS.**

Answer. AIDS stands for Acquired Immune Deficiency Syndrome.

Four methods of prevention or control of AIDS are as follows:

(i) Use condom during sex.

(ii) Avoid sharing of needles.

(iii) Test blood for AIDS before transfusion.

(iv) Avoid sexual contact with unknown person.

29. (a) What is fragmentation in organism?

Name a multicellular organism which reproduces by this method.

(b) What is regeneration in organism? Describe regeneration in Planaria with the help of a suitable diagram.

Answer. (a) Fragmentation: Multicellular organisms with simple body organisation such as filamentous algae-Spirogyra breaks up into two or more small pieces or fragments upon maturation. These fragments grow into new individuals.

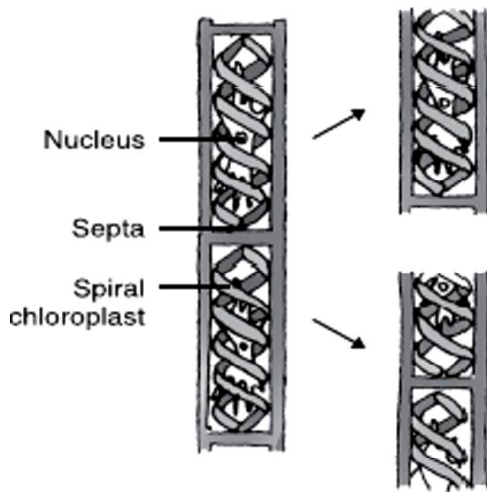

Fragmentation in Spirogyra

(b) Regeneration: It is the ability of a fully differentiated organism to give rise to new individual organisms from its body parts.

- Small cut or broken parts of the organism body grow or regenerate into separate individuals.
- Planaria can be cut into any number of pieces and each piece grows into a complete organism.
- Regeneration is carried out by specialised cells which proliferate and make large number of cells thus, undergoing changes to become various cell types and tissues.
- The changes taking place in an organised sequence is development.

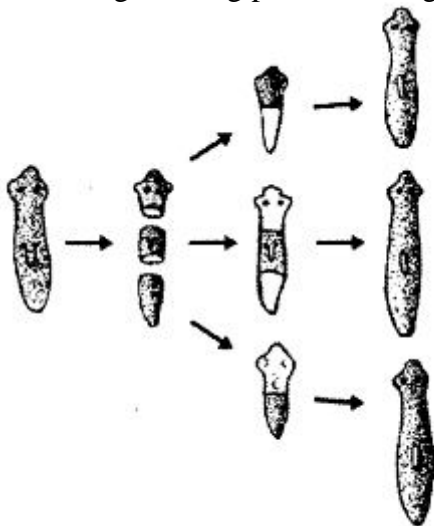

Regeneration in Planaria

30. With the help of suitable diagrams, explain the various steps of budding in Hydra.

Answer.

- Hydra reproduces by budding using the regenerative cells.
- A bud develops as an outgrowth in Hydra due to repeated cell division at one specific site.

- When fully matures, the bud detaches itself from the parent body and develops into new independent individuals

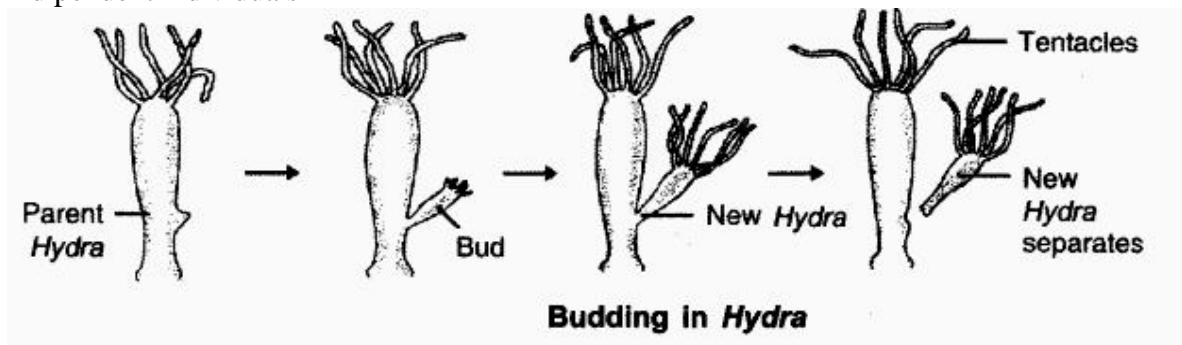

31. (a) What is spore formation?
 (b) Draw a diagram showing spore formation in Rhizopus.
 (c) List two advantages for organisms to reproduce themselves through spores.

Answer.

- (a) When a slice of bread is kept in moist dark place for a few days, spores of Rhizopus present in air settle on the bread to form new fungus plants of Rhizopus.
 (b) The Rhizopus consists of fine thread-like projections called hyphae. It has a knob like structure which is involved in reproduction called sporangia, containing spores, that develop into new Rhizopus.

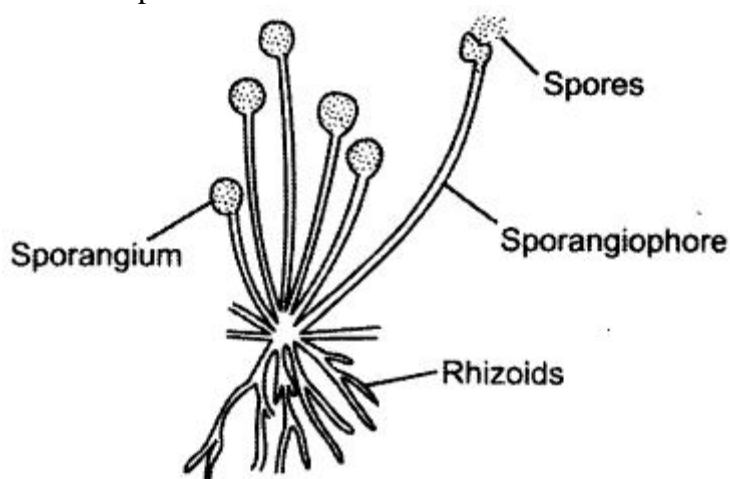

Spore formation in Rhizopus

- (c) Two advantages for organisms to reproduce themselves through spores are as follows:
 (i) It is a faster mode of reproduction.
 (ii) Offsprings produced are identical.
32. State one genetically different feature between sperms and eggs of humans. What is its consequence?

Answer. The sex chromosome of human male is XY. A sperm of human male carries either an X chromosome or one Y chromosome.

The sex chromosome of human female is XX and hence, the egg always carries the X chromosome.

If a sperm carrying X chromosome fertilises an egg which carries X chromosome, then the child born will be a girl. If a sperm carrying Y chromosome fertilises an egg which carries X chromosome, then the child born will be a boy.

33. Define the term puberty. List two changes observed in girls at the time of puberty.

Answer. The period, when the rate of general body growth begins to slow down and reproductive tissues begin to mature, is called puberty.

Two changes observed in girls at the time of puberty are:

(i) The breast size begin to increase, (ii) Menstruation starts.

34. **What is meant by asexual reproduction? List its any two different forms.**

Answer. Asexual reproduction is the process of producing new organism from a single parent without the involvement of sex cells. Fission and fragmentation are two different forms of asexual reproduction.

35. **Name an organism which reproduces by spore formation. List three conditions favourable for spores to germinate and grow.**

Answer. Rhizopus reproduces by spore formation. Conditions favourable for spore formation are:

(i) Cool place, (ii) Moist place and (iii) Dark place.

36. **“DNA copies generated during reproduction will be similar but may not be identical to the original.” Justify this statement.**

Answer. DNA copies generated will be similar, but may not be identical to the original as some variations are so drastic that new DNA copy cannot work with the cellular apparatus it inherits. Such a newborn cell will simply die. Therefore, there could be many other variations in the DNA copies that would not lead to such a drastic outcome. Thus, the surviving cells are similar but slightly different from each other. This tendency of variation during reproduction is the basis for evolution.

37. **List the parts of human male reproductive system which contribute fluid to the semen. State two advantages semen offers to the sperms.**

Answer. Prostate glands and seminal vesicles add fluid in the vas deferens. This makes transportation of sperms easier and also provides nutrition to the sperms.

38. **Name the two types of germ-cells present in human beings. How do they structurally differ from each other? Give two differences.**

Answer. The two types of germ-cells present in human beings are sperm and ova. The sperm of human have either X or Y chromosome. The ova always carry X chromosome. The sperm is structurally long with a tail. The ova is round in structure.

39. **List and explain in brief three methods of contraception.**

Answer. Methods of contraception are:

Use of condom for penis or for vagina as a mechanical barrier for the sperms to reach the egg.

Use of oral pills which change the hormonal balance so that eggs are not released.

Surgical method where either the vas deferens of male is blocked or the fallopian tube of female is blocked.

40. **What is AIDS? Which microbe is responsible for AIDS infection? State one mode of transmission of this disease. Explain in brief one measure for the prevention of AIDS.**

Answer. AIDS is the Acquired Immune Deficiency Syndrome.

It is caused by a virus called Human Immunodeficiency Virus.

AIDS is transmitted by sexual contact with an infected person.

AIDS can be prevented by avoiding sexual contact with infected person or by using condom during sex.

41. **Describe in brief the role of (i) testis (ii) seminal vesicle, (iii) vas deferens, (iv) ureter and (v) prostate gland in human male reproductive system.**

Answer.

Testis: Testes are oval shaped primary reproductive organs in men. The function of testes is to produce sperms and male sex hormone testosterone. The scrotum provides optimal temperature for the formation of sperms.

Seminal vesicle: Seminal vesicles are a pair of thin walled muscular elongated sac which secrete fluid for nourishment of sperms.

vas deferens: The sperms are carried by a long tube called vas deferens to organs called seminal vesicles where the sperms get nourishment and stored.

Ureter It is the tube that carries urine from kidney to the urinary bladder. In humans, there are two ureters, one attached to each kidney.

Prostate glands: Prostate glands produce a fluid which is released in the urethra along with secretion of seminal vesicles for nourishment and transportation of sperms.

42. **Draw a diagram of a human female reproductive system and label the part**
(i) that produces egg
(ii) where fusion of egg and sperm take place
(iii) where zygote is implanted

What happens to human egg when it is not fertilised?

Answer.

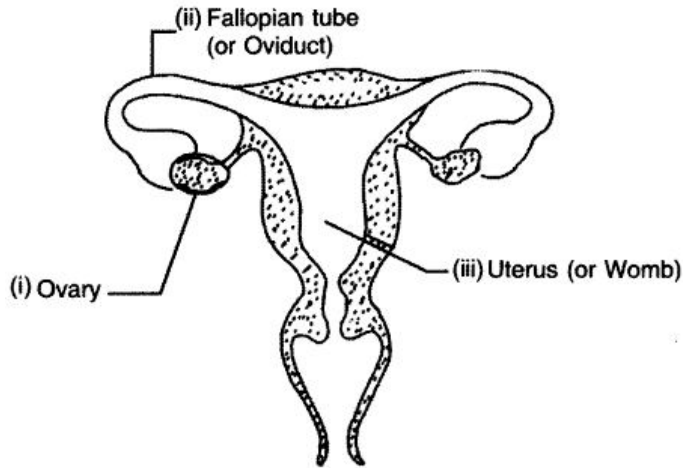

Human Female Reproductive System

If the egg is not fertilised, the thick and nourishing lining of the uterus breaks and comes out through vagina as blood and mucous.

43. **State in brief the changes that take place in a fertilised egg (zygote) till birth of the child in the human female reproductive system. What happens to the egg when it is not fertilised?**

Answer. The egg gets fertilised in the oviduct. The fertilised egg, the zygote gets implanted in the lining of the uterus and starts dividing. The uterus prepares itself every month to receive and nurture the growing embryo. The lining thickens and is richly supplied with blood to nourish the growing embryo.

The embryo gets nutrition from the mother's blood with the help of a special tissue called placenta. The development of the child inside the mother's body takes approximately nine months. On completion of 9 months, the child is born as a result of rhythmic contractions of the muscles in the uterus.

If the egg is not fertilised, the thick and nourishing lining of the uterus breaks and comes out through vagina as blood and mucous.

ACIDS BASES AND SALTS

1. **The pH of a sample of vegetable soup was found to be 6.5. How is this soup likely to taste?**

Answer. The taste will be slightly sour as it is weakly acidic.

2. **Which bases are called alkalies? Give an example of alkalies.**

Answer. Soluble bases are called alkalies, e.g. sodium hydroxide (NaOH).

3. **Write a balanced chemical equation for the reaction between sodium carbonate and hydrochloric acid indicating the physical state of the reactants and the products.**

Answer.

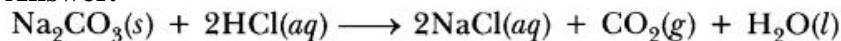

4. **Write a balanced chemical equation for a neutralisation reaction, mentioning the physical state of the reactants and the products.**

Answer.

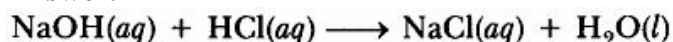

5. **What happens when chlorine is passed over slaked lime at 313K? Write chemical equation of the reaction involved and state two uses of the product obtained.**

Answer. Bleaching powder is formed.

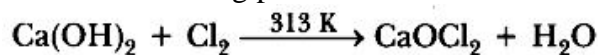

(i) It is used as bleaching agent in paper and textile industries.

(ii) It is used as disinfectant in purification of drinking water.

6. **What would be the colour of red litmus in a solution of sodium carbonate?**

Answer. The red litmus will change to blue in sodium carbonate solution.

7. **Which gas is evolved when sodium hydrogencarbonate reacts with dilute hydrochloric acid?**

Answer. Carbon dioxide gas is evolved.

8. **Curd is not kept in copper and brass utensils. Why?**

Answer. Curd and sour substances contain acids which react with brass and copper vessels to form poisonous salts which are harmful for our health.

9. **Name the gas usually liberated when a dilute acid reacts with a metal. What happens when a burning candle is brought near this gas?**

Answer. H₂ gas is liberated. It burns with pop sound when burning candle is brought near the gas.

10. **What effect does an increase in concentration of H⁺(aq.) in a solution have on the pH of solution?**

Answer. Higher the concentration, lower will be pH of the solution.

11. **Which one of these has a higher concentration of H⁺ ions? 1 M HCl or 1 M CH₃COOH**

Answer. 1 M HCl has higher concentration of H⁺ ions.

12. **Why does 1 M HCl solution have a higher concentration of H⁺ ions than 1 M CH₃COOH solution?**

Answer. 1 M HCl has higher conc. of (H⁺) because it ionises completely in aqueous solution whereas CH₃COOH does not as it is weak acid.

13. **Which gas is generally liberated when a dilute solution of hydrochloric acid reacts with an active metal?**

Answer. Hydrogen gas is liberated when active metal reacts with dilute hydrochloric acid



14. **What is the colour of litmus in a solution of ammonium hydroxide?**

Answer. Red litmus will turn blue in ammonium hydroxide.

15. **Name the natural source of each of the following acid**

(i) Citric acid. (ii) Oxalic acid.

(iii) Lactic acid. (iv) Tartaric acid.

Answer. (i) Lemon and orange. (ii) Tomatoes and Guava.

(iii) Sour milk (curd). (iv) Tamarind.

16. A student detected the pH of four unknown solution A, B, C and D as follows 11, 5, 7 and 2. Predict the nature of the solution.

Answer. A is basic 'B' is acidic 'C' is natural and 'D' is strongly acidic.

17. (i) Give the constituents of baking powder
(ii) Why cake or bread swells on adding baking powder? Write chemical equation.

Answer.

(i) Baking powder containing sodium hydrogen carbonate and tartaric acid.

(ii) It is due to carbon dioxide

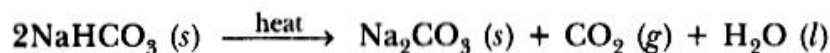

18. How will you test for the gas which is liberated when hydrochloric acid reacts with an active metal?

Answer. Bring a burning matchstick near the gas. It burns with 'pop' sound showing that it is hydrogen.

19. Name the acid present in the following:

(i) Tomato (ii) Vinegar (iii) Tamarind

Answer. (i) Oxalic acid (ii) Acetic acid (iii) Tartaric acid

20. Explain how antacid works.

Answer. Hyperacidity is caused by excess of hydrochloric acid in stomach. Antacid is basic in nature. It neutralizes excess of acid and gives relief from pain caused by hyperacidity.

21. (a) Define olfactory indicators. Name two substances which can be used as olfactory indicator.

(b) Choose strong acids from the following:

CH_3COOH , H_2SO_4 , H_2CO_3 , HNO_3

Answer.

(a) Those substances whose smell (odour) changes in acidic or basic solution are called olfactory indicators, e.g. onion and vanilla.

(b) H_2SO_4 and HNO_3 are strong acids.

22. A white coloured powder is used by doctors for supporting fractured bones.

(a) Write chemical name and formula of the powder.

(b) When this white powder is mixed with water a hard solid mass is obtained. Write balanced chemical equation for the change.

Answer.

(a) Calcium sulphate hemihydrate

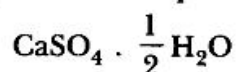

(b) $\text{CaSO}_4 \cdot \frac{1}{2} \text{H}_2\text{O} + \frac{3}{2} \text{H}_2\text{O} \longrightarrow \text{CaSO}_4 \cdot 2\text{H}_2\text{O}$

23. Explain the action of dilute hydrochloric acid on the following with chemical equation:

(i) Magnesium ribbon (ii) Sodium hydroxide (iii) Crushed egg shells

Answer.

(i) Hydrogen gas will be formed



(ii) Sodium chloride and water will be formed

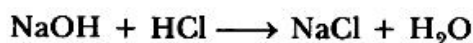

(iii) Crushed egg shells are made up of CaCO_3 which reacts with dil HCl to give brisk effervescence due to CO_2

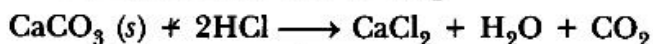

24. State reason for the following statements:

(i) Tap water conducts electricity whereas distilled water does not.

(ii) Dry hydrogen chloride gas does not turn blue litmus red whereas dilute hydrochloric

acid does.

(iii) During summer season, a milk man usually adds a very small amount of baking soda to fresh milk.

(iv) For a dilution of acid, acid is added into water and not water into acid.

(v) Ammonia is a base but does not contain hydroxyl group.

Answer.

(i) Tap water contains ions which conduct electricity, distilled water does not contain ions.

(ii) Dry HCl does not form ions but HCl gives H^+ and Cl^- .

(iii) Baking soda does not allow milk to change to lactic acid which makes milk sour.

(iv) Adding water to acid is highly exothermic. Therefore water is added to acid very slowly with cooling.

(v) Ammonia dissolves in water and forms H^- Therefore, it is basic in nature.

25. (a) Write the chemical formula of hydrated copper sulphate and anhydrous copper sulphate. Giving an activity illustrate how these are inter convertible.

(b) Write chemical names and formula of plaster of paris and gypsum.

Answer.

(a) $CuSO_4 \cdot 5H_2O$ is hydrated copper sulphate. $CuSO_4$ is anhydrous copper sulphate.

Aim: To show crystalline salts contain water of crystallization.

Material Required: $CuSO_4 \cdot 5H_2O$ (Blue vitriol), boiling tube, burner, cork, delivery tube, test tube, clamp stand.

Procedure: 1. Take 2g of $CuSO_4 \cdot 5H_2O$ in a boiling tube fitted in a clamp stand.

2. Observe its colour. Fit it with cork and delivery tube bent at two right angles which dips into a test tube.

3. Heat crystals in boiling tube.

4. Observe vapours being condensed in test tube.

5. Cool the crystals and add few drops of water into it.

Observation: Water vapours get condensed in a test tube and colour

of blue crystals changes into white. On adding water to anhydrous copper sulphate it changes into blue again.

Chemical Reaction :

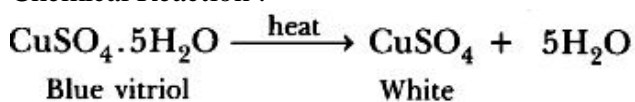

Conclusion : Crystalline substances have water of crystallization which are lost on heating. When we add water in $CuSO_4$ till a saturated solution is formed. On cooling, it gets converted into $CuSO_4 \cdot 5H_2O$ crystals and it shows that both are inter convertible.

$CaSO_4 \cdot \frac{1}{2} H_2O$ calcium sulphate hemihydrate

$CaSO_4 \cdot 2H_2O$ calcium sulphate dihydrate.

26. (a) Write the name given to bases that are highly soluble in water. Give an example.

(b) How is tooth decay related to pH? How can it be prevented?

(c) Why does bee sting cause pain and irritation? Rubbing of baking soda on the sting area gives relief. How?

Answer.(a) Alkali, e.g. NaOH (Sodium hydroxide).

(b) Lower the pH, more will be tooth decay. Acid reacts with $Ca_3(PO_4)_2$ and cause tooth decay. It can be prevented by brushing teeth after every meal.

(c) It is due to formic acid. Sodium hydrogencarbonate (Baking soda) neutralises formic acid giving relief.

27. (a) State the chemical properties on which the following uses of baking soda are based:

(i) as an antacid

(ii) as a soda acid fire extinguisher

(iii) to make bread and cake soft and spongy.

Answer.

(b) How is washing soda is obtained from baking soda? Write balanced chemical equation.

(a) (i) It is weakly basic in nature and naturalize hyperacidity.

(ii) It liberates CO_2 with H_2SO_4 , which extinguish fire.

(iii) It liberates CO_2 on heating which makes bread and cake soft and sponge.

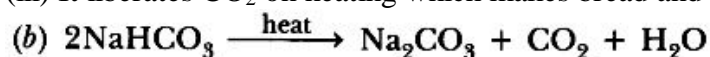

Baking soda on heating gives sodium carbonate which on crystallisation from hydrated washing soda



28. Describe an activity with diagram to illustrate that the reaction of metal carbonates and metal bicarbonates with acids produces carbon dioxide. Write the relevant equations of all the reactions that take place. Name any two forms in which calcium carbonate is found in nature.

Answer.

Aim: To show acid reacts with metal carbonate to liberate carbon dioxide,

Material Required: CaCO_3 (marble chips), Woulfe-bottle, thistle funnel, dil. HCl, gas jar, matchbox, delivery tube bent at two right angles, lime water.

Procedure:

Take two test tubes, label them as A and B.

Take about 0.5 g of sodium carbonate (Na_2CO_3) in test tube A and about 0.5 g of sodium hydrogen carbonate (NaHCO_3) in test tube B.

Add about 2 mL of dilute HCl to both the test tubes.

Pass the gas produced in each case through lime water (calcium hydroxide solution) as shown in below figure and record your observations.

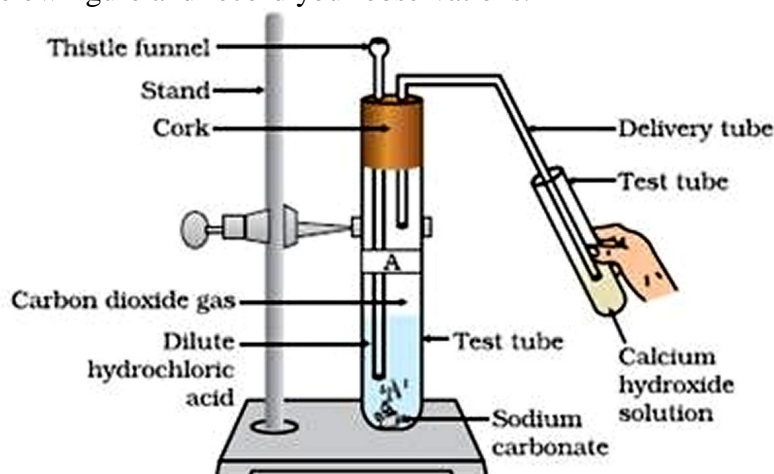

The reactions occurring in the above Activity are written as

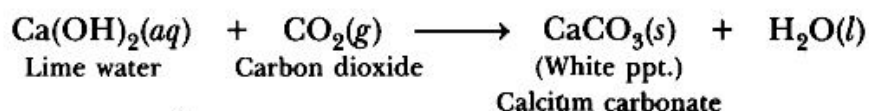
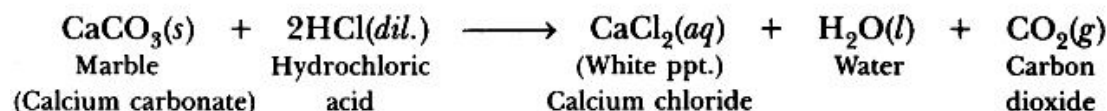

Conclusion: Metal carbonates react with dilute acids to liberate carbon dioxide. Limestone, chalk, marble are different forms of calcium carbonate. All metal carbonates and hydrogen carbonates react with acids to form corresponding salts, water and carbon dioxide.

29. “Sodium hydrogencarbonate is a basic salt”. Justify the statement. How is it converted into washing soda? Explain.

Answer. Sodium hydrogen carbonate is a salt of sodium hydroxide (strong base) and carbonic acid (weak acid).

It is basic salt. It is converted into washing soda by heating followed by crystallization.

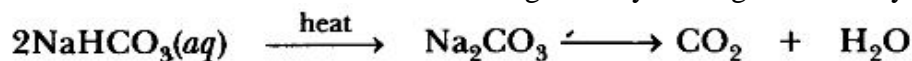

30. (a) Identify the acid and the base whose combination forms the common salt that you use in your food. Write its formula and chemical name of this salt. Name the source from where it is obtained.

(b) What is rock salt? Mention its colour and the reason due to which it has this colour.

(c) What happens when electricity is passed through brine? Write the chemical equation for it.

Answer.

(a) HCl is acid and NaOH is base whose combination forms the common salt. Its formula is NaCl (Sodium chloride). It is obtained from sea water.

(b) Rock salt is the common name for the mineral "halite". Its chemical formula is NaCl. It may be white or light blue or yellow depending upon impurities present in it.

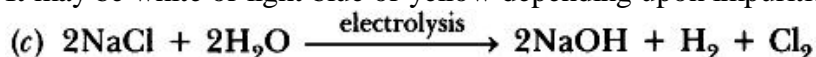

31. (i) Explain why is hydrochloric acid a strong acid and acetic acid, a weak acid. How can it be verified?

(ii) Explain why aqueous solution of an acid conducts electricity.

(iii) You have four solutions A, B, C and D. The pH of solution A is 6, B is 9, C is 12 and D is 7,

(a) Identify the most acidic and most basic solutions.

(b) Arrange the above four solutions in the increasing order of H^+ ion concentration.

(c) State the change in colour of pH paper on dipping in solution C and D.

Answer.

(i) HCl is completely ionised in aqueous solution whereas acetic acid is partially ionised in aqueous solution. HCl gives dark red colour with pH paper whereas CH_3COOH gives orange colour

(ii) It is because acid ionises in aqueous solution and these ions conduct electricity. (Hi) (a) 'A' is most acidic and 'C' is most basic.

(b) $\text{C} (10^{-12}) < \text{B} (10^{-9}) < \text{D} (10^{-7}) < \text{A} (10^{-6})$

(c) pH paper will become blue in 'C' and green in 'D'.

32. (a) Identify the compound of calcium which is yellowish white powder and is used for disinfecting drinking water. Write its chemical name and formula. How is it manufactured? Write the chemical equation for the reaction involved. Also list two other uses of the compound.

(b) Write the balanced chemical equation of chlor-alkali process.

Answer. (a) The compound is bleaching powder (CaOCl_2). Its chemical name is calcium oxychloride. It is manufactured by reaction of solid slaked lime with dry chlorine gas.



(i) It is used as disinfectant.

(ii) It is used for preparation of chloroform.

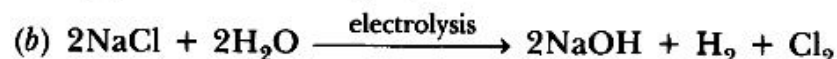

33. (a) Mention the pH range within which our body works. Explain how antacids give relief from acidity. Write the name of one such antacid.

(b) Fresh milk has a pH of 6. How does the pH will change as it turns to curd? Explain your answer.

(c) A milkman adds a very small amount of baking soda to fresh milk. Why does this milk take a longer time to set as curd?

(d) Mention the nature of toothpastes. How do they prevent tooth decay?

Answer.

- (a) Our stomach has pH equal to 2. Antacids neutralizes excess of acid in our body and gives relief from hyperacidity. Sodium hydrogencarbonate is one of such antacid.
- (b) pH will decrease as it turns to curd because curd is acidic due to the presence of lactic acid.
- (c) It takes longer time to set as curd as bacteria do not work well in presence of sodium hydrogencarbonate, i.e. fermentation will take place slowly.
- (d) Toothpastes are basic in nature. They neutralize the acid formed in mouth which causes tooth decay.

34. (a) Crystals of a substance changed their colour on heating in a closed test tube but regained it after sometime when they were allowed to cool down. Name the substance and write its formula and explain the phenomenon involved.
- (b) Name the compound whose one formula unit is associated with 10 water molecules. How is it prepared? Give equations of related reactions. Give two uses of the compound.

Answer.

(a) $\text{CuSO}_4 \cdot 5\text{H}_2\text{O}$ is a blue crystalline solid. It becomes dirty white on heating due to loss of water molecules and it becomes amorphous.

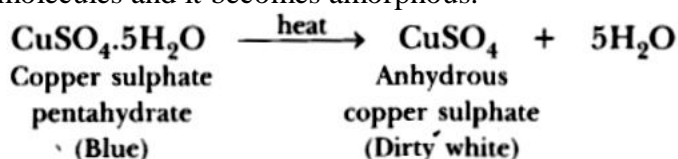

It regains its colour by absorbing water from atmosphere and becomes blue in colour.

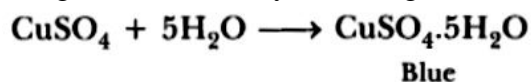

(b) $\text{Na}_2\text{CO}_3 \cdot 10\text{H}_2\text{O}$. It is called sodium carbonate decahydrate or washing soda. It is prepared by passing CO_2 gas through saturated solution of ammonical brine.

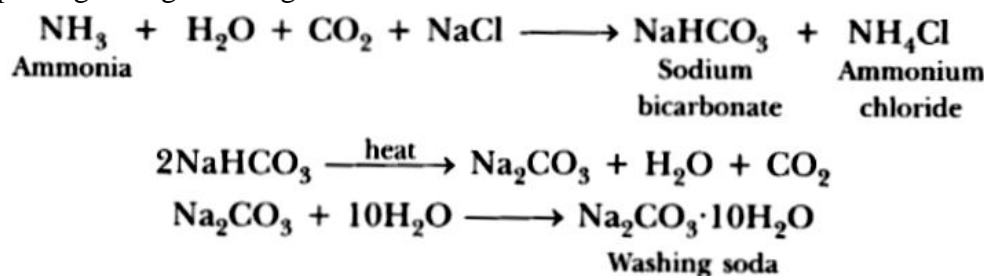

Uses:

- (i) It is used in the production of washing powder.
- (ii) It is used for the manufacture of glass.

35. (a) Explain the following with the help of balanced chemical equations only.

- (i) When an acid reacts with a metal carbonate.
- (ii) When an acid reacts with a metal bicarbonate.
- (iii) When an acid reacts with a metal oxide.

(b) You are given three solutions A, B and C with pH values 2, 10 and 13 respectively. Write which solution has more hydrogen ion concentration among the three and state the nature 'acidic or basic' of each solution.

Answer.

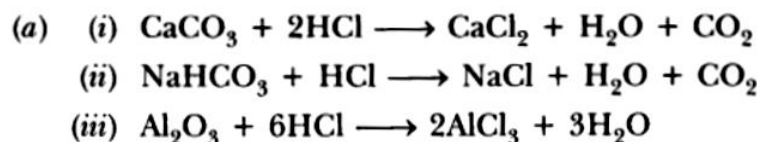

(b) 'A' has maximum $[\text{H}_3\text{O}^+]$ equal $10^{-2} \text{ mol L}^{-1}$

'A' is acidic whereas B and C are basic in nature.

36. a) A metal compound 'X' reacts with dil. H_2SO_4 to produce effervescence, The gas evolved extinguishes a burning candle. If one of the compound formed is calcium sulphate, then what is 'X' and the gas evolved? Also, write a balanced chemical equation for the reaction

which occurred.

(b) (i) Name one antacid. How does it help to relieve indigestion in stomach?

(ii) A farmer treats the soil with quicklime or calcium carbonate. What is the nature of soil? Why does the farmer treat the soil with quicklime?

Answer.

(a) 'X' is CaCO_3 (calcium carbonate). The gas evolved is CO_2 .

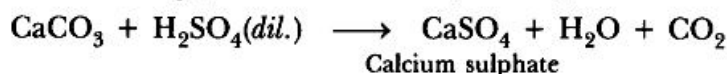

(b) (i) NaHCO_3 is antacid. It neutralizes excess of acid formed in the stomach.

(ii) The soil is acidic in nature. The farmer wants to make it neutral by adding quicklime which is good for crops.

37. What are strong and weak acids? In the following list of acids, separate strong acids from weak acids. Hydrochloric acid, citric acid, acetic acid, nitric acid, formic acid, sulphuric acid.

Answer. Strong acids are those acids which are completely ionised in aqueous solution. Weak acids are those which do not ionise completely in aqueous solution. Strong acid: HCl , HNO_3 , H_2SO_4 Weak acid: Citric acid, acetic acid, formic acid.

38. State the chemical name of Plaster of Paris. Write a chemical equation to show the reaction between Plaster of Paris and water.

Answer. Calcium sulphate hemihydrate.

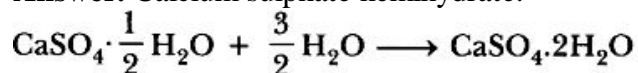

39. State in brief the preparation of washing soda from baking soda. Write balanced chemical equation of the reaction involved.

Answer. Sodium hydrogencarbonate (baking soda) on heating gives sodium carbonate which on recrystallisation gives washing soda.

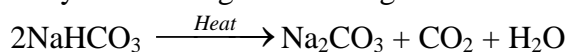

Baking soda on heating gives sodium carbonate which on crystallisation from aqueous solution gives washing soda, e.g.

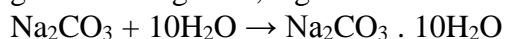

40. What is the colour of $\text{FeSO}_4 \cdot 7\text{H}_2\text{O}$ crystals? How does this colour change upon heating? Give balanced chemical equation for the changes.

Answer. Pale green is the colour of $\text{FeSO}_4 \cdot 7\text{H}_2\text{O}$ crystals. It becomes dirty white on heating.

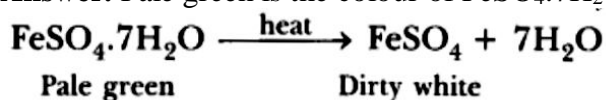

41. Classify the following salts into acidic, basic and neutral: Potassium sulphate, ammonium chloride, sodium carbonate, sodium chloride.

Answer. Neutral: Potassium sulphate, Sodium chloride Acidic: Ammonium chloride Basic: Sodium carbonate

42. State reasons for the following statements:

(i) Stain of curry on a white cloth becomes reddish brown when soap is scrubbed on it and turns yellow again when the cloth is washed with plenty of water.

(ii) Curd should not be kept in copper or brass vessels. What is done to protect it?

Answer. (i) Turmeric reacts with sodium hydroxide present in soap to form red coloured compound. It turns yellow again because sodium hydroxide becomes very dilute on adding lot of water and reaction stops.

(ii) Curd contains lactic acid which reacts with copper or brass vessels and taste changes. Curd should be kept in glass, steel or ceramic container which does not react with lactic acid present in it.

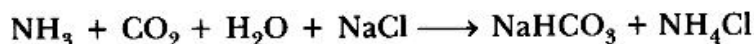

or

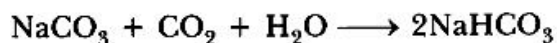

It is used as an antacid.

51. **Compounds like alcohols and glucose also contain hydrogen but are not categorised as acids. Discuss an activity to prove it.**

Answer. Take a beaker of 250 ml and place two nails fixed with the help of cork.

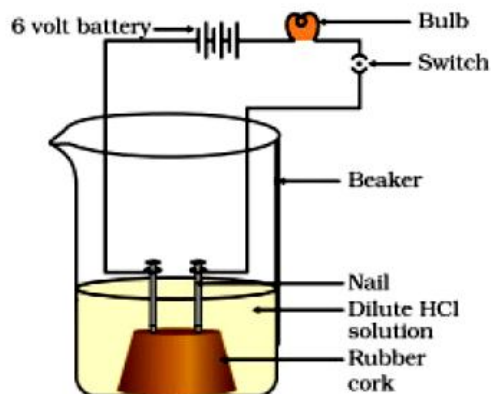

- Connect the nails to the two terminals of a 6 volt battery as shown in figure.
- Now add some water containing ethanol and put the switch ON.
- Repeat the experiment with glucose solution.

Observation : K The bulb will not glow and the needle of ammeter will not show deflection because glucose and ethanol do not conduct electricity.

Conclusion: The experiment shows glucose and ethanol do not ionise in aqueous solution, that is, they do not give H^+ ions, therefore cannot conduct electricity. Thus, glucose and ethanol are not categorised as acids.

52. **What is meant by ‘water of crystallisation’ of a substance ? Describe an activity to show that blue copper sulphate crystals contain water of crystallisation.**

Answer. The water molecules associated with a crystalline substance is called ‘water of crystallisation’.

To show crystalline salts contain water of crystallisation.

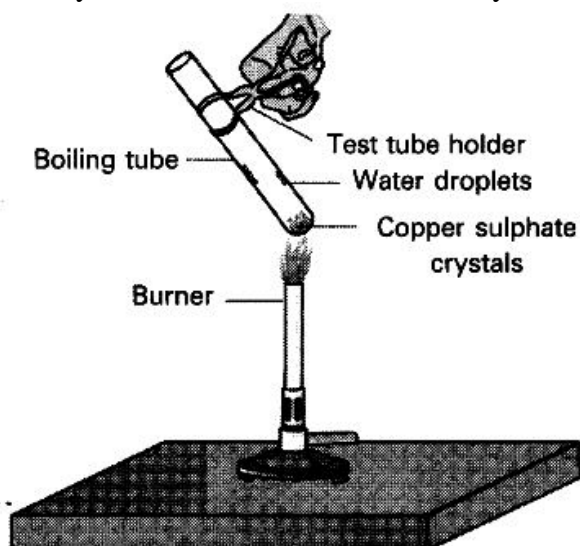

Materials Required: $\text{CuSO}_4 \cdot 5\text{H}_2\text{O}$ (Blue vitriol), boiling tube, burner, cork, delivery tube, test tube, clamp stand.

Procedure:

1. Take 2g of $\text{CuSO}_4 \cdot 5\text{H}_2\text{O}$ in a boiling tube fitted in a clamp stand.
2. Observe its colour. Fit it with cork and delivery tube bent at two right angles which dips into a test tube.

3. Heat crystals in boiling tube. ‘
4. Observe vapours being condensed in test tube.
5. Cool the crystals and add few drops of water into it.

Observation: Water vapours get condensed in a test tube and colour of blue crystals changes into white. On adding water to anhydrous copper sulphate, it changes into blue again.

Chemical Reaction:



Blue vitriol

White

Blue vitriol White

Conclusion: Crystalline substances have water of crystallisation which are lost on heating.

53. Name the products formed in each case when

- (a) hydrochloric acid reacts with caustic soda.
- (b) granulated zinc reacts with caustic soda.
- (c) carbon dioxide is passed into lime water.

Answer.

(a) Sodium chloride and water are formed.

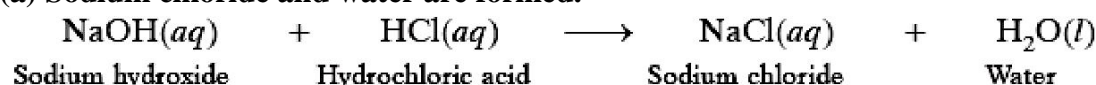

(b) Sodium zincate and H₂(g) are formed.

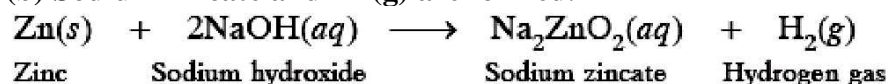

(c) Calcium carbonate and water are formed.

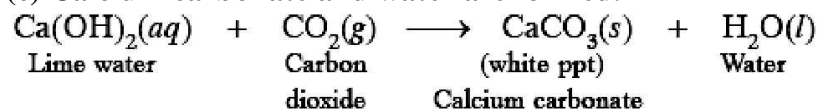

A white powder is added while baking breads and cakes to make them soft and fluffy. Write the name of the powder. Name its main ingredients. Explain the function of each ingredient. Write the chemical reaction taking place when the powder is heated during baking.

Answer. Baking powder.

It consist of sodium hydrogen carbonate and tartaric acid.

Sodium hydrogen carbonate gives CO₂ which makes cake soft and fluffy. Tartaric acid neutralizes the bitterness due to sodium carbonate produced.

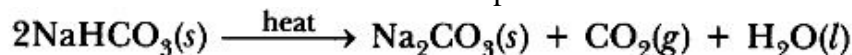

54. (a) What is an alkali? Give an example.

(b) Why do HCl, HNO₃, etc. show acidic characters in aqueous solutions while solutions of compounds like alcohol and glucose do not show acidic character?

Answer.

(a) Soluble bases are called alkalies, e.g. sodium hydroxide is an alkali.

(b) HCl, HNO₃ ionise in aqueous solution, whereas alcohol and glucose do not show acidic characters because they do not ionise in aqueous solution.